

## 6.2.8 Entrance Plan

The ground floor provides a highly active frontage to the north and east side of Plot 2, opening on to the adjacent public spaces. The Store is a visual focal point within the development and a commercial attraction for the wider community.

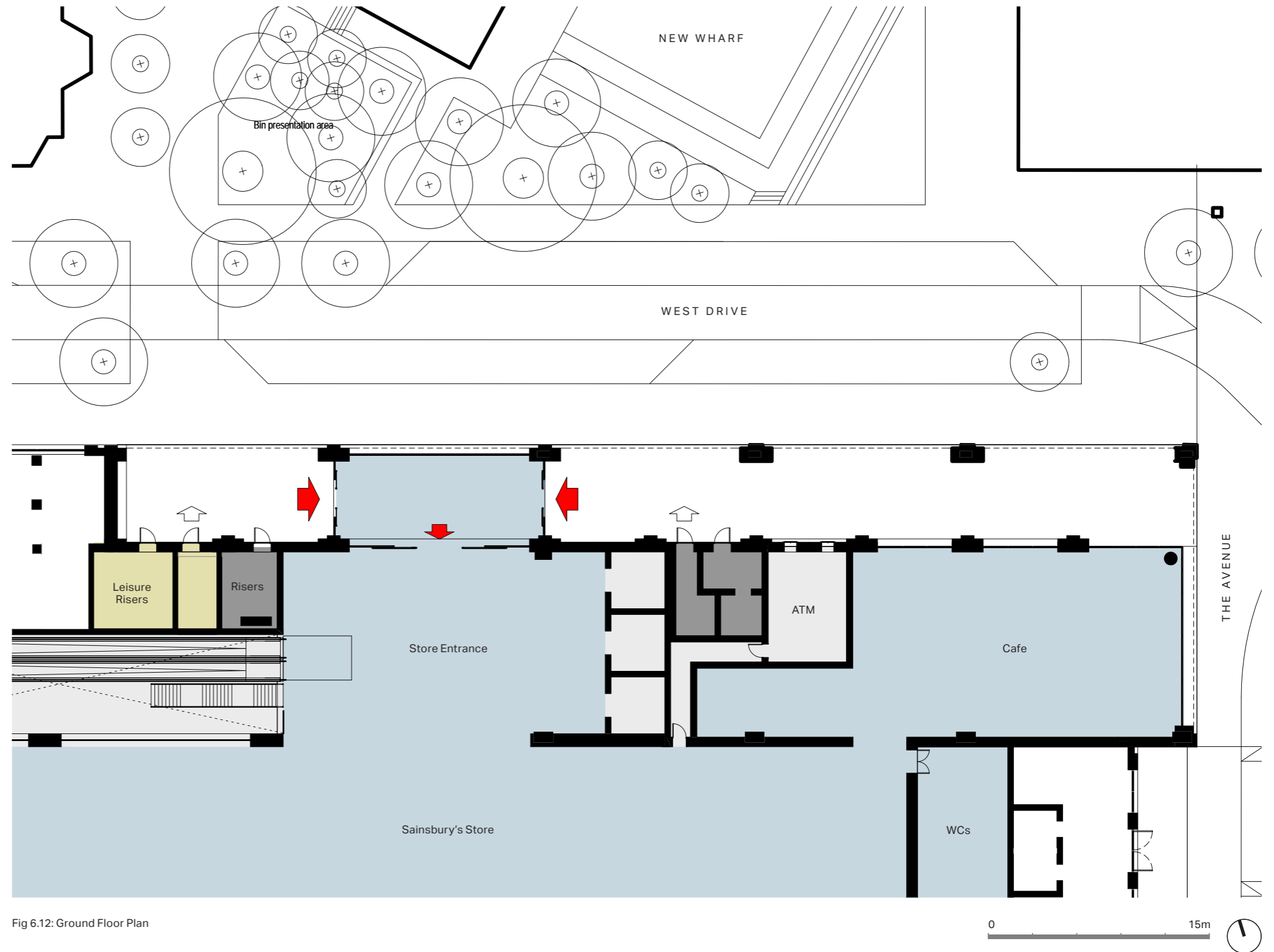

Fig 6.12: Ground Floor Plan

## 6.2.9 Section

The long section illustrates the relationship of the colonnade to the Store entrance and proposed variations in spaces in Building 2.6 above. The section illustrates the generous floor to floor height of the Store with the colonnade extending the full length of the building. This aims to extend the active frontage and covered route to the Store entrance, providing sheltered space for short-stay cycle provisions and ATMs.

Within the Outline element, Building 2.6 above the Store entrance is made up of Leisure space at Level 1 (Podium) and dual aspect residential accommodation above, with opportunity for more unique volumes to the top floor units under the pitched roof. The location of the Leisure space at Podium level will have direct level access for the public from street level, whilst also elevating the residential use away from the Store entrance, improving privacy as well as the quality of daylight and sunlight.

The section also illustrates the depth of the floor zones within the building above the Store, required to accommodate the services required to the residential buildings.

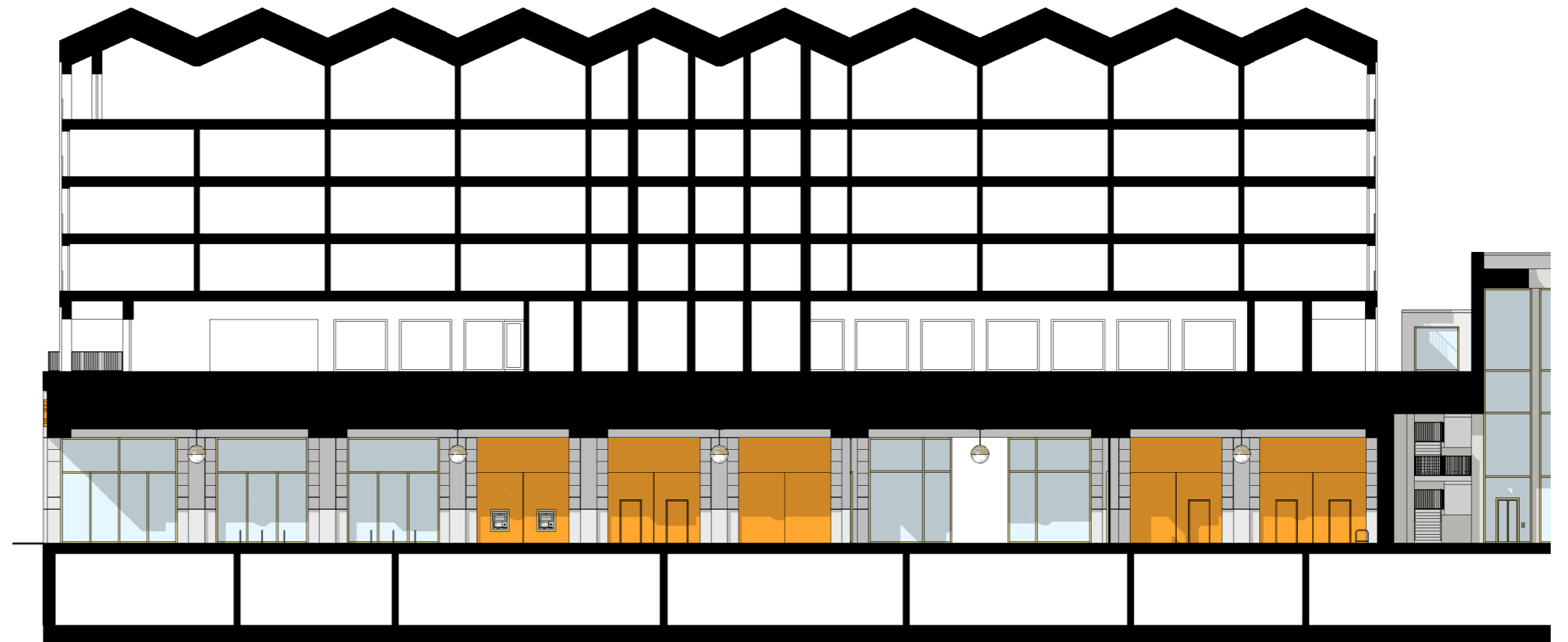

Fig 6.13: Store Entrance Section

0 15m



## 6.2.10 Elevations

The drawings below illustrate the development of the narrative and the application of materials to the north elevation, addressing the New Wharf on West Drive, and to the east elevation addressing The Avenue. This represents the detailed proposals for the Store included in the Detailed element, and the illustrative scheme for Building 2.6 above included in the Outline element. The architectural detailing has been developed together, ensuring that the scale and order of the overall composition is clearly defined, as well as the duality between the two components of the building.



Fig 6.14: East Elevation (Illustrative Scheme above Store)



Fig 6.15: North Elevation (Illustrative Scheme above Store)



## 6.2.11 Scale & Appearance

The image on the right illustrates the approach to the Store from Ladbroke Grove with the end elevation defining the end point of this public space. The double height colonnade is of a grandeur and scale befitting of its role as the entrance into the Store.

The colonnade also offers a layering of public space that, when combined with the landscaping, creates a spatial threshold between the public space of the canal basin and commercial space of the Store.

The use of curtain walling provides a link between the commercial frontage to the colonnade and the adjacent public spaces.

Extent of Detailed Element - -

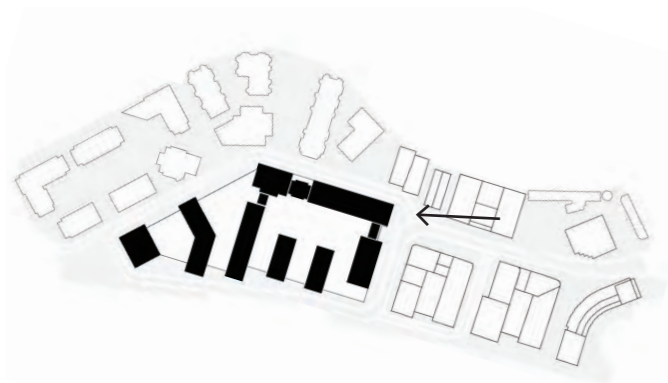

Fig 6.16: Proposed View of the Store Entrance - The Avenue (Outline element shown in white)



The form of the Store entrance and Building 2.6 is unified by the setting out the bays of the base in relation to the bays of the upper levels; the bays of the base are set out for every two bays on the level above. This grand scale of the base is further articulated and broken down to macro scale by the choice of white glazed faience cladding.

The contrast in material sets this building apart from the rest of Plot 2 and the neighbouring Plots, highlighting its importance and focal position in the development, and subtly referencing the glazed tile Victorian shopfronts.

Extent of Detailed Element - -

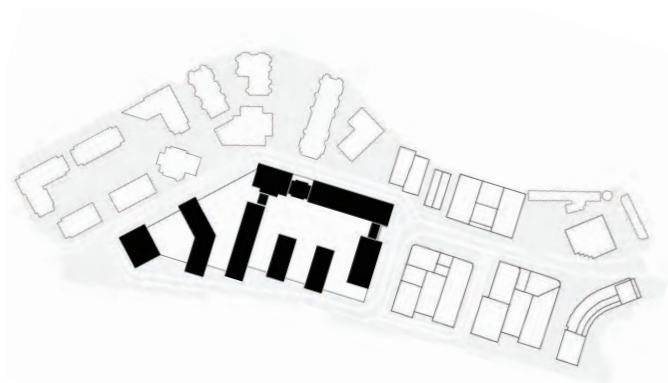

Fig 6.17: Proposed View of the Store - New Wharf, West Drive (Outline element shown in white)







## 6.2.12 Store, South Drive

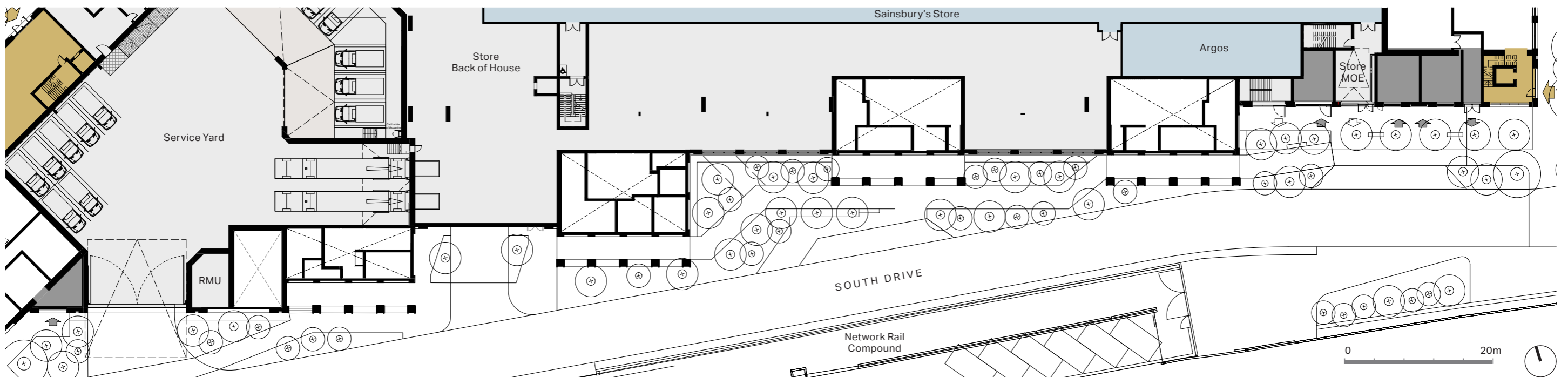

Fig 6.18: Elevation and Ground Floor Plan

The South Drive contains a series of Podium Buildings, comprised of the Store Back of House as well as the Store Service Yard entrance and the Car Park entrance for both residents and Sainsbury's customers. The site level drops due to the existing topography and provides access to the Car Park entrance located below the Store. The Podium Building ranges from two to three storeys high. Where

three storeys are achieved, the height is minimised by having a setback top floor with landscaping in order to maintain a more human scale along the South Drive. This area of the Podium Buildings also consists of a rhythm of pillars spanning the length of the elevation. A datum is read across the full elevation, wrapping the building into one whole unit, and emphasizing the monolithic nature of the architecture.

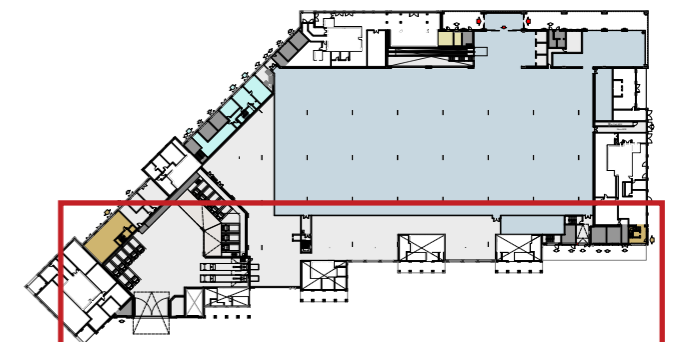





Fig 6.19: View of landscaping route along South Drive between Building 2.7 & Building 2.8



Fig 6.20: View of landscaped route along South Drive towards Building 2.2

The South Drive is interspersed with soft landscaped areas and deep recesses to the Service Yard and Car Park entrances, providing variation and a sense of protection to the facade. The material of this section of the Podium Building references the brown brick colour used on West Drive, again defining the spaces between the more dominant residential buildings in the Outline element. Although typically the back of

house of supermarkets are kept secluded and out of view, we were keen to focus on the employee's wellbeing allowing light to enter the workspace and further connect the Store to the community through visibility.





Fig 6.21: View of landscaped route along South Drive from Building 2.2 Colonnade



Fig 6.22: View of landscaped route between Building 2.2 & Building 2.3



# 6.3 Podium Buildings

## 6.3.1 Overview

The Podium Buildings on Plot 2 are a key aspect of the scheme as they knit together the whole design into a single form. The provision of commercial space and community space have been reviewed and developed as part of the diverse range of uses and activities throughout the masterplan, bringing vibrancy and vitality to the area.

The Detailed Elements of the podium buildings make up the lower two - three storeys of Plot 02 but exclude the residential cores, which are to be submitted in Outline and are explored in Section 7 of this report. The plan on the following page shows this subdivision of the Outline and Detailed elements and floor plans for Plot 02 are provided within the application to provide additional information.

Alongside the Sainsbury's Store already explored, the Detailed Elements of the podium buildings are comprised of two commercial spaces alongside various ancillary functions. These ancillary spaces include Residential Estate Management, Sainsbury's Back of House areas, Substations and Refuse Store access.

The use of architectural form and detailing cohesively complement the rest of the scheme whilst bringing further street activation. The following pages outline the use and architectural approach taken to these buildings and spaces, through a series of diagrams, plans and images.





### 6.3.2 Podium Buildings Layout

As well as the new Sainsbury's Store, the lower levels of Plot 2 accommodate commercial space, residential ancillary space, and leisure ancillary space as illustrated on this page. The combination of these spaces with Store form the podium of Plot 2, and infill the spaces in between the residential buildings proposed in the Outline element of the application.

There are three key podium buildings outlined in further detail in this chapter. These are the Residential Estate Management building located on West Drive, a commercial building also located on West Drive, and a second commercial building located on the corner of The Avenue and South Drive. These spaces have each been designed to form a distinct building in the streetscape, breaking down the massing into a series of identifiable buildings.

The residential and leisure ancillary spaces located at street level have been kept to an absolute minimum, with essential access provided to ensure compliance with building regulations. These spaces include fire-fighting access, means of escape, substations, and access to Refuse Stores. Where level access is not essential, ancillary spaces are located within the Basement levels.

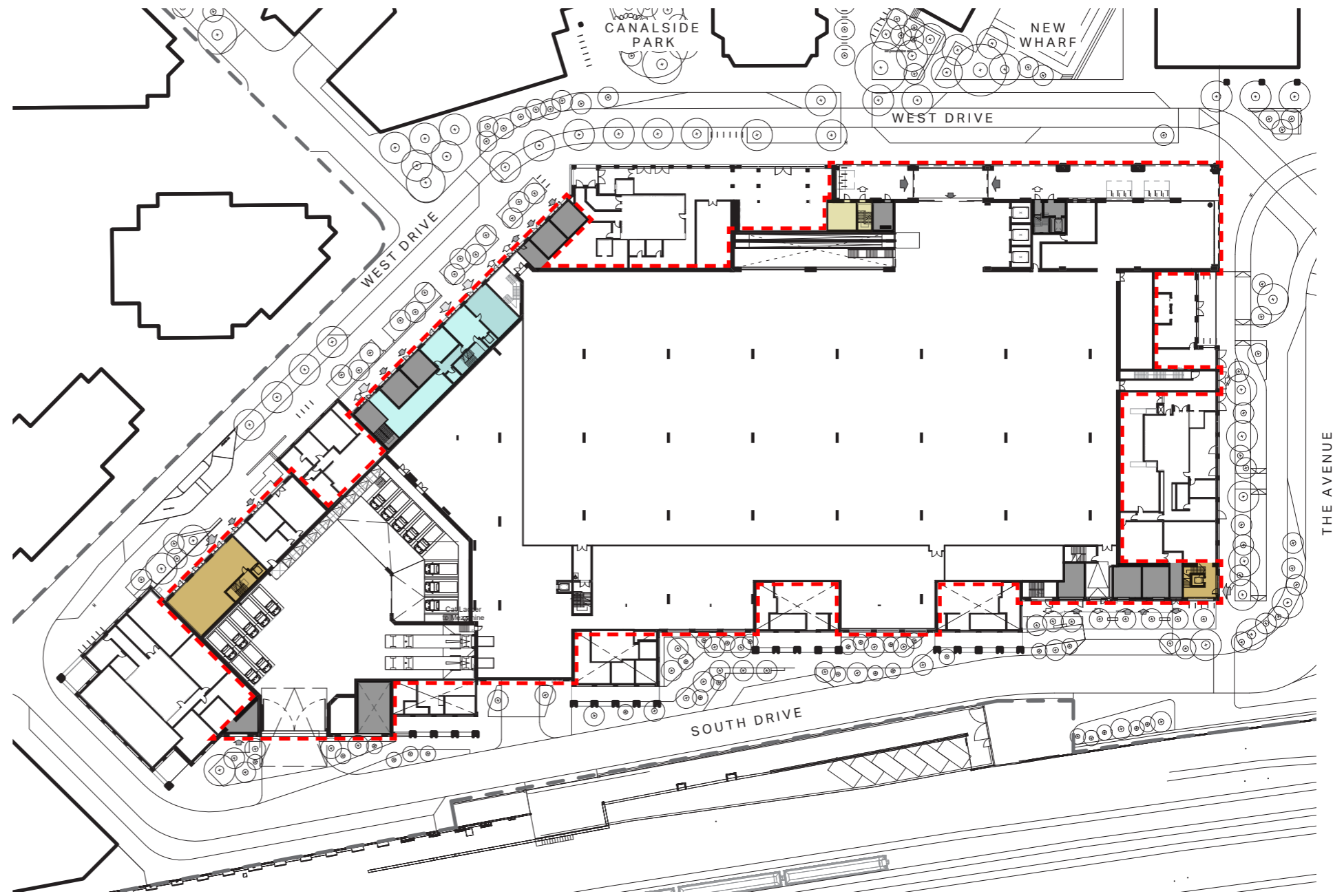

Fig 6.23: Ground Floor Plan: Podium Buildings (1:1000 @A3)

- - - Extent of Detailed Element
- Commercial Use
- Residential Estate Management
- Residential Plant, Substations, Means of Escape
- Leisure Plant, Means of Escape



### 6.3.3 Residential Estate Management

The Residential Estate Management is located on the West Drive, between Building 2.3 and Building 2.5, and is to be used by the Client to manage the Project Flourish development. The building is strategically positioned adjacent to Building 2.5 and the proposed Community Lobby identified in the Outline element of the proposals, where the majority of residents will access their homes.

The two storey building accommodates key residential ancillary spaces such as the CCTV Room, Fire Control Room, IT Room, and Substations. The building will have amenities such as a Parcel Room and Duty Manager's office accessed by residents, as well as a Canteen, Staff Room, Meeting Rooms and ancillary spaces for the management team.

The building also accommodates essential escape routes from the Store and Store Car Park.



Fig 6.24: Elevation and Ground Floor Plan

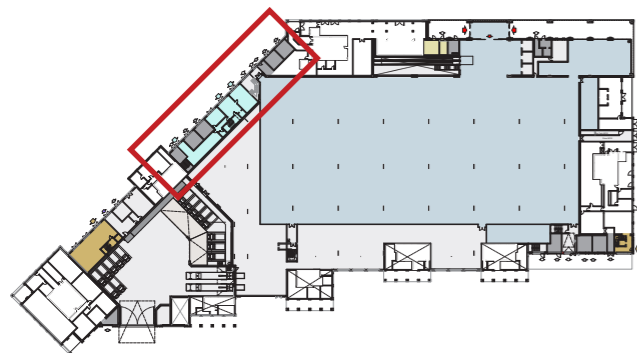





Fig 6.25: View of Residential Estate Management Elevation (Outline element shown in white)

The proposal, like most of the Podium Buildings, is to use a brown tone of brick, selected to contrast with the off-white and London stock bricks identified for the adjacent residential buildings in the Outline element. Together, the selection of brick tones form a neutral colour family whilst still distinguishing each

building individually within the streetscape. The architecture references the bay setting out in the illustrative scheme for the residential blocks, with the use of brick reveals to add interest and depth to the facade. A brass-coloured canopy is used to signify the public entrance of the building and provide shelter

from the weather. A grid of recessed brick panels combined with a light concrete continuous sill and cornice to the top creates a simple but composed facade. These brick bays are then crowned with the pergola structure on the podium garden above, establishing a connection between the street and the

landscaping.



### 6.3.4 Commercial Space, West Drive

There are two commercial buildings proposed within Plot 2. The first is located on West Drive, between Building 2.3 and Building 2.4. The proposed two-storey building will accommodate commercial space at both street level and on the first floor.

The building also accommodates ancillary spaces for the Store, including Service Yard Extract, Substation and a Fulfilment Room to service the Click & Collect facility, with dedicated parking bays in front of this building.

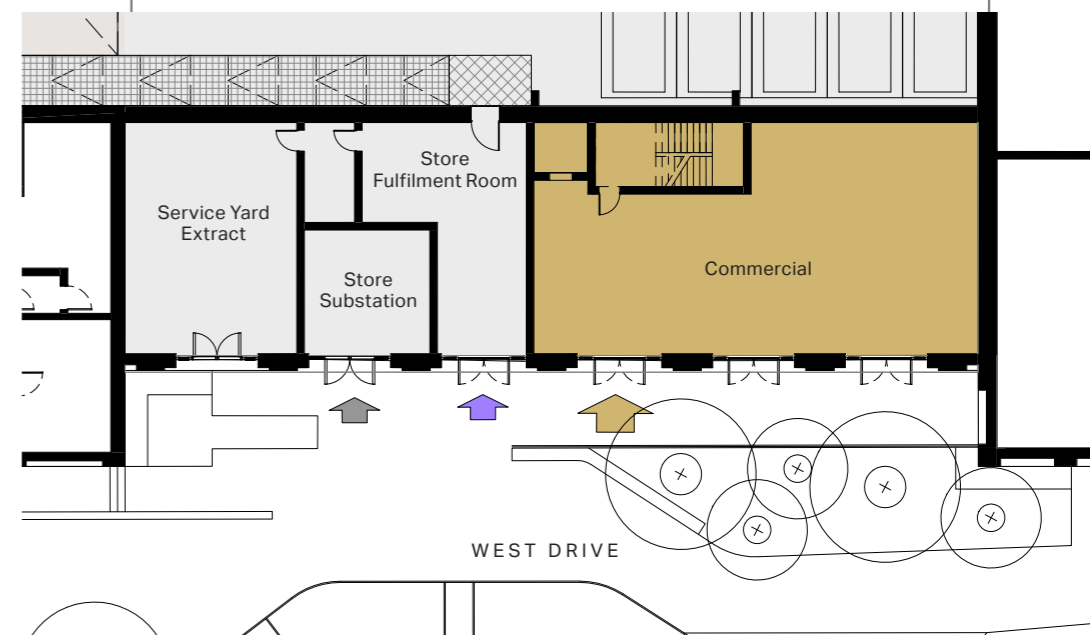
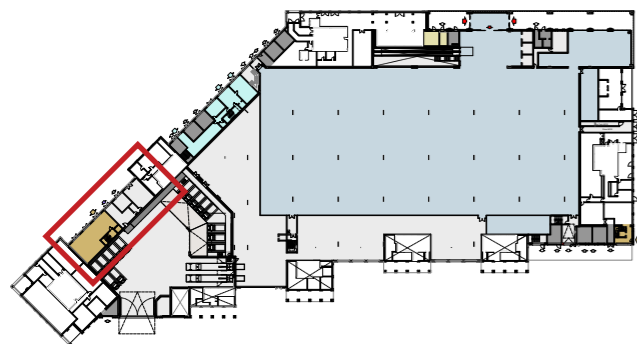

Fig 6.26: Elevation and Ground Floor Plan

0 15m







Fig 6.27: View of Approach to Commercial Space, West Drive (Outline element shown in white)

The commercial building is setback from the building line established by Building 2.3 and Building 2.4 to provide more space to enhance the public realm. Similar to the Residential Estate Management Building, the West Drive commercial building displays a very cohesive facade. Set back from the

neighbouring residential buildings, the elevation is formed of a rhythm of pillars and brick reveals. The lighter continuous sill and cornice detailing to the top of the building, connects through to the adjacent buildings composing the plot as a whole. A brass-coloured canopy is also used, creating an association



Fig 6.28: View of Commercial Space Elevation, West Drive (Outline element shown in white)

with the Residential Estate Management Building and suggests a different use to the residential buildings. The same pergola structure is used on the podium garden to crown the building, establishing a connection between the street and the landscaping above.



### 6.3.5 Commercial Space, The Avenue & South Drive

The second commercial building is located on the corner of The Avenue and South Drive, south of Building 2.1. The proposed two-storey building will accommodate commercial space on both floors.

Located on the south-east corner of Plot 2, this space will activate a key corner and intersection within the masterplan and potential future bridge connection to the south.

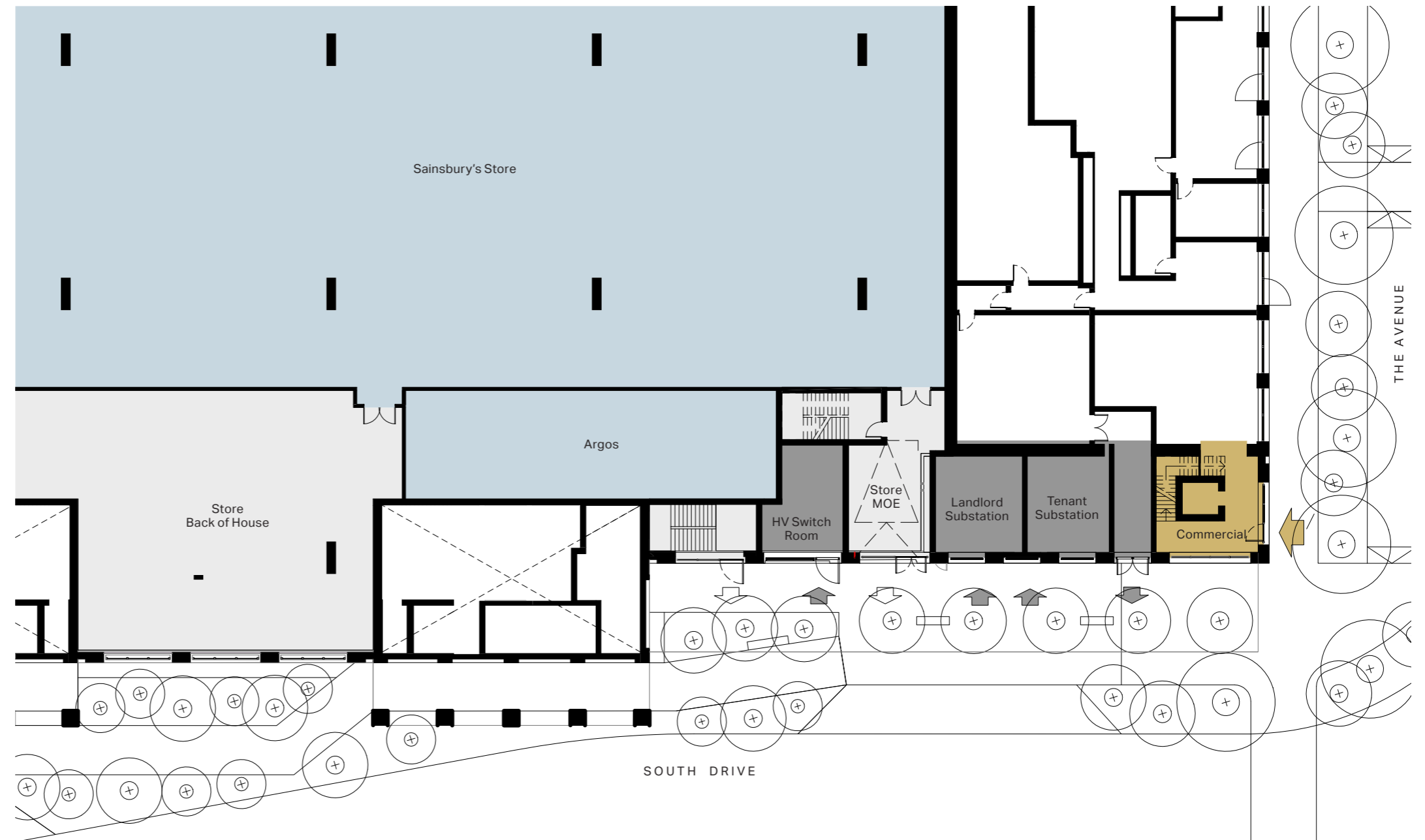

Fig 6.29: Ground Floor Plan

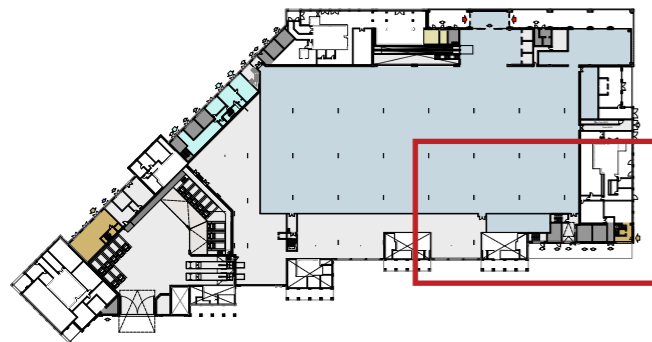





Fig 6.30: View of Commercial Space, on the corner of The Avenue and South Drive (Outline element shown in white)

The lighter brick tone for this section of the Podium Building are taken from the adjacent block, Building 2.1. A reduced grid has been generated in comparison to the rest of the Podium Buildings in order to reflect the elevational grid illustrated for Building 2.1 in the Outline element, whilst more generous openings wrap

the corner of the building, to form the entrance. Brass coloured panels and mullions bring warmth to the elevations and a contrasting tactile feature.

This page is intentionally blank





# 7.0 Illustrative Proposals - Plot 2

<b>7.1</b>	<b>Residential Buildings</b>	<b>184</b>	<b>7.3</b>	<b>Building 2.9 : Sports Pavilion</b>	<b>202</b>
7.1.1	Composition	184	7.3.1	Introduction	202
7.1.2	Residential Layout - Basement Plan	185	7.3.2	Look & Feel - Interior	203
7.1.3	Residential Layout - Ground Floor Plan	186	7.3.3	Look & Feel - Facade	204
7.1.4	Residential Layout - Typical Floor Plan	187	7.3.4	Approach	205
7.1.5	Materials & Detailing	188	7.3.5	Scale & Massing	206
7.1.6	Design Intent - Regency	189	7.3.6	Scale & Massing	207
7.1.7	Design Intent - Grand Union Canal	190	7.3.7	Proposed Layout	208
7.1.8	Design Intent - Gasworks	191	7.3.8	Sports Court	210
<b>7.2</b>	<b>Technical Considerations</b>	<b>193</b>	7.3.9	Screening Room	211
7.2.1	Accessibility	193			
7.2.2	Fire	194			
7.2.3	Security	195			
7.2.4	Vehicular Parking	196			
7.2.5	Cycle Parking	197			
7.2.6	Sustainability	200			







**Alongside the new Sainsbury's Store, Plot 02 is comprised of a range of residential apartments of varying tenure types, unifying the plot with the quieter, western edge of the masterplan.**

Drawing inspiration from the regency style, canalside industrialisation and the gasworks heritage, the residential buildings across Plot 02 are deeply embedded in both the site and wider borough's history.

# 7.1 Residential Buildings

## 7.1.1 Composition

The eight residential buildings form the Outline element of the proposals on Plot 2. The overall scale and massing of these buildings has evolved in response to the key considerations discussed throughout the planning process, aiming to provide high quality spaces throughout the masterplan.

The tallest building, B2.1, acts as the marker building within the wider context. Located in the centre of the masterplan the building also acts as a visual marker for the new supermarket location.

The mid-height buildings, B2.4 and B2.5, aim to open up and respond to the adjacent public spaces, whilst the linear buildings above the store have been located to the south of the plot in a north-south orientation to maximise daylight and sunlight.

Building 2.6 is unique in its scale and orientation due to its important relationship to the wider masterplan as outlined on the previous page. Deck access along the north elevation provides activation and depth to the north facade whilst accommodating dual aspect homes.

The Outline element also includes the provision of the Community Lobby on West Drive. The lobby provides a shared vertical connection to the residential buildings on the Podium level as well as Concierge and Post Rooms. A separate dedicated entrance is also provided for the Leisure use located at Podium level of Building 2.6. The entrance frontage is located between Building 2.1 and Building 2.6 on The Avenue, providing public access to the leisure facilities.

The following pages illustrate the extent of the Outline elements at each level and the architectural approach used to develop the illustrative scheme.

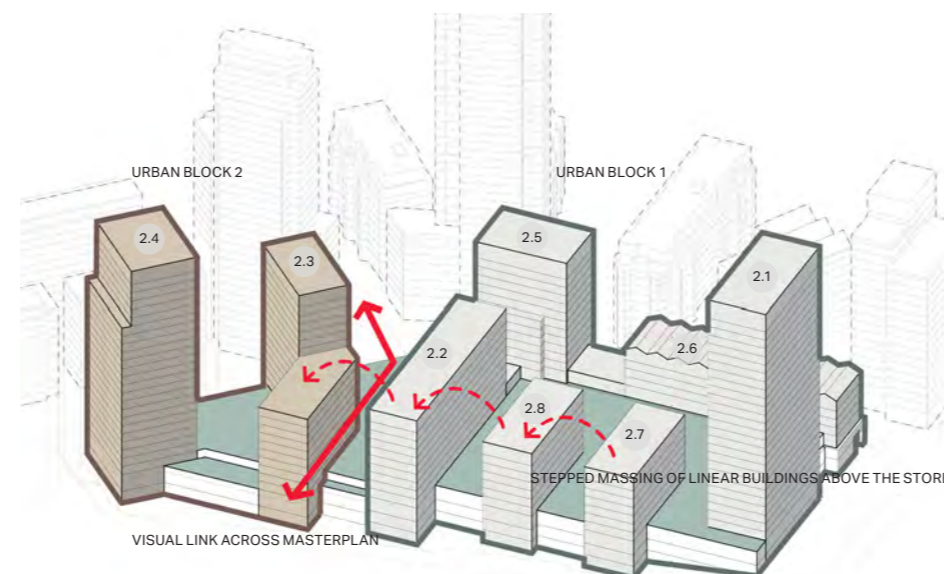

Fig 7.1: Massing concept diagram taken from South East

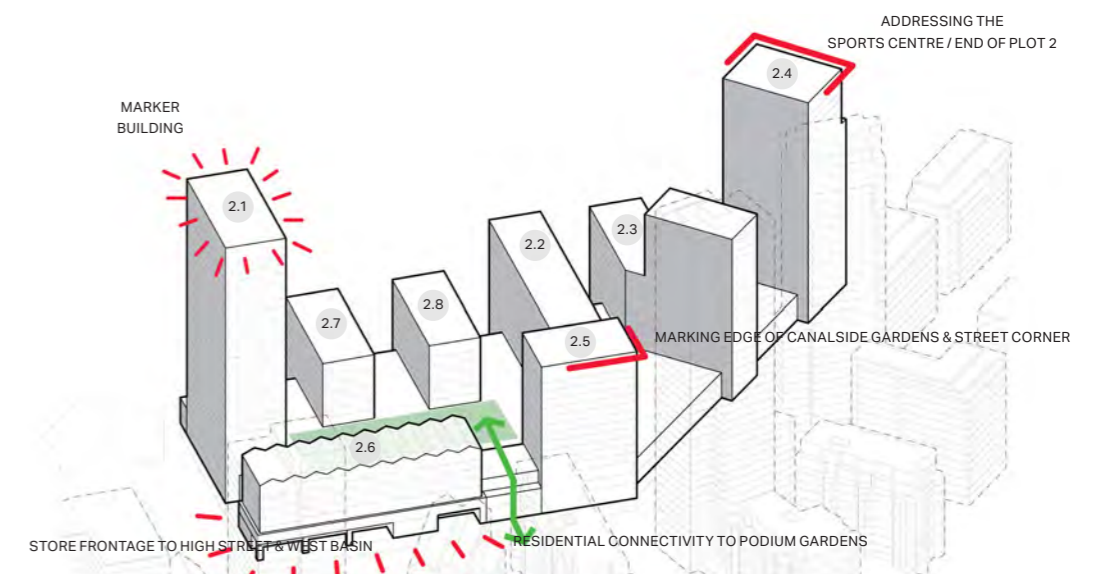

Fig 7.2: Massing concept diagram taken from North East



### 7.1.2 Residential Layout - Basement Plan

The majority of the Basement is included in the Detailed element of the scheme, with the exception of the residential entrances that address South Drive.

Each core illustrated provides access to a residential building. A double height colonnade to each building aims to clearly identify the entrance, activating the South Drive as well as providing shelter.

The cores also accommodate two means of escape from each building, fire-fighting access, and Refuse Store access to the street.

Additional ancillary space, including Cycle Stores, Substations and Plantrooms, are located in the basements within the Detailed element of the application.

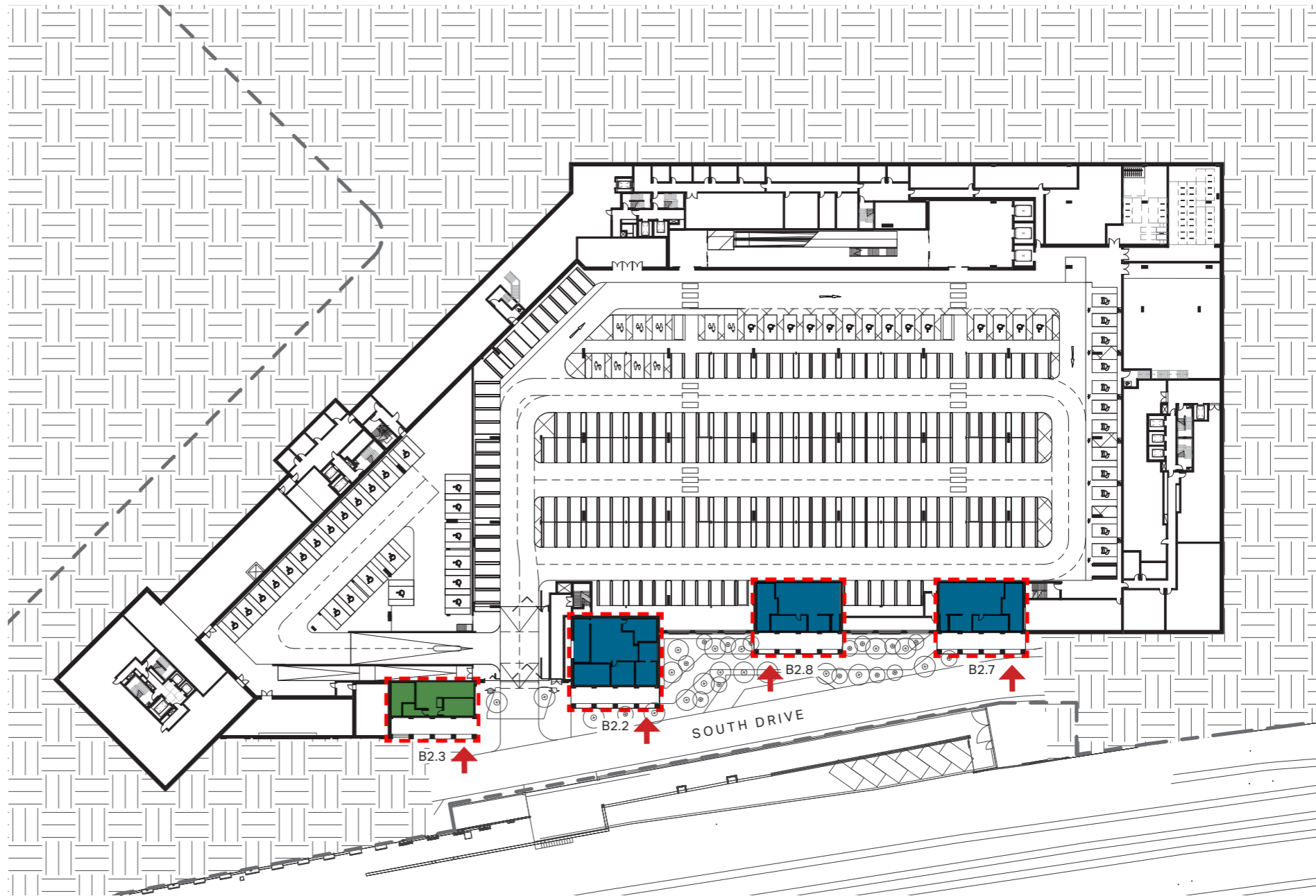

Fig 7.3: Basement Plan: Outline Element (1:1000 @A3)



- - - Extent of Outline Element
- Private Tenure Units / Core & Ancillary
- Intermediate Tenure Units / Core & Ancillary
- Affordable Rent Tenure Units / Core & Ancillary
- ➔ Residential Entrance

### 7.1.3 Residential Layout - Ground Floor Plan

Similar to the residential entrances identified at Basement level, the remainder of the residential entrances are located to the perimeter of Plot 2 at Ground Floor level on The Avenue and West Drive.

Similarly, each core illustrated provides access to a residential building. Larger floor to floor heights and the use of projecting canopies are proposed in order to clearly identify the entrances and provide shelter, as well as activating the street frontages.

Each core accommodates two means of escape from each building, fire-fighting access, Refuse Store access to the street. Dedicated entrances for cyclists are also provided to access Cycle Stores at Ground and Basement levels.

Additional ancillary space, including Cycle Stores, Substations and Plantrooms, are located in the basements within the Detailed element of the application.

In addition to the individual residential entrances, a Community Lobby is proposed as a shared residential entrance. Accessed at Ground Floor level on West Drive opposite Canalside Park, as illustrated on the plan, this provides vertical connectivity to the podium gardens, as well as shared facilities such as Concierge and Post Rooms for the Private Tenure buildings.

The entrance to the Leisure use is also identified on the plan, provided dedicated access to the facilities on Podium level.

The remainder of the commercial space is provided at ground floor level in Building 2.1. This is an extension to the commercial space included in the Detailed element of the scheme.

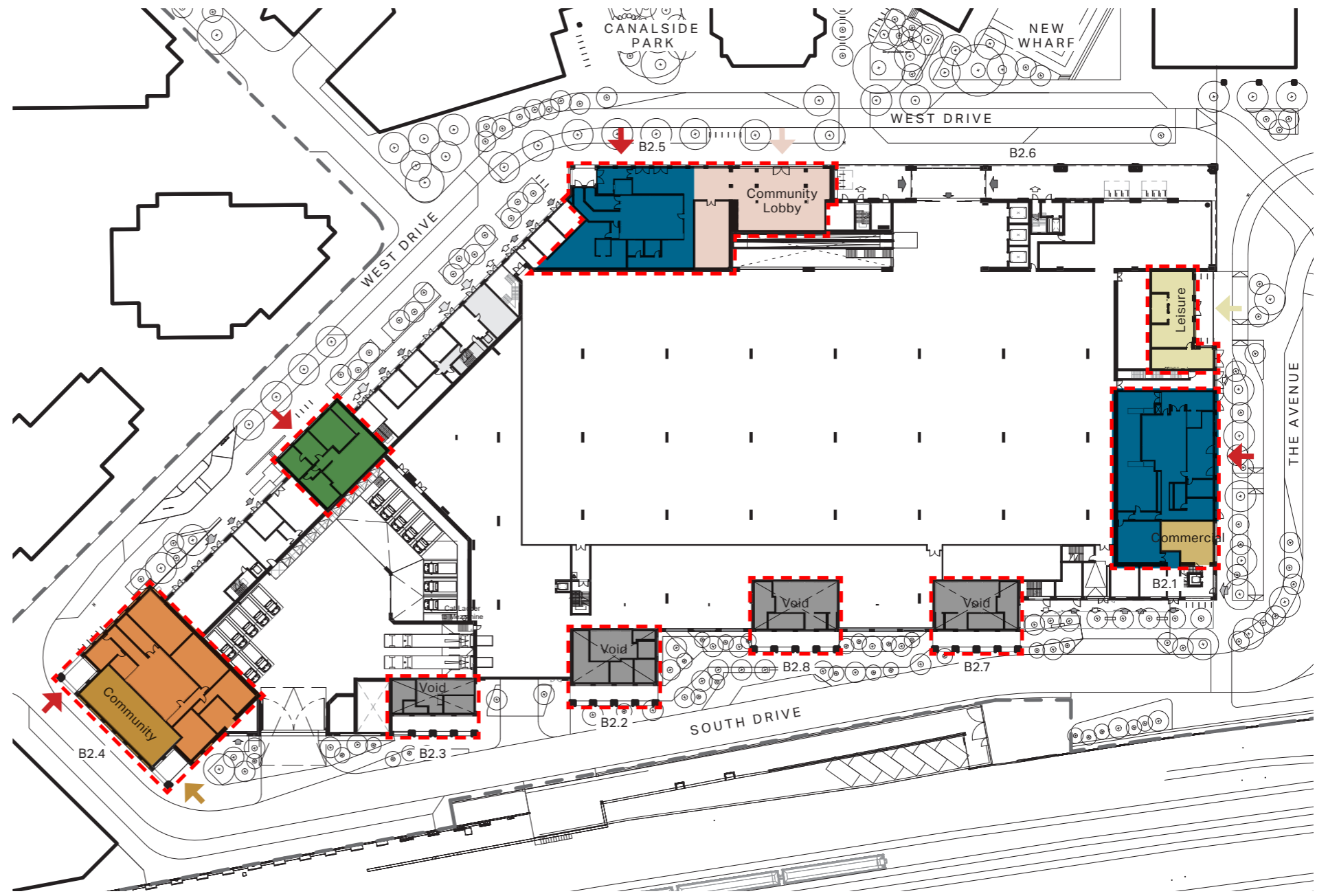

Fig 7.4: Ground Floor Plan: Outline Element (1:1000 @A3)

- - Extent of Outline Element
- Private Tenure Units / Core & Ancillary
- Intermediate Tenure Units / Core & Ancillary
- Affordable Rent Tenure Units / Core & Ancillary
- ➔ Residential Entrance
- Residential Community Lobby
- ➔ Residential Community Lobby Entrance
- Leisure Use
- ➔ Leisure Use Entrance
- Commercial Use
- Community Use
- ➔ Community Use Entrance

### 7.1.4 Residential Layout - Typical Floor Plan

The typical floor illustrates the general arrangement of residential units on Plot 2 developed as for the illustrative scheme.

The eight buildings are arranged around three interconnecting podium gardens, providing shared external amenity space for residents, as well as balconies providing private external amenity to each unit.

The buildings are typically arranged in a north south orientation with a minimum of 18m between buildings in order to maximise the quality of natural light and to avoid north facing units.

The orientation of Building 2.6 differs, arranged in an east west orientation in the centre of the masterplan. Deck access along the north facade enables each unit to have dual aspect, north and south.

The Outline element of Plot 2 consists of a mix of residential (Class C3), leisure (Class E), and community (Class F1/F2) uses. Plot 2 consists of c. 947 high quality apartments. The range of units has been designed to include a mix of studios, one, two, three and four bed units. 10% of the units provided will be wheelchair adaptable homes (M4(3) standard).

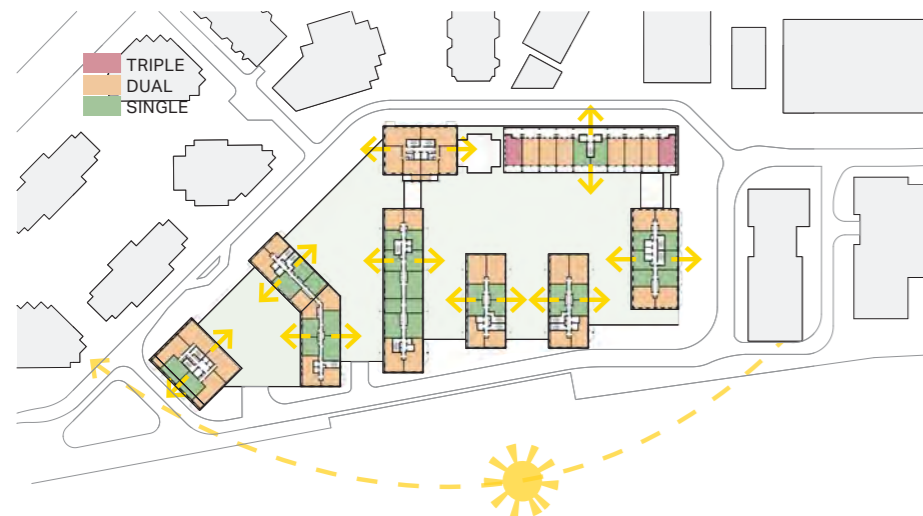

Fig 7.6: Aspect & Outlook

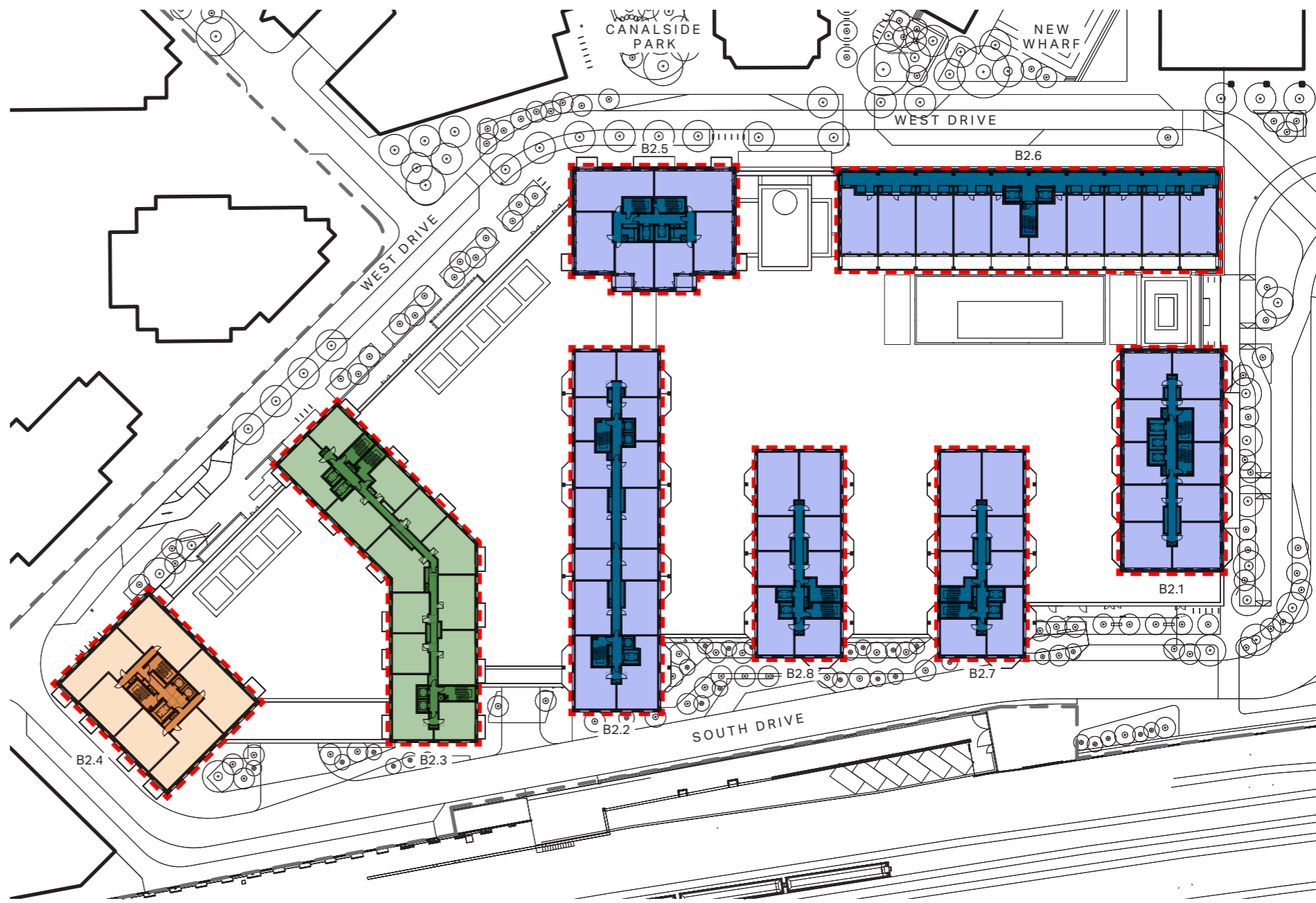

Fig 7.5: Typical Floor Plan: Outline Element (1:1000 @A3)

- - - Extent of Outline Element
- Private Tenure Units / Core & Ancillary
- Intermediate Tenure Units / Core & Ancillary
- Affordable Rent Tenure Units / Core & Ancillary
- ➔ Residential Entrance





## 7.1.5 Materials & Detailing

The materiality and detailing of each residential building has been developed to inform the illustrative scheme, and to understand the relationship between the residential buildings in the Outline element and the Detailed element of the scheme.

To further articulate and break down the massing proposed within Plot 2, the proposed composition of the facades varies, as outlined in this chapter. Whilst each urban block draws from the wider context of the site, variations to the window proportions, materiality, and balcony detailing aim to provide a defined character.

A distinct treatment and materiality should be employed to strategic locations within the masterplan whereby the architectural expression will generate moments of visual interest or intensity within the scheme, or act as a marker signifying a route or entrance. This approach has been applied to Plots 2.1 and 2.6 on Plot 2, as outlined in the following pages.

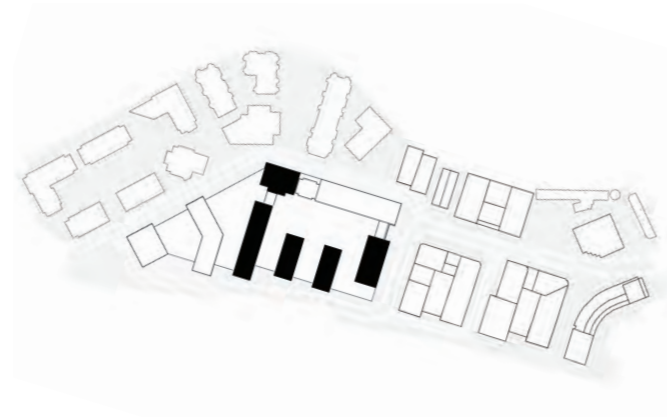

Urban Block 1 - Regency Style



Fig 7.7: Plot 2.1, 2.2, 2.5, 2.7, 2.8 - Indicative Materials

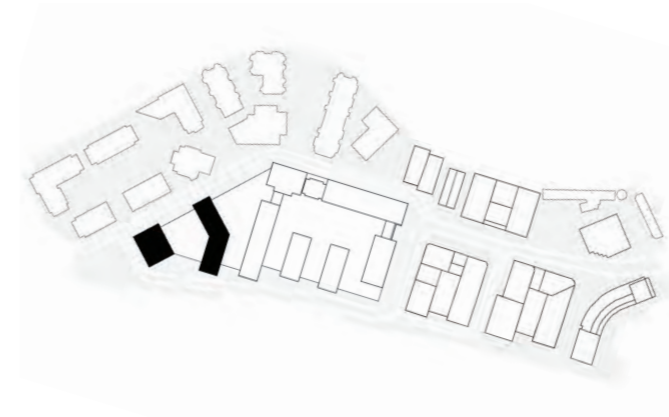

Urban Block 2 - Canalside Industrialisation



Fig 7.8: Plot 2.3, 2.4 - Indicative Materials

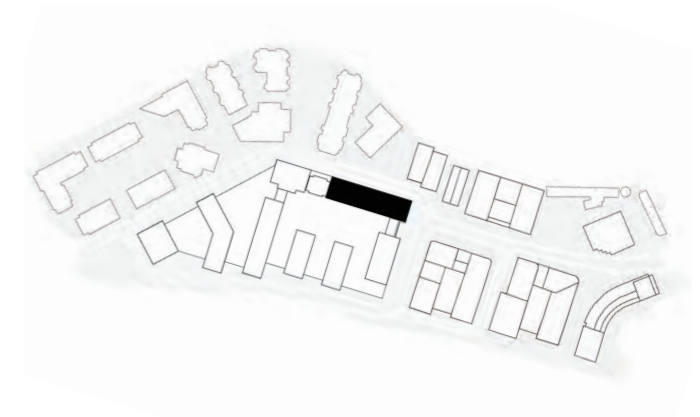

Gasworks Heritage



Fig 7.9: Plot 2.6 - Indicative Materials

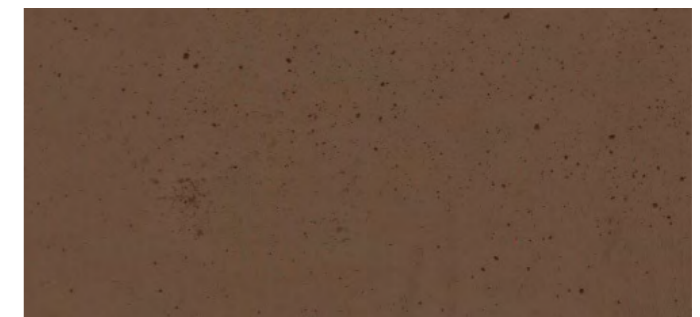
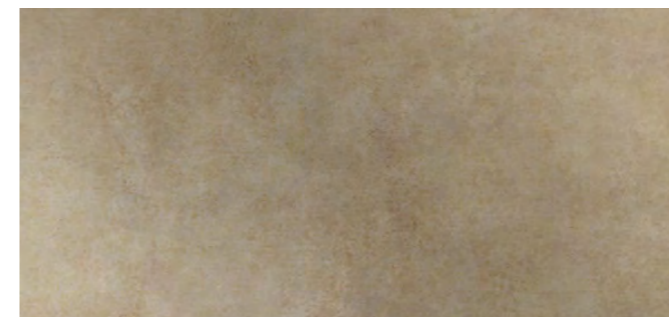



### 7.1.6 Design Intent - Regency

Drawing on the Regency style, the aim is to develop a contemporary architecture in response to the classical context of Ladbroke Grove. The use of robust materials such as brick and precast concrete in lighter tones with a simplicity of form and full height window openings, balanced with elegant detailing of metalwork aim to unify a collection of the buildings within Plot 2 to form the first urban block.

The definition of order; base, middle, and top to the more vertical buildings, and the rhythm and use of faceted projecting bays on the linear buildings aims to respond to the timeless qualities of the classical architectural style.



Fig 7.10: Facade Components Precedents



Key Plan - Regency Style



1  
BASE



2  
BODY



3  
CROWN



## 7.1.7 Design Intent - Grand Union Canal

The use of light buff brickwork, the buildings have more solidity with punctured window openings with raised sills, and restrained detailing through the application of continuous cornices aims to respond to the architecture of the Grand Union Canal, forming the second urban block within Plot 2.

Rectangular projecting bays further defines the restrained approach. Similar to the architectural approach to the Regency style detailing, a limited palette of robust materials is proposed, and the use of precast concrete for the detailing provides continuity between the two urban blocks.



Fig 7.11: Facade Components Precedents



Key Plan - Grand Union Buildings



1

BASE



2

BODY



3

CROWN



### 7.1.8 Design Intent - Gasworks

The illustrative scheme suggests Building 2.6 on Plot 2 is where particular design attention should be given, designed to promote visual interest and coherence within the overall masterplan character.

The form and materiality have been informed by the industrial architecture of the former gasworks. Located above the store entrance and with publicly accessible leisure facilities provided at Podium Level, the building is located centrally within the masterplan. The use of a pitched-roof structure framing internal and external spaces, and clad in a darker bronze-coloured cladding, the aim is to celebrate the site's heritage. This approach enables the proposed building to be easily identified, contrasting with the neighbouring buildings.



Fig 7.12: View looking east towards Building 2.6, West Drive



Fig 7.13: View from a balcony of Building 2.5 looking across the podium gardens towards Building 2.6



Key Plan - Gasworks Heritage



Fig 7.14: Street level view of Community Lobby Between Building 2.5 and Building 2.6



Fig 7.15: Raised sectional perspective showing vertical circulation in Community Lobby







# 7.2 Technical Considerations

## 7.2.1 Accessibility

The proposals for the site are designed to be fully inclusive to all users regardless of their protected characteristics, and physical or mental ability. This includes consideration when designing the approach to the buildings, entrances, common circulation areas, and facilities throughout Plot 2. In preparing the design, a number of access standards and policies have been taken into consideration. These include but are not limited to:

- The Equality Act 2010
- The Building Regulations 2010: Approved Document M Access to and use of Buildings, Volumes 1 & 2
- BS 8300-1: 2018 Design of an accessible and inclusive built environment. External environment, Code of practice
- BS 8300-2: 2018 Design of an accessible and inclusive built environment. Buildings - Code of practice
- BS 9999: 2017 Fire safety in the design, management and use of buildings - Code of practice
- BS 9991: 2015 Fire safety in the design, management and use of residential buildings
- The London Plan: March 2021
- Housing Supplementary Planning Guidance, London Plan 2016 Implementation Framework: March 2016

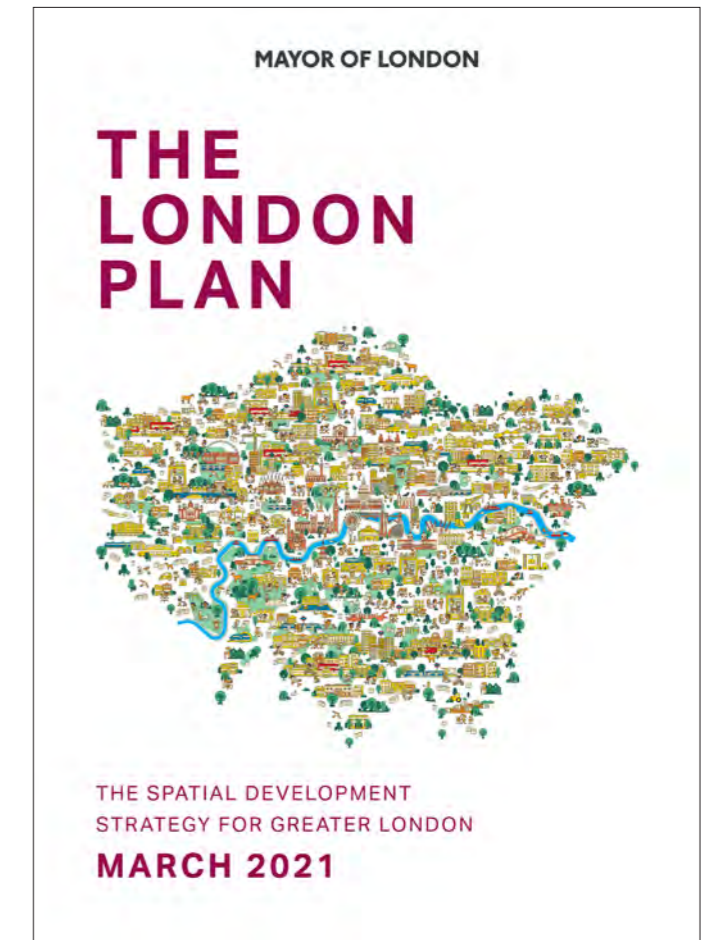
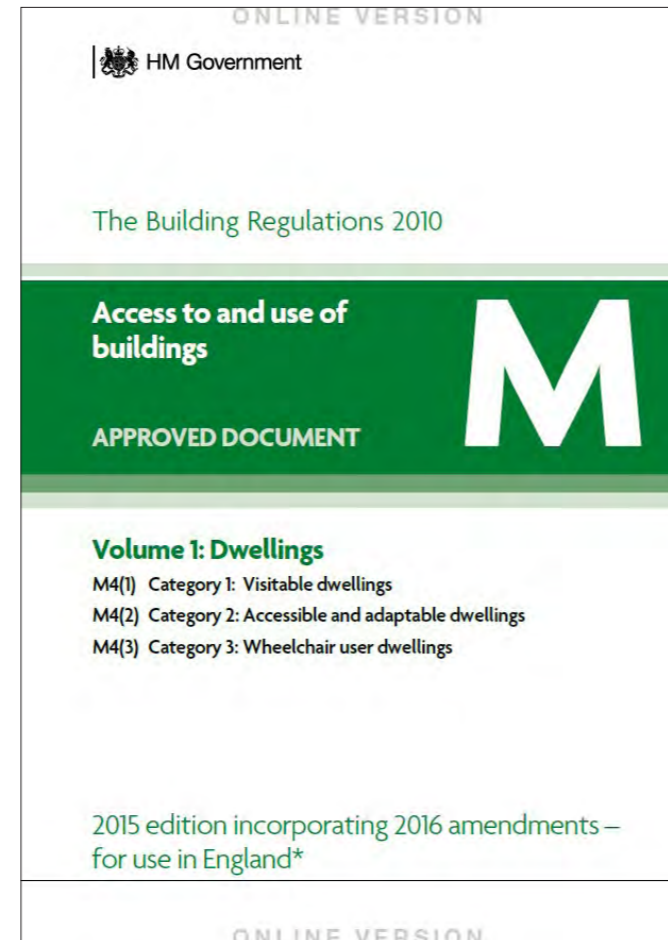

## 7.2.2 Fire

The Fire Strategy for Plot 2 has been produced by Hoare Lea in conjunction with the design team. Hoare Lea have also produced a London Plan Planning Statement, and Gateway One Planning Statement.

The fire strategy will address issues relating to means of escape, internal fire spread, external fire spread, and Fire Service access and is principally based upon the guidance given in BS 9991 and BS 9999, and are to be read in conjunction with the architectural drawings. Any recommendations within the reports are subject to discussion and approval by the Statutory Authorities. Full details can be found within these reports which accompany this application.

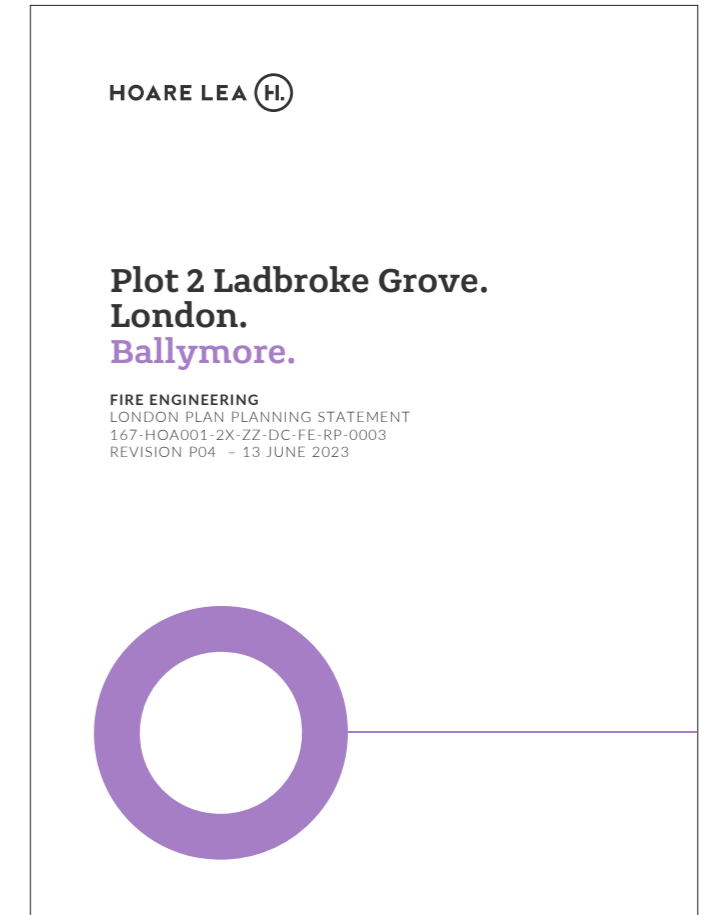
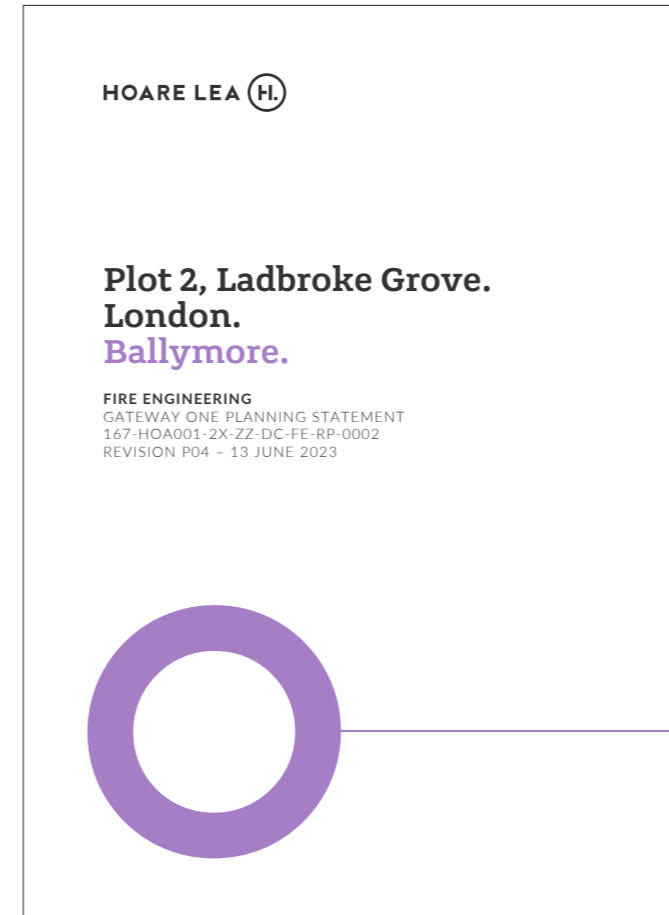

### 7.2.3 Security

The proposals have been designed from the outset to be a safe and secure new neighbourhood in the Royal Borough of Kensington & Chelsea. The scheme follows the principles described in Approved Document Part Q 2015, as well as Secured By Design. As part of the planning process the design team has met with Design Out Crime Officers and Counter Terrorism Officers from the Metropolitan Police. Below is a summary of the recommendations provided, which have been divided into three categories:

#### Recommendations integrated into the design from an early stage:

Clear sight lines and the removal/redesign of any 'hidden' alcoves.

No linkage between public, private and commercial areas.

Clear and defined cycle lanes, where possible separated from the pedestrian path. Appropriate mitigation to be considered for any anti-social riders.

Inclusive access along pavements (including the blind).

Mitigation to ensure that pavements do not become an unofficial highway for youths on mopeds as experienced with many other such paths in London.

Proposed lobbies at the residential entrances with the lifts & stairs behind a secondary access/egress door. This creates an air lock entry system to deter tailgating or unauthorised person.

Private ground floor terraces, as well as those facing the public podium space to have landscaping that provides a defensible space without hindering surveillance.

#### Recommendations integrated following review with Officers:

The Plot 2 residential parking was not fully separated from the Sainsbury's car parking. A full height gate with fob access control has been added, in order to prevent crime in these areas. The mechanism should be protected from tampering with armoured conduit. The exit buttons should be far enough away so that it can't be pushed with a stick from outside.

A pedestrian gate has also been introduced to allow cycle users and pedestrians to come and go without conflicting with vehicles.

#### Recommendations to be incorporated at the detailed design stage:

A lighting strategy is to be developed by a lighting engineer, seeking good uniformity (i.e., the difference between light and dark patches is reduced), no light pollution and no glare, whilst achieving a white illumination where possible as this gives the best colour rendition.

Any planting should not impede the opportunity for natural surveillance and avoid the creation of potential hiding places. Shrubs should be selected to have a mature growth height no higher than 1 metre, and trees should have no foliage, epicormic growth or lower branches below 2.4 metres thereby allowing a 1.4 metre clear field of vision.

Street furniture that is sustainable, robust and does not encourage anti-social behaviour, such as loitering, rough sleeping, skateboarding, etc.

Appropriate CCTV monitoring the area (linked with the lighting strategy). CCTV to link up with the RBKC control room.

Signage along the routes should have uniformity; it should not change size, shape, colour, enabling easier understanding for users.

Secondary communal doors are to be a minimum of PAS24:2016 security-rated, fob access controlled with audio / visual access linked to the individual residential units. They should be self-closing and self-locking.

Developments can suffer adversely from anti-social behaviour due to unrestricted access to all areas and floors of buildings. Therefore, to prevent free movement throughout the buildings the use of access control at each floor is to be developed.

Access from the basement car parking into the residential cores is to be through fob access controlled LPS1175 SR2 / A3, STS202 BR2/B3 or LPS 2081 security rated doors.

Lighting should be carefully co-ordinated, so that potential areas of risk are adequately covered. A good lighting scheme will help to deter intruders and reduce the fear of crime. CCTV can help deter crime and criminal behaviour and provide reassurance for residents and visitors. It can also provide key evidence of any criminal activity. Therefore a CCTV & lighting strategy around the building and communal areas, including entrances & exits, postal strategy, cycle and bin stores, all footpaths, communal and associated areas to main building.

Both the vehicular and pedestrian gates should be self-closing with an appropriate stay open time so to prevent unauthorised access into the basement parking areas.



## 7.2.4 Vehicular Parking

Plot 2 will provide parking for both the customers of the Store and the residential occupants in line with RBKC's Parking Standards 2015, the current London Plan standards, and the client brief.

The Store car park is located at basement level below the Store and is accessed from the South Drive. The same entrance will be used to access the residents' car park, which will be located below the Store Service Yard.

The Store Car Park provides 227 spaces including 14 accessible spaces, 9 Parent & Toddler spaces, and 12 active electric charging spaces., a significant reduction of 169 spaces compared to the existing car park.

The illustrative scheme for Plot 2 proposes 24 wheelchair accessible car parking spaces for residents.

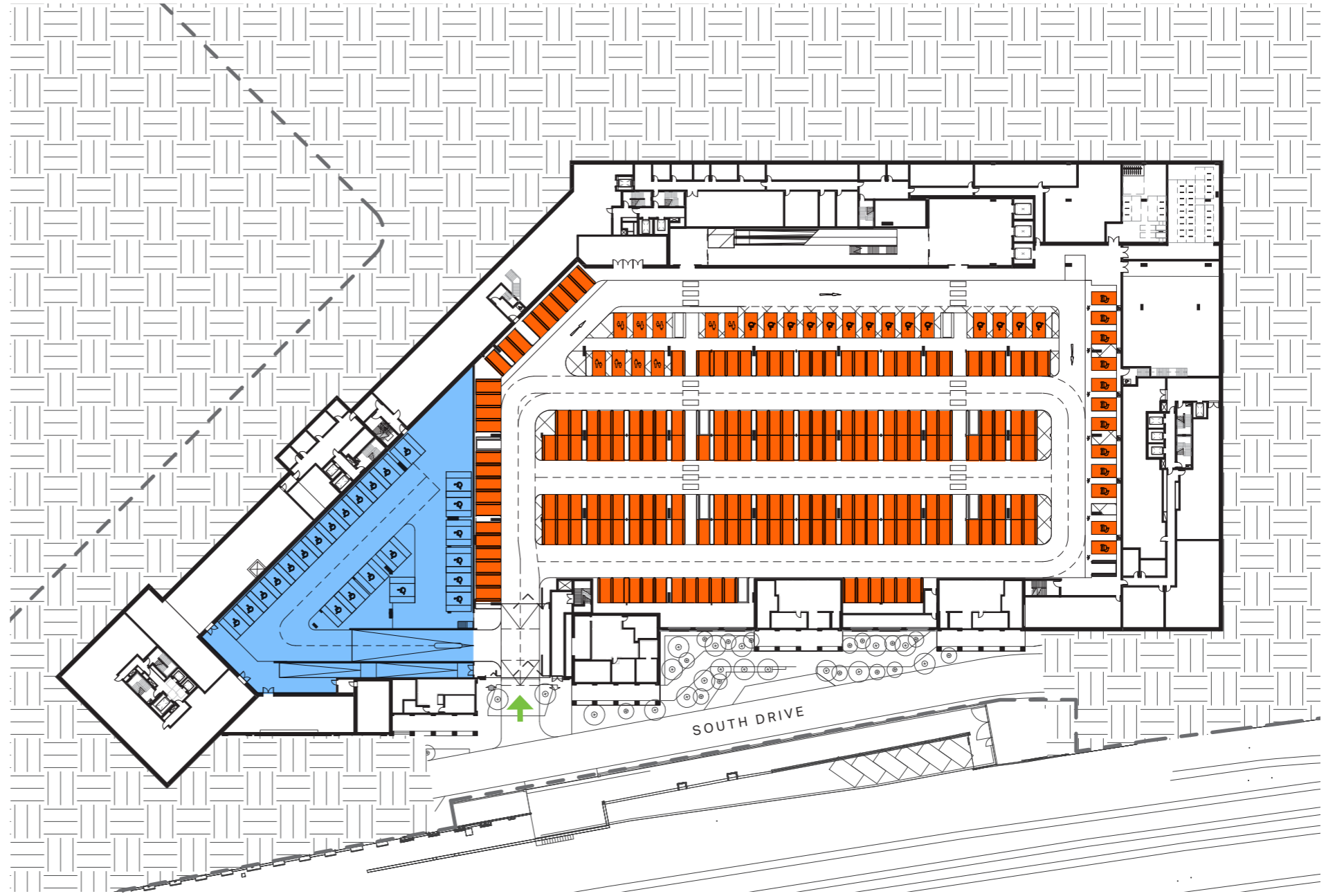

Fig 7.16: Basement Plan: Car Parking Provisions (1:1000 @A3)

### Sainsbury's Store Parking Provisions

Standard Spaces	192	(85%)
Active Charging Spaces	12	(5%)
Accessible Spaces	14	(6%)
Parent & Toddler Spaces	9	(4%)
Total	227	(100%)

- Residential Parking (Illustrative Scheme)
- Sainsbury's Customer Parking
- ← Car Park Entrance





### 7.2.5 Cycle Parking

Cycle provisions for Plot 2 have been assessed by the transport consultant, WSP, based on guidance published by TfL and the GLA.

Dedicated Cycle Stores are located at Basement level for Sainsbury's staff (32 Long Stay spaces) and customers (54 Short Stay spaces). The Cycle Stores are accessed via the Store Car Park. An additional 16 Short Stay spaces for customers will be provided at street level adjacent to the Store entrance.

Residential cycle spaces will be located in secure Cycle Stores for each building at basement and ground floor level. A number of Cycle Stores will be accessed from the Residents' Car Park via a dedicated cycle ramp. Cycle Lobbies with lift and stair access will also be provided where required.

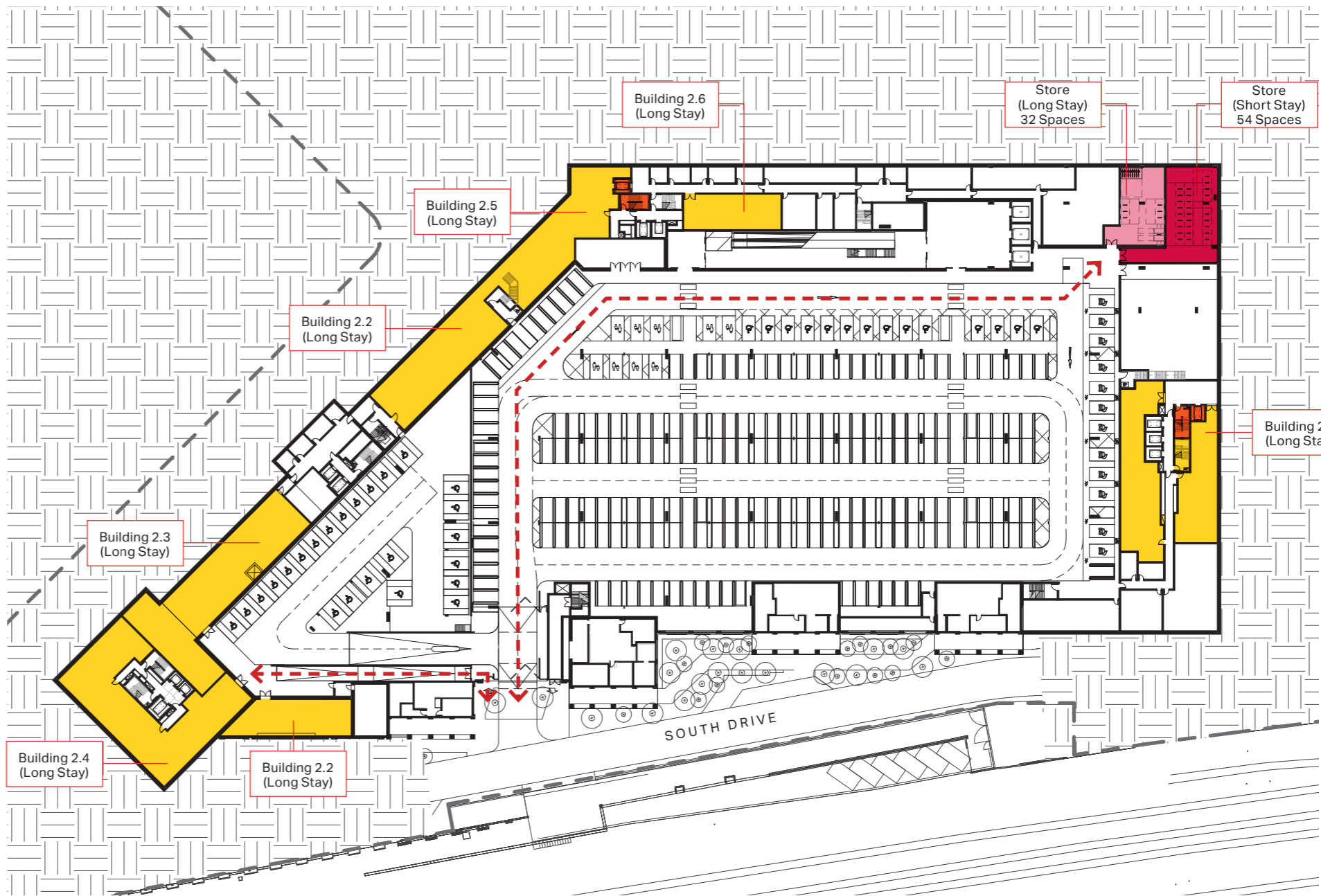

Fig 7.17: Basement Plan: Cycle Provisions (1:1000 @A3)

- Store Long Stay
- Store Short Stay
- Residential Long Stay
- Cycle Lifts & Stairs
- Level Access Cycle Routes



There is additional customer cycle provision (16 Short Stay spaces) located under the colonnade on West Drive in close proximity to the Store entrance. Further short stay spaces are located across Plot 2 where required, outside the commercial spaces, Community spaces, Leisure Use, and residential buildings as illustrated here.

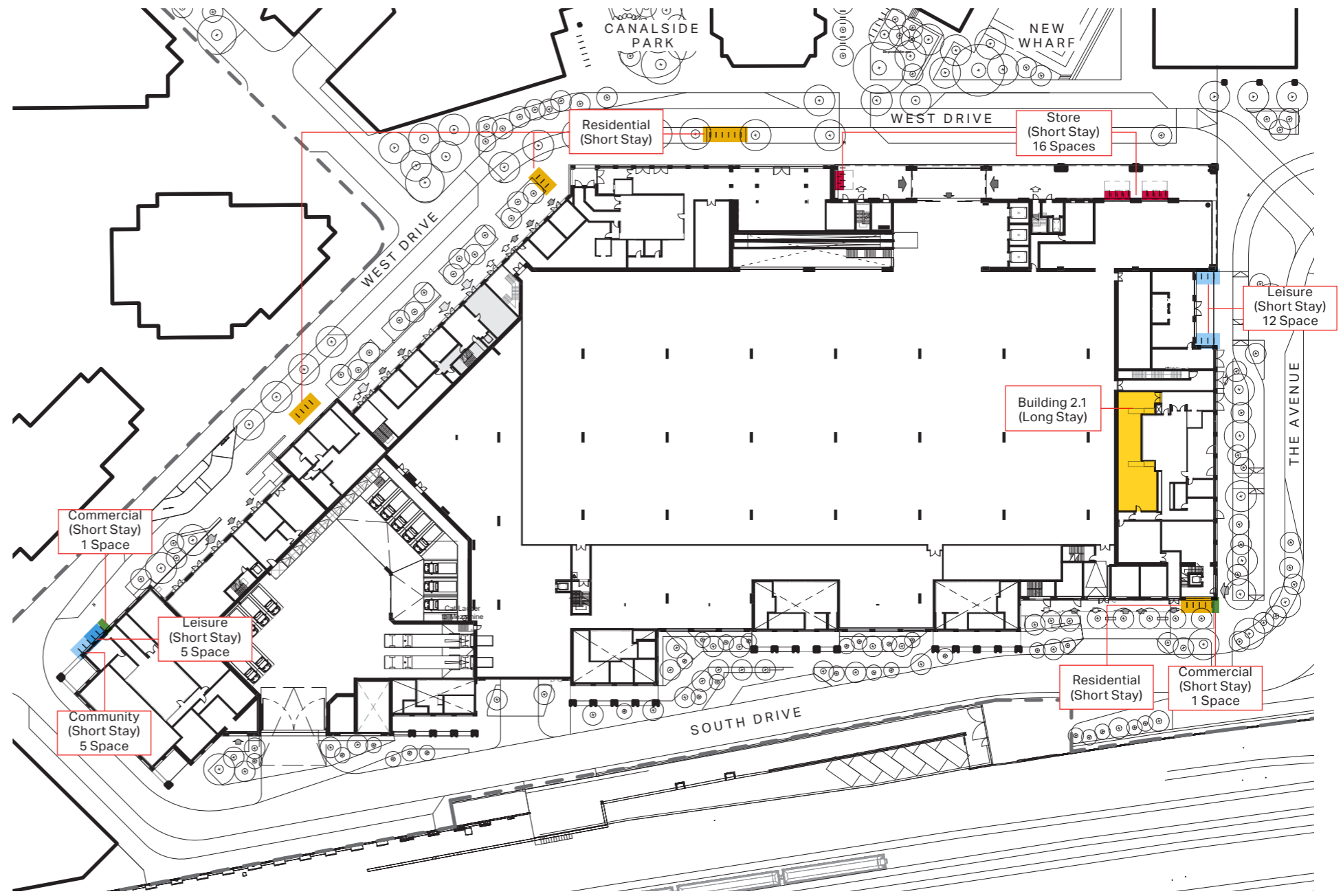

Fig 7.18: Ground Floor Plan: Cycle Provisions (1:1000 @A3)

- Residential Long Stay
- Residential Short Stay
- Store Short Stay
- Leisure Short Stay
- Community Short Stay
- Commercial Short Stay



This page is intentionally blank



## 7.2.6 Sustainability

The Sustainability Strategy has been produced by Hoare Lea in conjunction with the design team. Hoare Lea have produced a Sustainability Statement, Energy Strategy, as well as carrying out Thermal Comfort Assessments and preparing BREEAM Pre-Assessments for the relevant building uses within the proposals.

The strategy has been informed by national, regional, and local policies – including, NPPF, Building Regulations Part L, the Greater London Authority (GLA) London Plan (2021), the London supplementary planning guidance (SPG) on Sustainable Design and Construction (2014), and the current Royal Borough of Kensington and Chelsea Local Plan (2019), London Plan Guidance on Circular Economy and Whole Life Carbon.

The strategy is to be read in conjunction with the architectural drawings. Any recommendations within the reports are subject to discussion and approval by the Statutory Authorities. Full details can be found within these reports which accompany this application. The following page highlights the key design moves and technologies proposed on Plot 2.

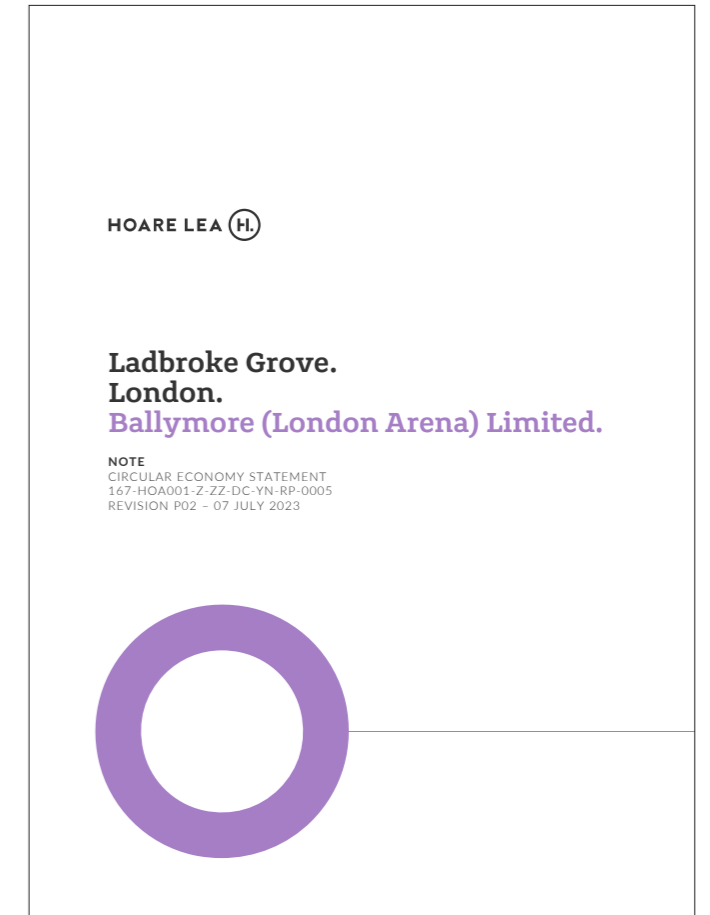
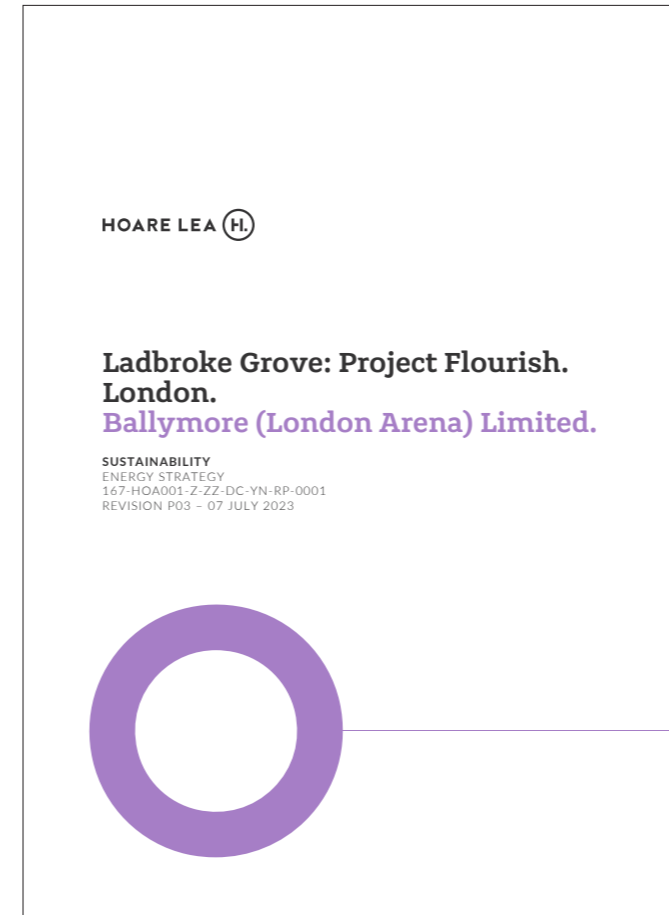
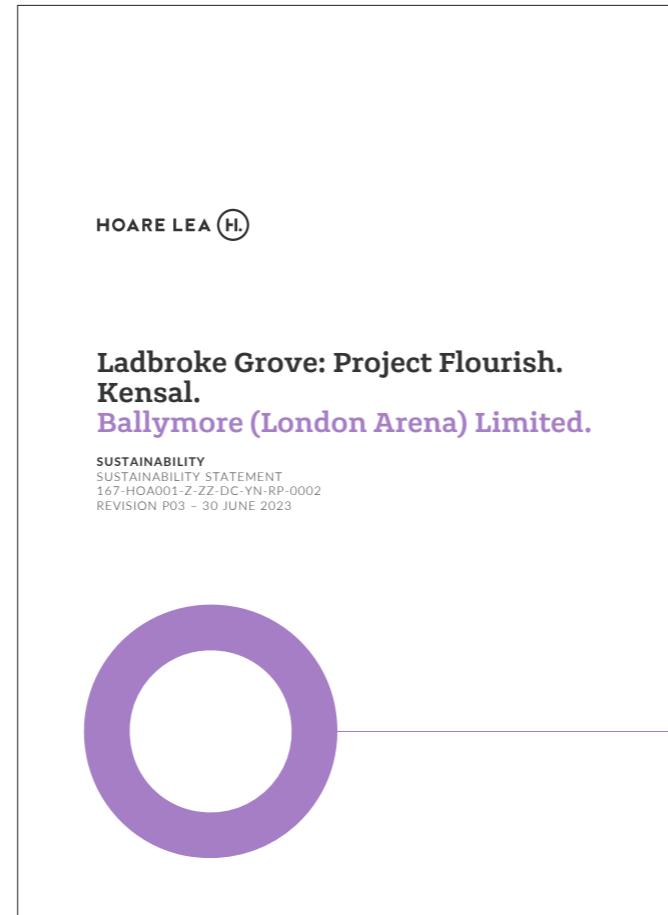







## 7.3 Building 2.9 : Sports Pavilion

### 7.3.1 Introduction

Building 2.9 has been designed in collaboration with the London Sports Trust to provide a community sports facility in the south western corner of the masterplan.

The facility has been designed to accommodate a range of functions and will complement the other sports pavilion building (Plot 6.2) located on the existing basin.

A set of plans, adjacent and overleaf, have been proposed to illustrate how the building could be laid out to accommodate the facilities required by the LST.



### 7.3.2 Look & Feel - Interior

The accompanying images serve as visual references, showcasing suitable materials and forms that would be fitting for Plot 2.9. The walls of the sports court should convey a lightness, with the upper section having a translucent appearance. This would allow privacy whilst also hinting at the functions within, when viewed from the outside.



Fig 7.19: Look & feel precedents



### 7.3.3 Look & Feel - Facade

The accompanying images serve as visual references, showcasing suitable materials and forms that would be fitting for Plot 2.9. The external appearance of the building should contain a robust plinth, given the hardwearing nature of the building. The upper levels could incorporate materials which are translucent, so that the building could act as a beacon in the evening. Suitable building precedents are shown adjacent. This approach would hint at the functions within whilst maintaining a level of privacy for users.

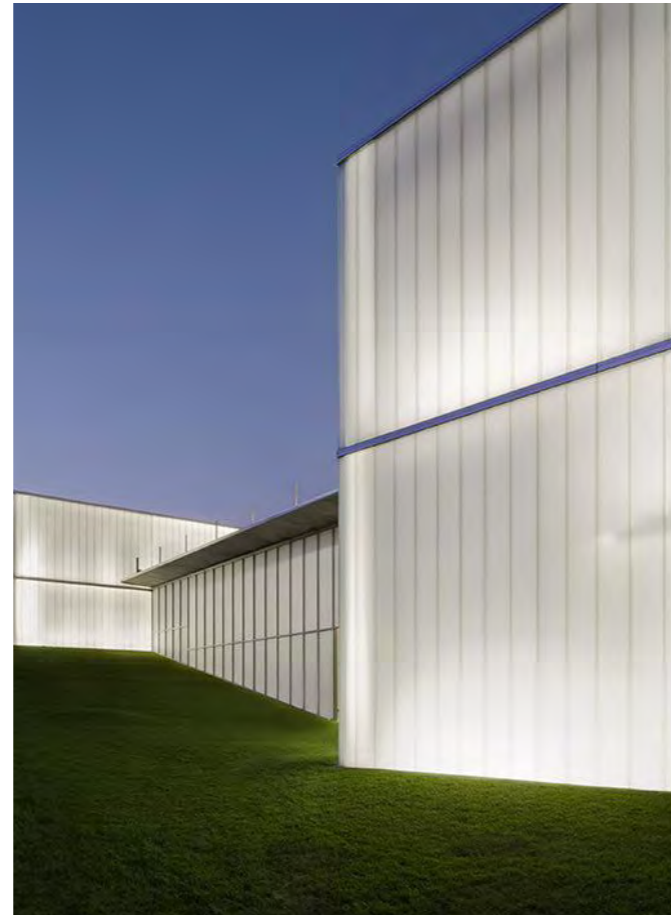

Fig 7.20: Look & feel precedents



### 7.3.4 Approach

The building can be approached from the east via South Drive, from the west via Plot 03 and from the north via West Drive. The main entrance is located adjacent the road edge and a community garden sits to the east of the plot, providing a calmer environment for the building users.

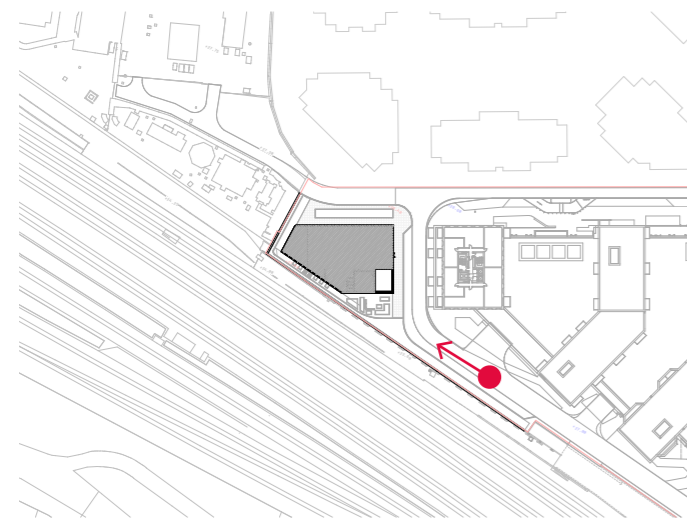

Fig 7.21: View location



Fig 7.22: Illustrative design proposal



### 7.3.5 Scale & Massing

The proposed design conveys an appropriate scale and massing for the building, whilst seeking to incorporate some of the key functional requirements of the LST to help articulate the design. The height of the building would be constrained to between 2 and 3 storeys, depending upon the final use of the building. This would also ensure it retains a 'pavilion' quality, and is recessive in scale when viewed against the podium of Plot 02 and the adjacent Plot 2.4 building.

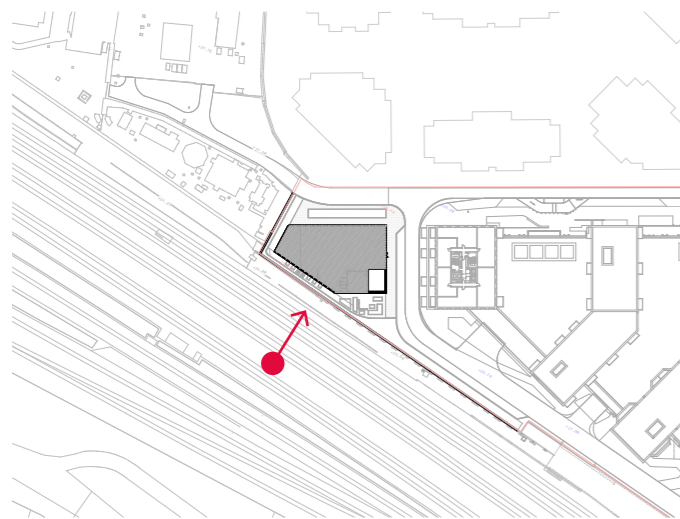

Fig 7.23: View location



Fig 7.24: Illustrative design proposal



### 7.3.6 Scale & Massing

The illustrative design of the pavilion is intentionally simplistic. A robust base, comprised of masonry or metal panels would echo the former industrial use on site. This would be contrasted by a purposefully light-weight upper element, potentially in a polycarbonate panel as illustrated on the previous pages. This upper storey could potentially be subtly back-lit at night or in the evenings to act as a beacon when viewed from the east.

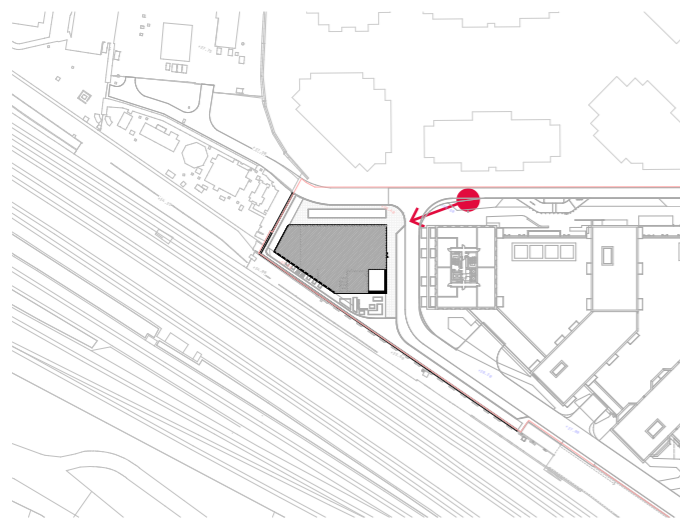

Fig 7.25: View location



Fig 7.26: Illustrative design proposal



### 7.3.7 Proposed Layout

It is proposed the LST operate from two new buildings on the site; Plot 2.9, illustrated in this section and Plot 6.2.

it is proposed that Plot 2.9 focuses on providing facilities for the trust to deliver sports and leisure activities within a building which could operate flexibly.

The illustrative proposals indicate a range of main uses, including a full size basketball court at level 02, Indoor activity hall at level 01 and multi-use flexible space at level 00. These functions would be supported by ancillary functions such as dining space, changing and workshops.

Plot 2.9 is situated adjacent to the 4no. bus stands and as such also houses a kitchenette for drivers to relax within.

The building also houses a number of substations which are designed to serve the overall site, these are located on the northern facade adjacent a service road which provides access to the Cadent infrastructure site to the west.

- ① Workshop
  - ② Multi-use / Social / Family Area
  - ③ Lobby
- ④ Bus Driver Facilities (WC x2 and Kitchenette)
  - ⑤ Electricity Substation
  - ⑥ Workshop Store
- ⑦ Store
  - ⑧ WC's
  - ⑨ Community Garden

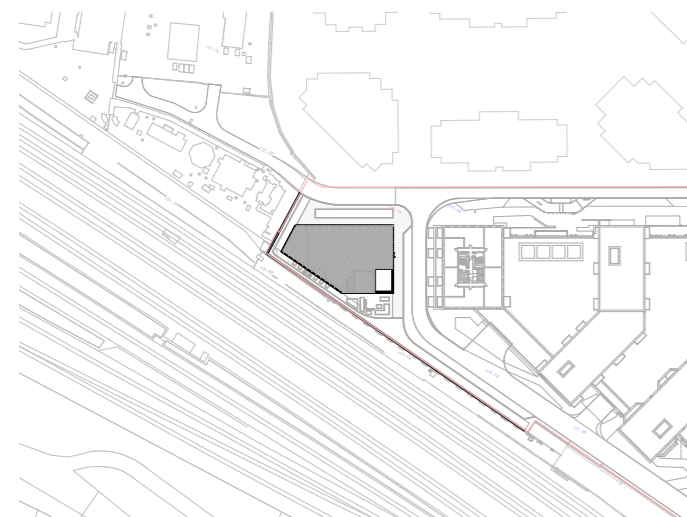
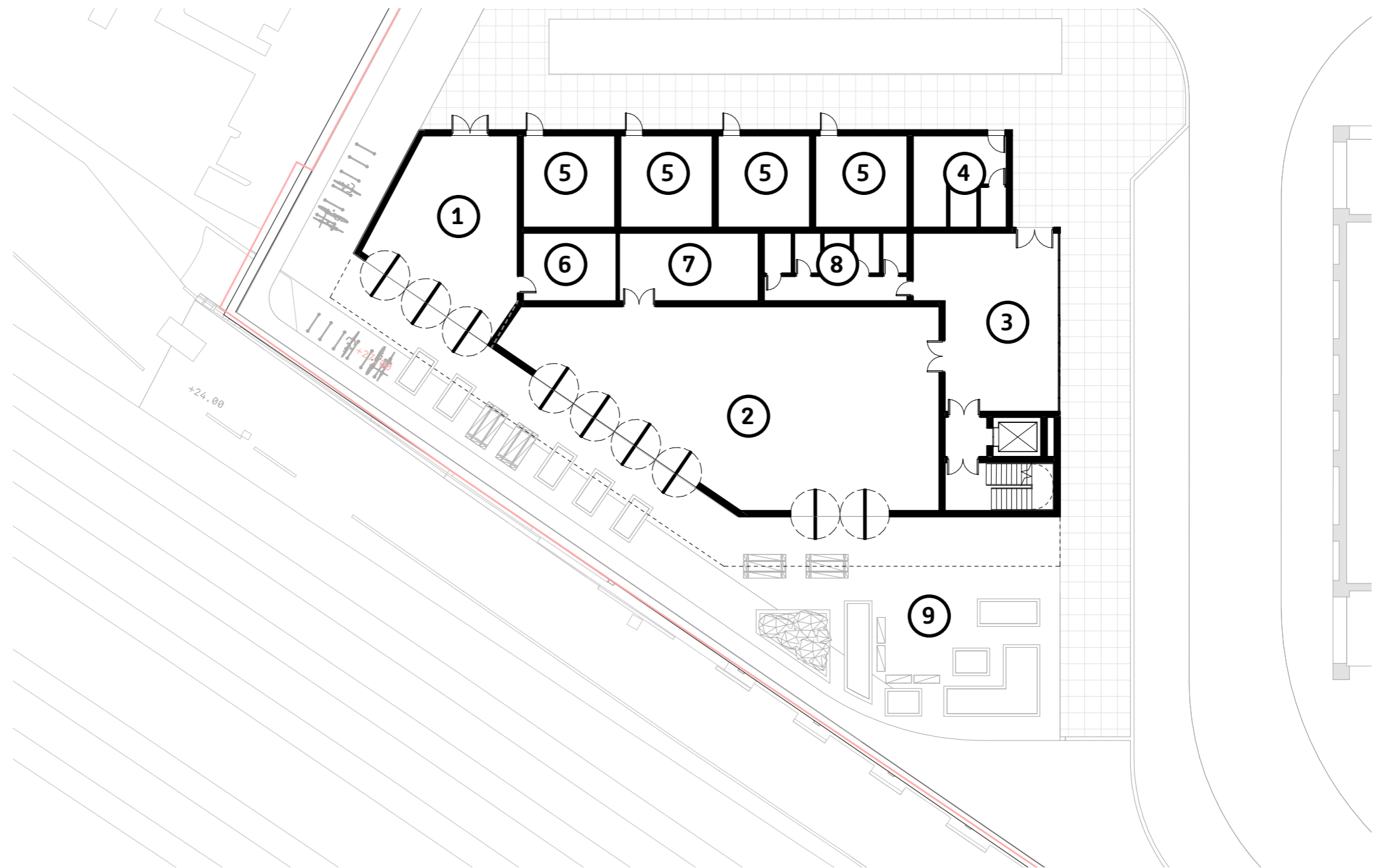

Fig 7.28: Plot location

Fig 7.27: Illustrative ground floor plan



- ① Indoor Activity Hall    ④ Male Changing    ⑦ Staff Offices    ⑩ WC's
- ② Activity Store    ⑤ Female Changing    ⑧ Change Place    ⑪ Store
- ③ Family / Social Area    ⑥ Kitchenette    ⑨ Staff Changing

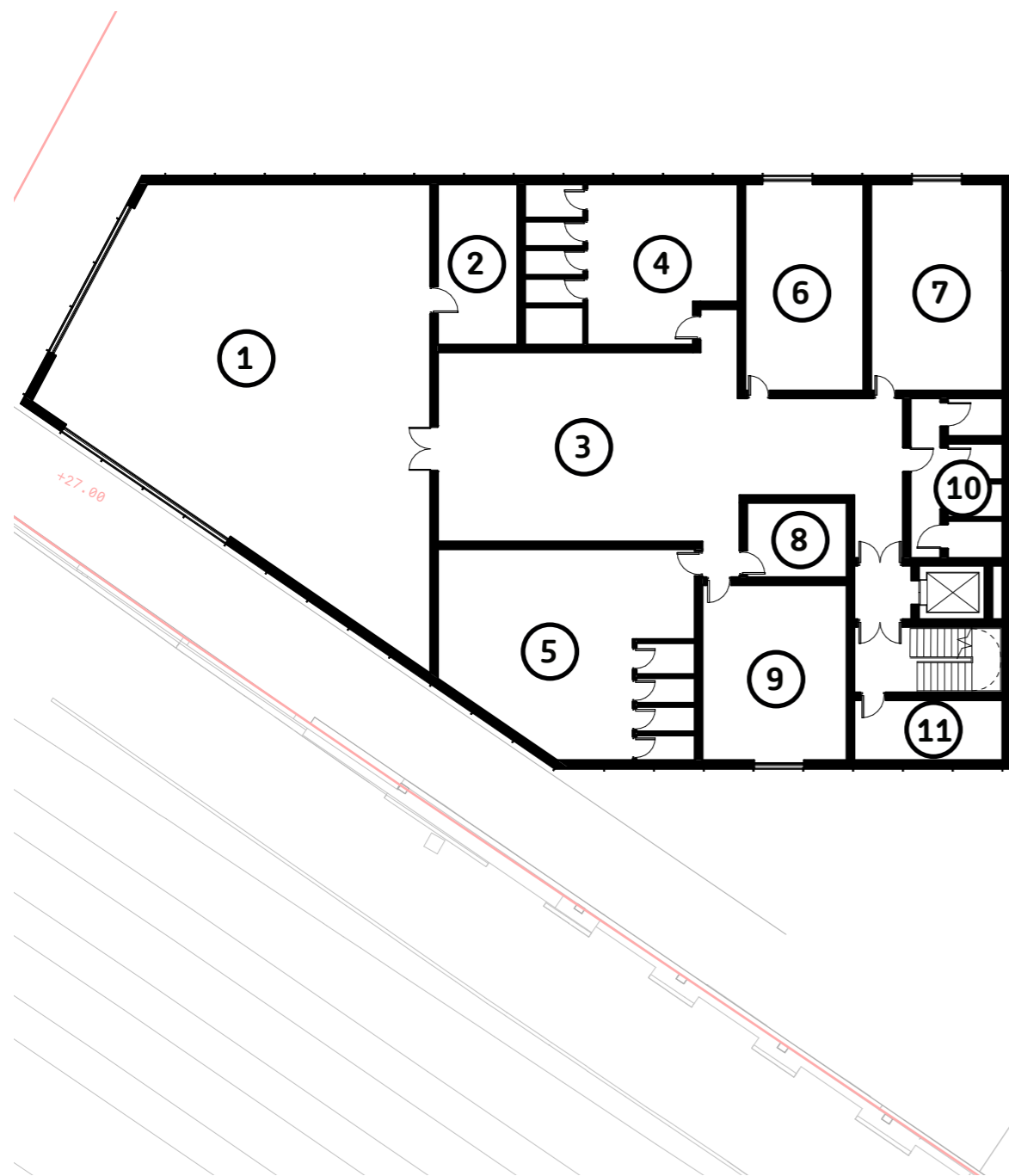

Fig 7.29: Illustrative level 01

- ① Stepped Seating    ④ Store
- ② Full Size Court
- ③ Gym / Multi use Space

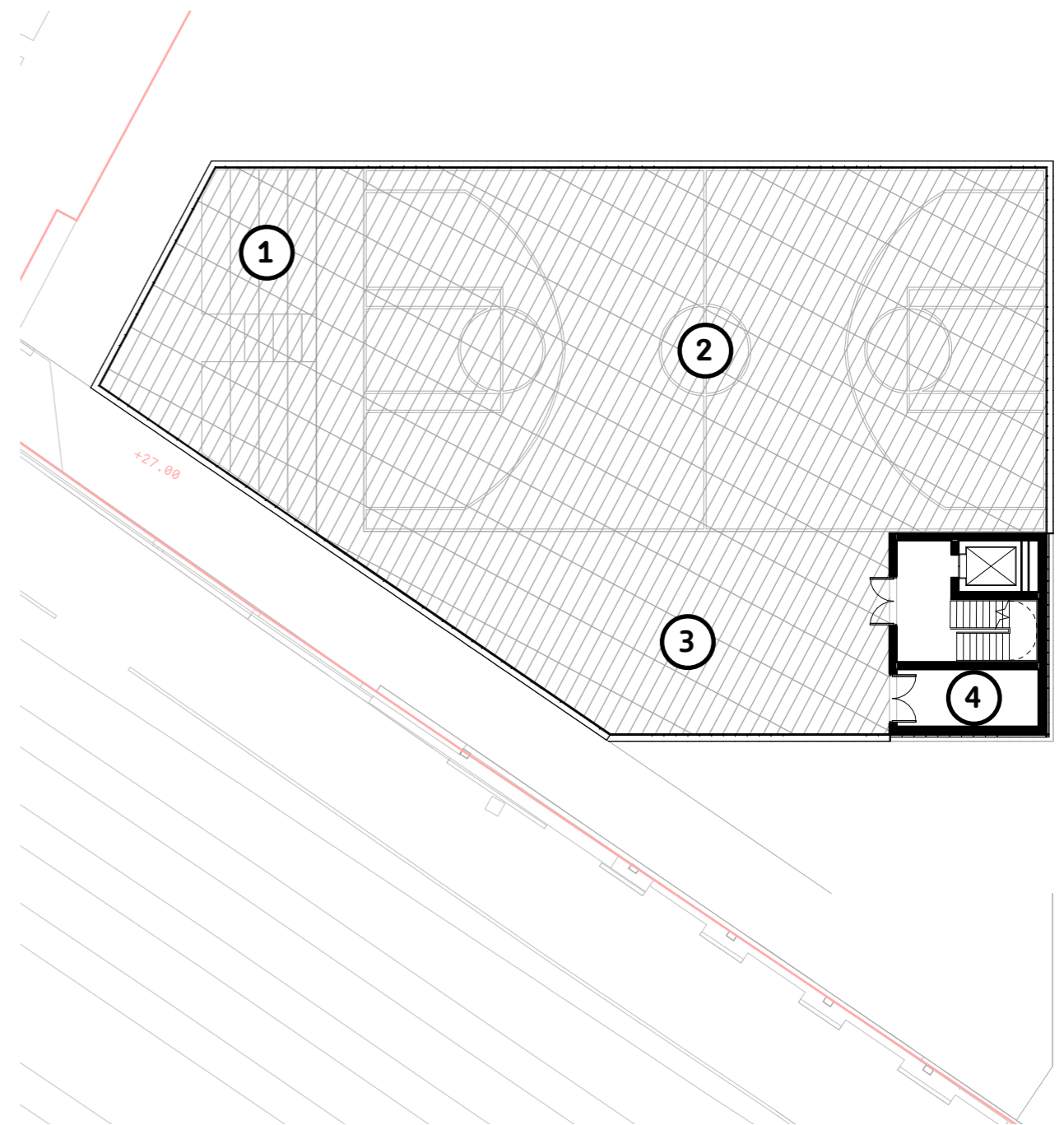

Fig 7.30: Illustrative level 02



### 7.3.8 Sports Court

Level 02 of the building has been sized to house a Basketball court with an area beyond the court for seating and set-up. The court will replace the existing external half-court, located on the southern edge of Canalside Centre and will be suitable for community use. Storage has also been included at this level adjacent the stair core.

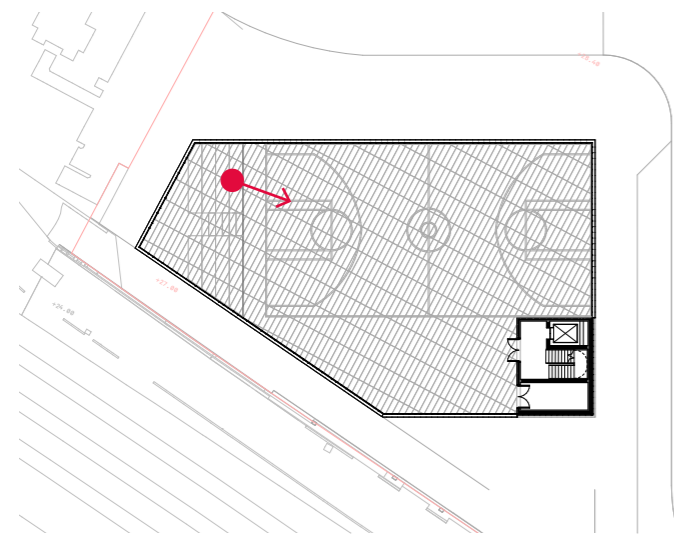

Fig 7.31: View location



Fig 7.32: Illustrative design proposal



### 7.3.9 Screening Room

Designed to operate flexibly, the upper level of the building could also be set up as a screening room or a pop-up cinema, when not in use as a sports court.

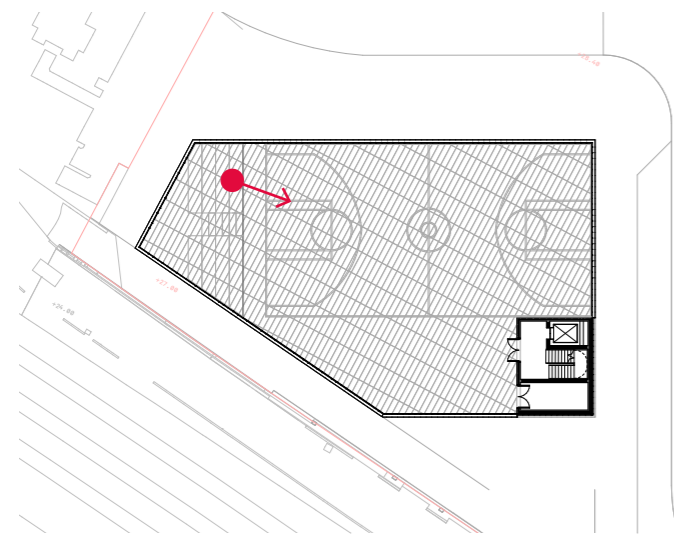

Fig 7.33: View location



Fig 7.34: Illustrative design proposal







# 8.0 Illustrative Proposals - Plot 4

<b>8.1</b>	<b>Design Summary and Explanation</b>	<b>207</b>	<b>8.7</b>	<b>Appearance</b>	<b>242</b>
8.1.1	Plot 04 Context & Analysis	207	8.7.1	Plot 4	242
8.1.2	Plot 04 Narrative	209	8.7.2	Materiality	243
<b>8.2</b>	<b>Layout</b>	<b>210</b>	8.7.3	The Tower Building (4.1)	245
<b>8.3</b>	<b>Height &amp; Massing</b>	<b>212</b>	8.7.4	The Mansion Blocks (4.2, 4.3 and 4.4)	251
<b>8.4</b>	<b>Use</b>	<b>216</b>	8.7.5	The Wharf Building (4.5)	259
8.4.1	Use	216	8.7.6	Lobbies	263
<b>8.5</b>	<b>Residential Quality</b>	<b>220</b>	<b>8.8</b>	<b>Sustainability</b>	<b>265</b>
8.4.2	Outlook, proximity and overlooking	220			
8.5.1	Aspect	222			
<b>8.6</b>	<b>Building Typologies</b>	<b>224</b>			
8.5.2	The Tower (Building 4.1):	224			
8.6.1	The Mansion Blocks	227			
8.6.2	Wharf building (4.5)	236			
8.6.3	Wheelchair adaptable units	239			
8.6.4	Basement and residential parking	240			







**Plot 04 occupies the northern-most edge of the masterplan and provides new residential homes against the calmness of the Grand Union Canal and Kensal Green Cemetery beyond.**

Plot 04 lies at a prominent moment within the masterplan, as the site transitions from its bustling eastern half to an area defined more by homes and gardens. It is positioned at the north of the widest part of the site against the canal, with views to the cemetery beyond. The massing of the blocks capitalises on this opportunity. The plot incorporates one of the large publicly accessible garden spaces within the masterplan, known as Canalside Park, which gradually opens and widens as it reaches the canal edge.

The buildings draw from the mansion block typology which is familiar both within RBKC and wider London, to create blocks which embrace the surrounding context, through integrated balconies and bay windows.



# 8.1 Design Summary and Explanation

## 8.1.1 Plot 04 Context & Analysis

### 8.1.1.1 Plot Boundaries & Constraints

The primary physical constraint to the Plot 01 site is the towpath and the Grand Union Canal to the north. Buildings are positioned back from the towpath to deliver sufficient space for the towpath to expand into Canalside Park and to allow for a landscape zone in front of residential units at ground floor level.

Plot 4 sits at to the northwest of the masterplan nestled in the bend of the canal opposite Kensal Green cemetery. The site is bounded by Plot 3 (the Berkeley St Williams site) to the west, Plot 2 (the supermarket) to the south, Plot 5 with its reinstated basin to the east and the Canal towpath to the north.

The basin to the east of plot 4 marks the shift in character in the masterplan from the more vibrant and dynamic high street and dock side wharfs to the more residential areas surrounding the garden squares to the west. This change is reflected within Plot 4, with a building lining the basin to the east responding to the character of the wharf, and the other buildings lining the central garden square being more residential in character.

The site is also defined by the geometry of the masterplan changing as it follows the curve of the canal resulting in the fan-like shape of the plot, with a generous frontage to the water and converging towards Wharf Road and the superstore. The fulcrum, at the centre of the curve, forms a tipping point in the masterplan where the orientation of the site changes and the main route through the site meets an intersection. The road turns to run parallel to the canal and a pedestrian route continues towards the bridge link across the canal in Plot 3 (the Berkeley St William site, which sits outside of our proposals and is subject to a separate planning application).

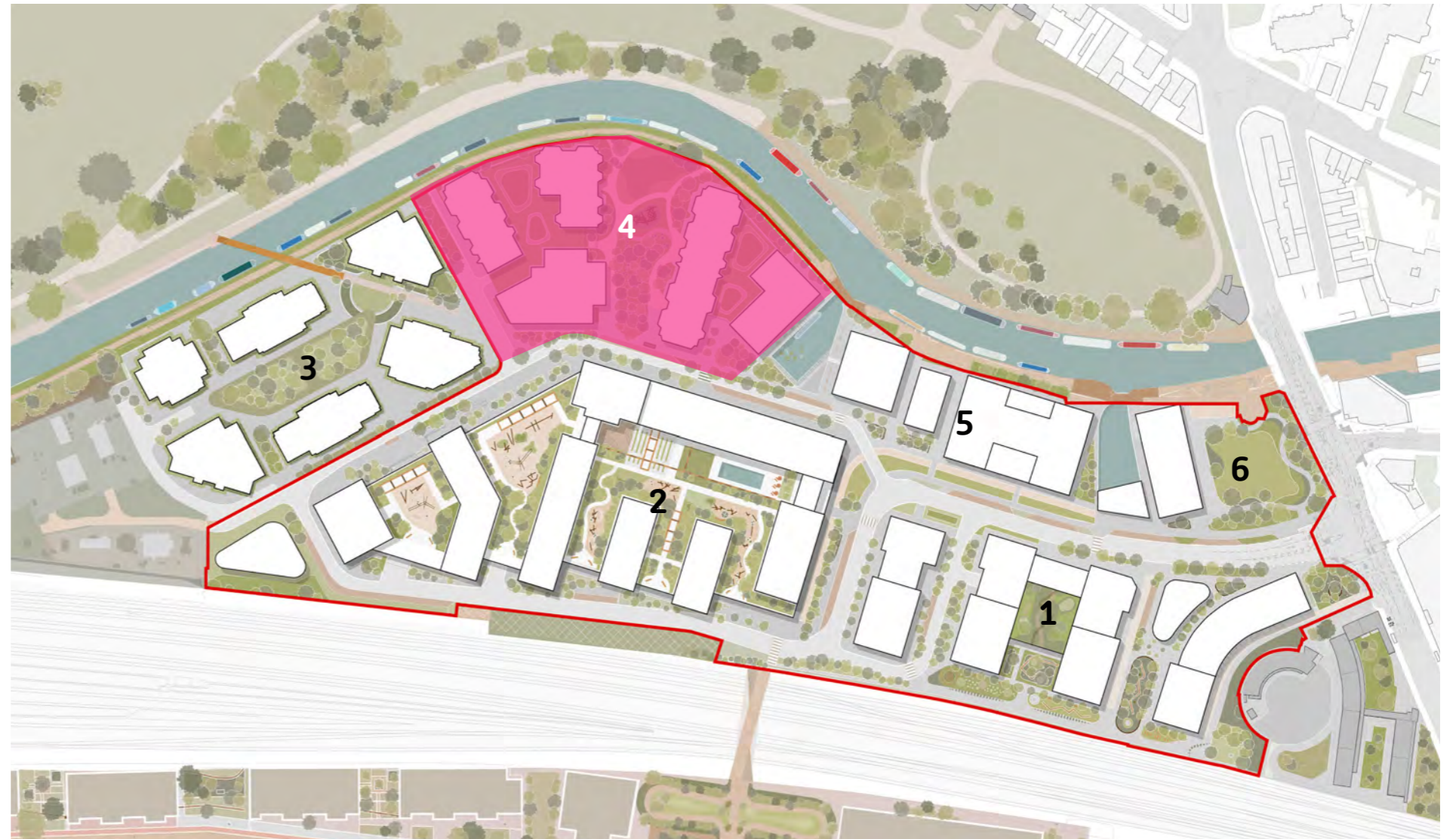

Fig 8.2: Plot 04 Extents

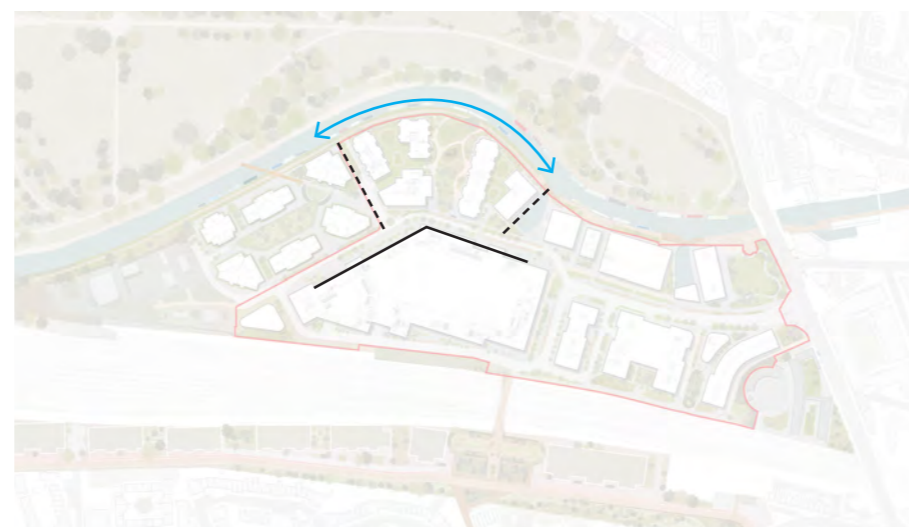

Fig 8.1: Constraints - Sainsbury's Store Frontage, canal, site boundary and reinstated basin

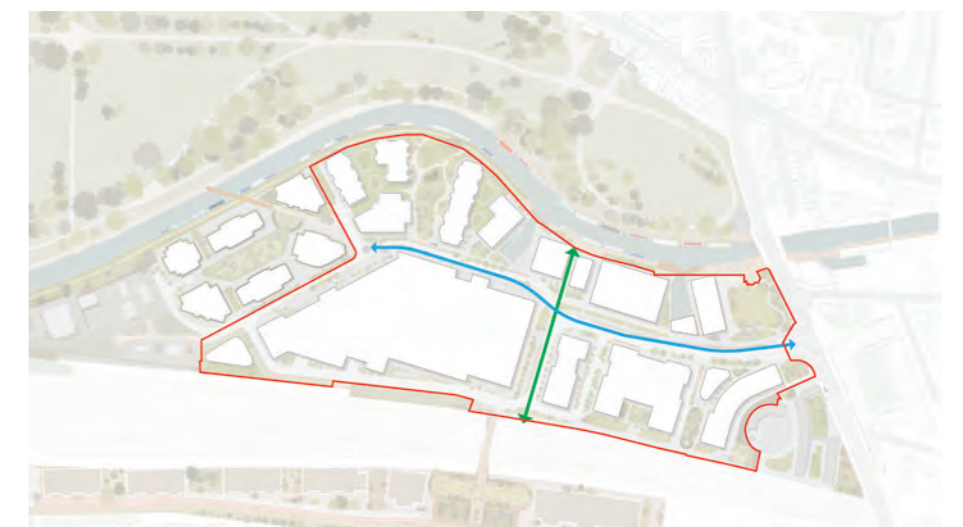

Fig 8.3: Context & Constraints: Key Splines



### Role In Masterplan

Occupying over 13550sqm on the northern-most section of the site, Plot 04 constitutes an important presence in the Masterplan by signalling the change in geometry to Plot 03 and the western edge of the masterplan. The plot also acts as a gateway between the busier eastern commercial end of the masterplan, to the more residential focus at the western edge. This transition begins at the reinstated basin and becomes more pronounced as we progress westwards.

The massing of the blocks allows for natural light to filter through the plot and for views to open up to the canal and cemetery from the principle pedestrian routes within the centre of the masterplan.

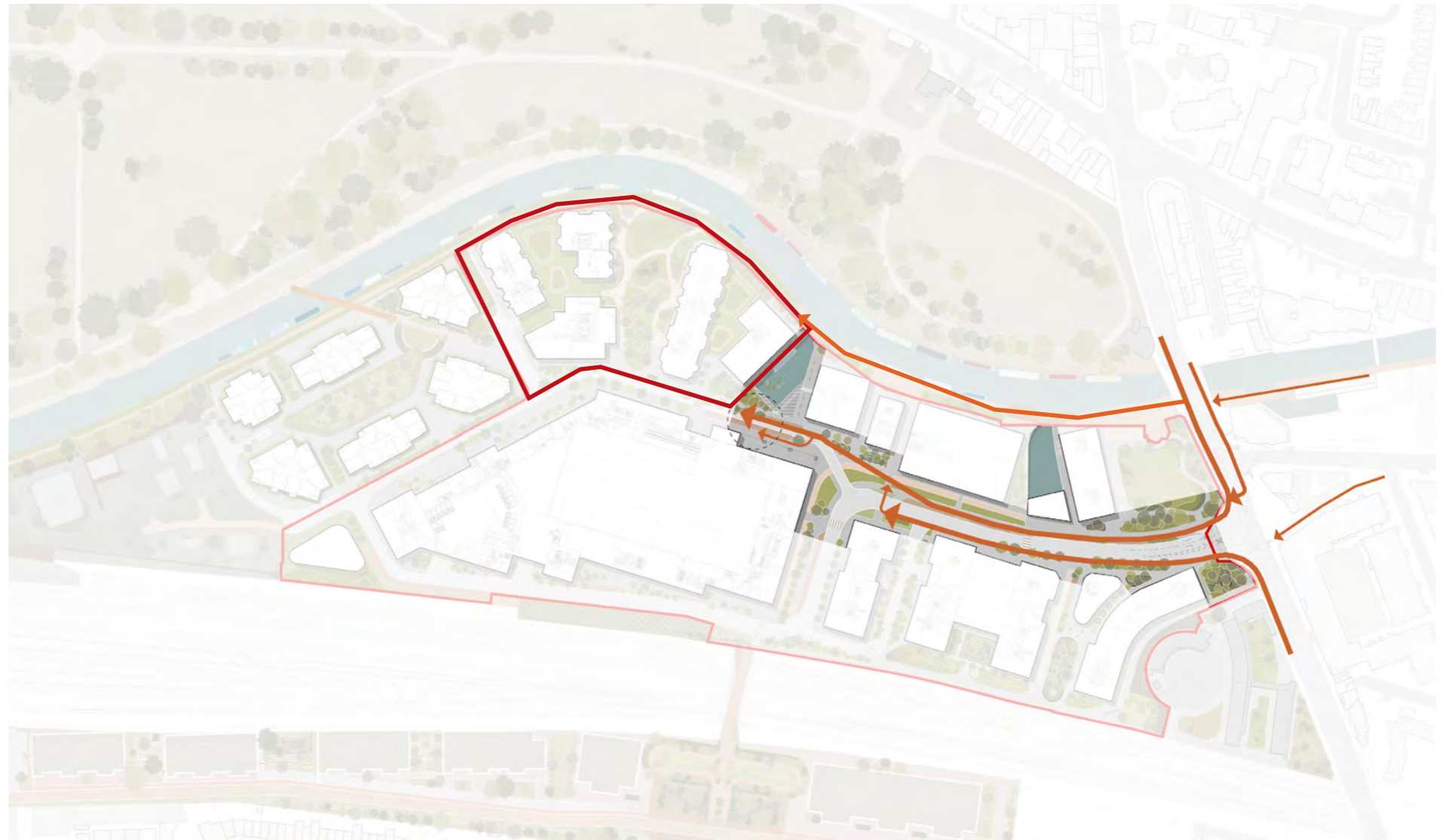

Fig 8.5: Pedestrian Experience - Main routes from Ladbroke Grove



Fig 8.4: Pedestrian Experience - Routes to Plot 04 from the south



Fig 8.6: Key views



## 8.2 Layout

### Distribution:

The proposals for Plot 4 include a large public garden that sits at the heart of the site and five residential buildings (buildings 4.1 to 4.5) that sit perpendicular to the curve of the canal in this location. The buildings are arranged around two raised courtyards, set on either side of the central garden square. Together the public garden and the residential courtyards form an ensemble of splayed landscape spaces opening out towards the canal, maximising the views across to the cemetery, and offering a green edge to the towpath. The progressive change in orientation of the buildings facilitates the transition between the buildings of Plots 3 (the Berkeley St William site) and 5 that sit either side.

The area to the west of Canalside Park contains three buildings arranged around a central raised courtyard. The Tower (building 4.1), positioned at the end of the Avenue and at the centre of the curve of the canal marks the fulcrum point where the geometry of the masterplan changes. This is the tallest building on plot 4 and sits on the corner of Canalside Park where it meets the Avenue in front of the superstore. It also works together with the tall building in Plot 3 (assuming Plot 3 comes forward in the manner expected based on the latest design iterations shared by the Plot 3 team) to signify the start of the pedestrian route to the bridge link across the canal at the start of West Drive.

To the north of The Tower (building 4.1), two mansion blocks sit either side of a landscaped courtyard that opens up offering views onto the canal and the cemetery beyond. The block to the West (building 4.2) fronts Towpath Mews the residential street separating Plots 4 and 3 (the St Williams site) and establishes the orientation of the western half of the masterplan. The block to the east (building 4.3) sits on the opposite side of the courtyard and frames Canalside Park.

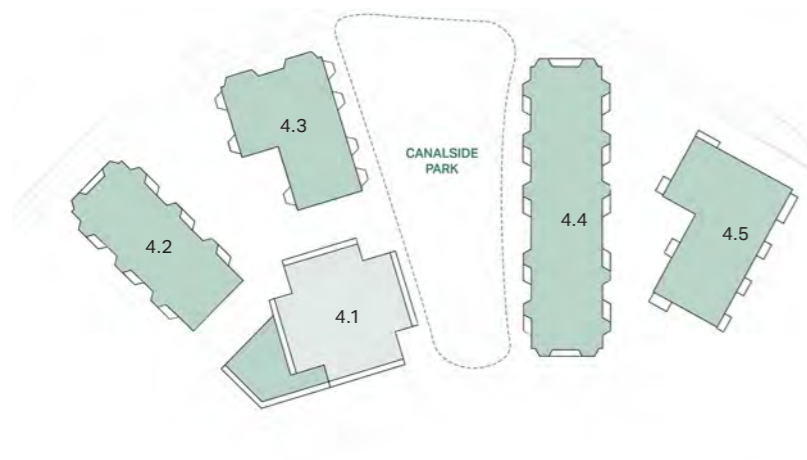

Ground floor plan



Axonometric sketch showing ground floor uses in Plot 04 (Illustrative Scheme)



A second residential courtyard sits to the east of the park and is framed by two buildings. A long mansion block (building 4.4) runs perpendicular to the Avenue in front of the superstore and the canal edge. Lining the full length of the park the building helps give the space a character reminiscent of a West-London garden square. The wharf block (building 4.5) sits on the eastern edge of the plot lining the reinstated canal basin and responds to the dockside character of plot 5 beyond.

The ground floors of the blocks have been designed to maximise active frontage to the public realm. In the most prominent locations facing the superstore along Wharf Road and along the New Wharf, the ground floor is devoted to commercial uses that are occasionally interspersed with residential entrances. The rest of the ground floors, including both sides of the park and the residential street to the west, are raised up by 800mm and contain residential accommodation. The raised ground floors ensure a reasonable balance is achieved between safeguarding residents' privacy and making a positive contribution to the character and the activation of the public realm.

The adjacent plan shows an extract of the ground floor of the masterplan. The numbers relate to the following

- 4. Denby Square, at the west of The Avenue
- 5. New Wharf, to the east of Plot 4.5
- 6. Canalside Park
- 10. Lowered Boundary Wall
- 12. New Sainsburys Store

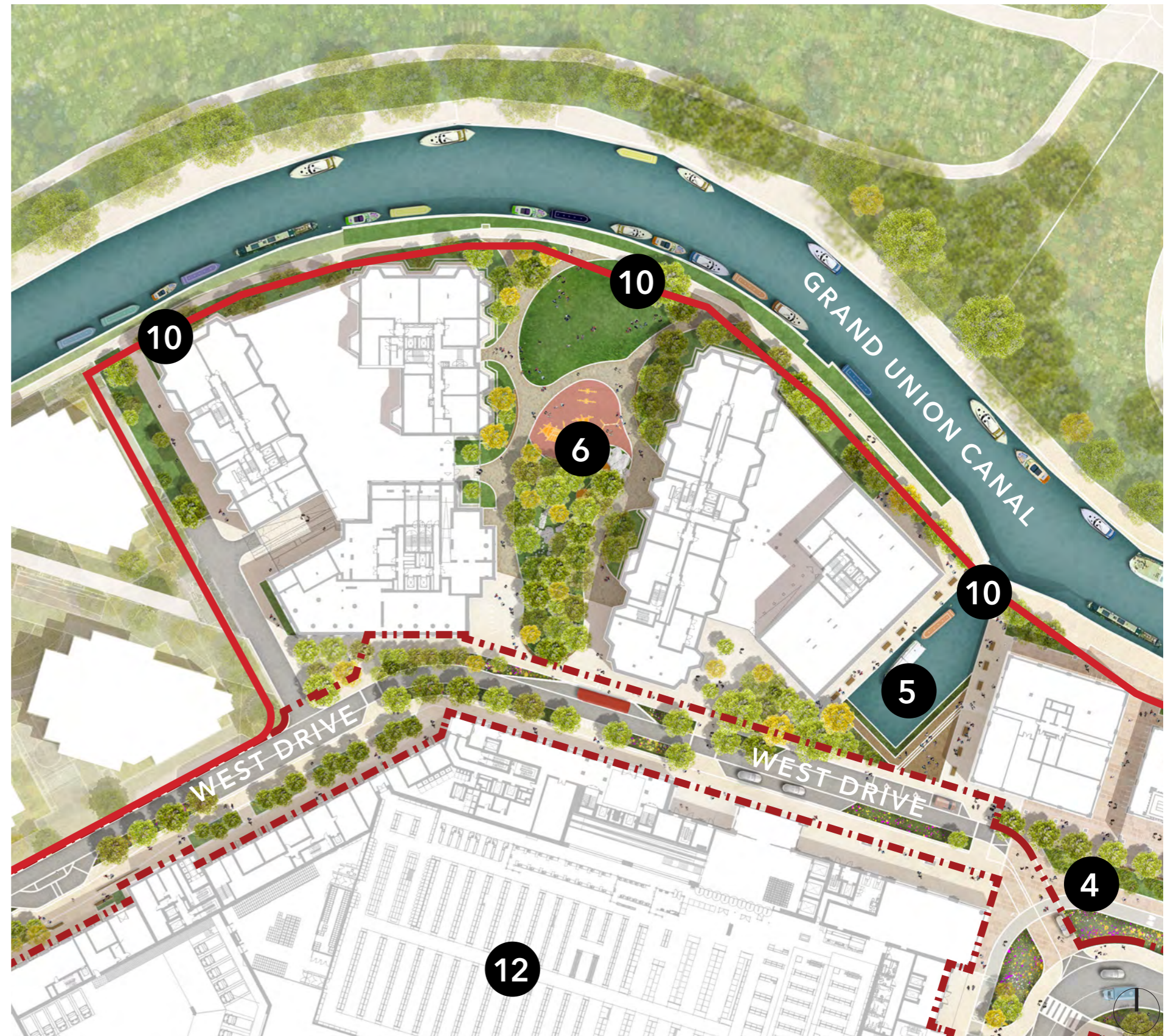

Ground floor plan (Illustrative Scheme)



## 8.3 Height & Massing

This section should be read in conjunction with the rest of the masterplan and detailed Heritage, Townscape and Visual Impact Assessment prepared by The Townscape Consultancy and Turley which contains detail on the building's impact on specific viewpoints agreed in consultation with Royal Borough of Kensington & Chelsea Planning Officers, as well as surrounding heritage assets.

The scale and height strategy of Plot 04 has evolved through careful and thorough testing of the massing and composition of the various building elements. The proposals include five buildings set either side of a central public park and arranged around two residential courtyards.

### The Mansion Blocks and Wharf Building

The four buildings lining the edge of the site to the north are splayed to follow the curve of the canal, maximising views out from the courtyards and the park and offering a green edge to the canal. The massing of these buildings has been carefully studied to offer an elegant and considered frontage to the cemetery. In accordance with the masterplan massing strategy, buildings heights are reduced against the canal edge.

### The Tower

The Tower (building 4.1) is an important marker in the masterplan, sitting at its heart and responding to the change of orientation of the main east-west geometry of the Avenue, framed by Plots 01, 02 and 05 and the gentle sweep of the canal as it turns south. The building sits centrally within the deepest part of the site and is positioned at the centre of the canal's radius, naturally making it distinct from other buildings on site. Building 4.1 and 4.3 are also the only buildings on site facing true north, which again acknowledges the canal sweep and site depth but also acts to open the Canalside Park up at its northern edge. These factors help to define Plot 4.1 as a moment for height within the masterplan. The Tower is 29 storeys within the illustrative scheme and sits on a nine-storey shoulder.



Bird's eye view sketch of plot 4 (Illustrative Scheme)



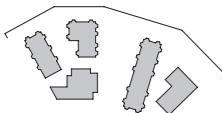

North elevation of plot 4 (Illustrative Scheme)





### 8.3.1.1 Distance between buildings

In order to maximise the area available to the public open space, the distance between buildings has been carefully balanced. The buildings have been arranged in a radial pattern perpendicular to the curve of the canal, ensuring that the closer proximities are localised and generally elevations address each other obliquely. The shape and massing of the blocks allows the internal layouts to be arranged so that key habitable spaces don't look directly at each other.

Great care has been taken to ensure that the building proximity is not detrimental to the residents. The following diagram shows the approximate distance between windows in the different buildings. These separation distances have been secured through the maximum building footprints as shown on the supporting Parameter Plans.

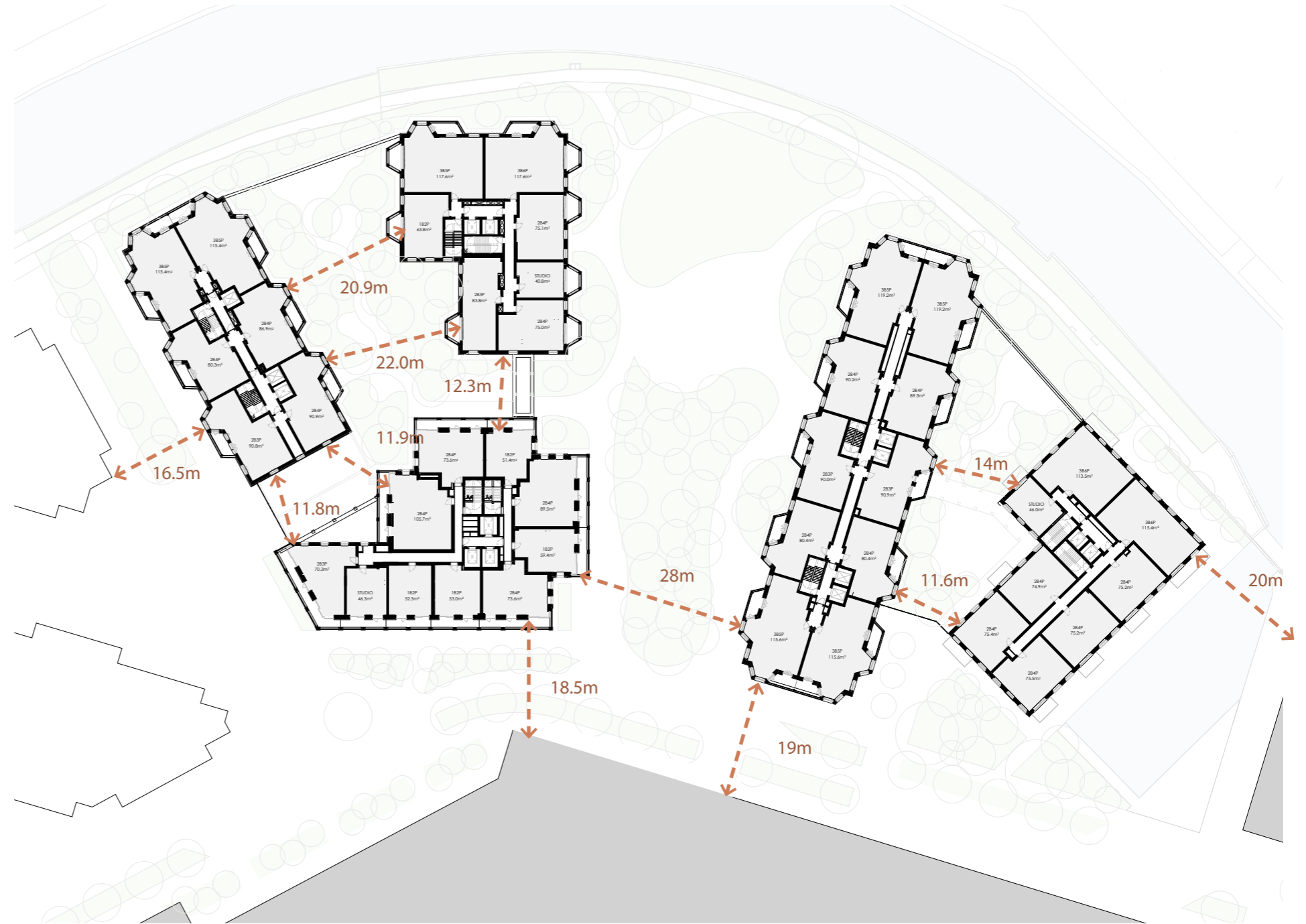

Plan showing distances between buildings (Illustrative Scheme)



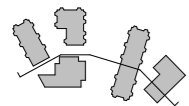
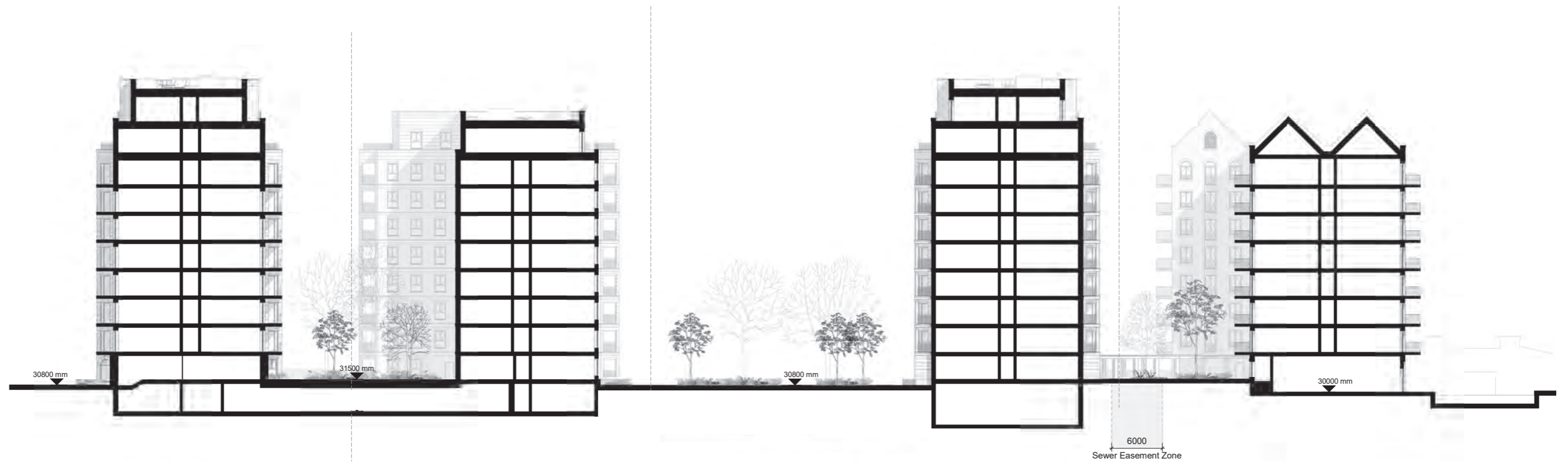

East-West section across plot 4 (Illustrative Scheme)

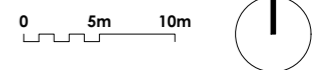



# 8.4 Use

## 8.4.1 Use

The proposal includes a predominance of residential use (C3) and flexible commercial (Class E) and community (Class F2) uses at ground floor.

### Public spaces

The proposals for plot 4 are centred around two new significant public spaces within the wider masterplan, the central garden square that sits in the middle of the plot and the canal basin along its eastern edge. Located at the heart of the site, Canalside Park stretches from the Wharf Road in front of the superstore to the canal towpath, widening as it reaches the water. This large publicly accessible garden square sits within the more residential part of the masterplan, creating a green setting for the buildings and integrating playable elements and opportunities for exercise and contemplation. The existing humpback bridge along the canal towpath marks the entrance of the former canal basin that used to serve the old gasworks in this location. By reinstating the basin within our proposals, the activity of the canal is brought into the site, the bridge is returned to its former use and a new public space is created. Lined with shops, cafés, trees and landscape the basin is a vibrant and active destination. It sits on the other side of the street to the main entrance to supermarket.

A third smaller space called Bridge Place sits to the west of Canalside Park where Wharf Road meets West Drive. This space facilitates the pedestrian route running through the masterplan that links up with the new pedestrian bridge across the canal in Plot 3 (the St William site).

### Non-residential uses

A mixture of commercial and community focused uses are provided at ground floor level of the blocks fronting onto the Wharf Road and the canal basin. These units are sized to provide useful services to the new residents and the wider community. They will also contribute to employment on site and create an active streetscape. The commercial areas lining the New Wharf and entrance to the park create excellent opportunities for cafés and restaurants that will animate the waterfront and landscape spaces that they spill out onto. The commercial or community spaces fronting onto Bridge Place will provide an active and animated civic frontage to the pedestrian route running through the site that links up with the new pedestrian bridge across the canal in Plot 3.



Key spaces around Plot 4 (Illustrative Scheme)





View of Canalside Park from the cemetery



### Residential uses

There are a range of tenures distributed throughout the plots in the wider masterplan development with Plot 4 containing market sale units. Plot 4 consists of high quality apartments of private tenure and will provide a range of unit sizes. Private outdoor amenity space has been provided to the units with direct level access to a generous terrace, loggia or balcony. Some larger units have access to more than one external amenity space. All private amenity spaces are deep enough to ensure that at least four occupants can easily sit and circulate around a table regardless of the size of the unit.

Private communal residential amenity will be provided in the form of a two courtyard gardens. Located at the raised ground level, these courtyard gardens have level access from the residential cores and enjoy great views out to the canal and the cemetery beyond.

### Ancillary uses

There are a series of ancillary uses such as car & bike parking, bin & maintenance stores as well as various plant rooms within Plot 4. Most of these will be located in a basement that runs under the majority of the plot. For access purposes some of these may need to be located at ground floor level such as some bin stores and substations. These will be located to minimise any areas of dead frontage to the public realm.

### Canalside Park

Located between the mansion block buildings of Plot 4.3 and 4.4 is the new Canalside Park. This is generously proportioned to provide a range of experience for residents and passers-by alike. On its southern edge, the park is densely planted to create a woodland experience. Toward the edge of the canal the park opens up and a large grassed area is presented suitable for play and relaxation in this well lit area.

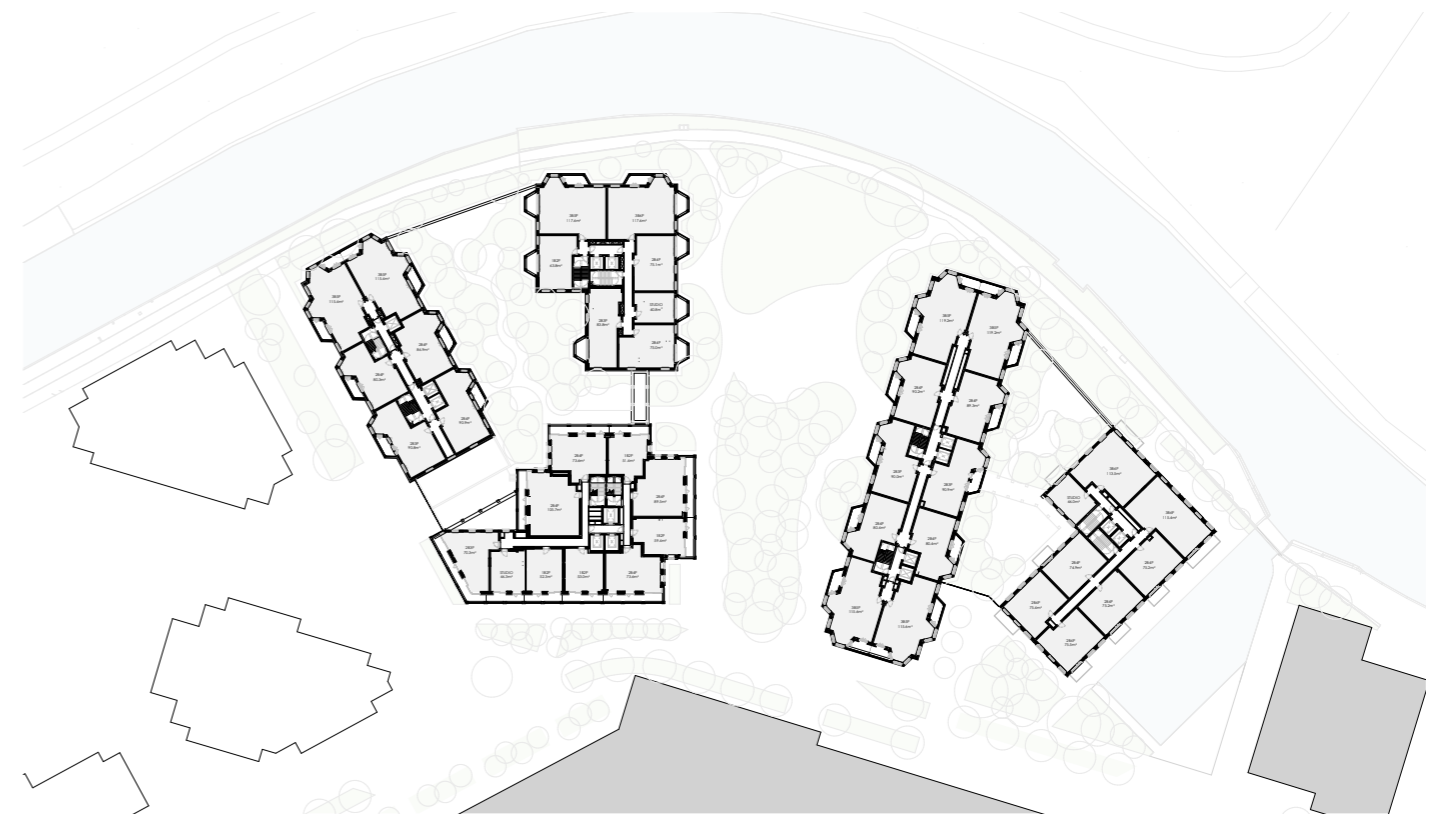

Typical floor tenure plan (Illustrative Scheme)



Basement plan (Illustrative Scheme)



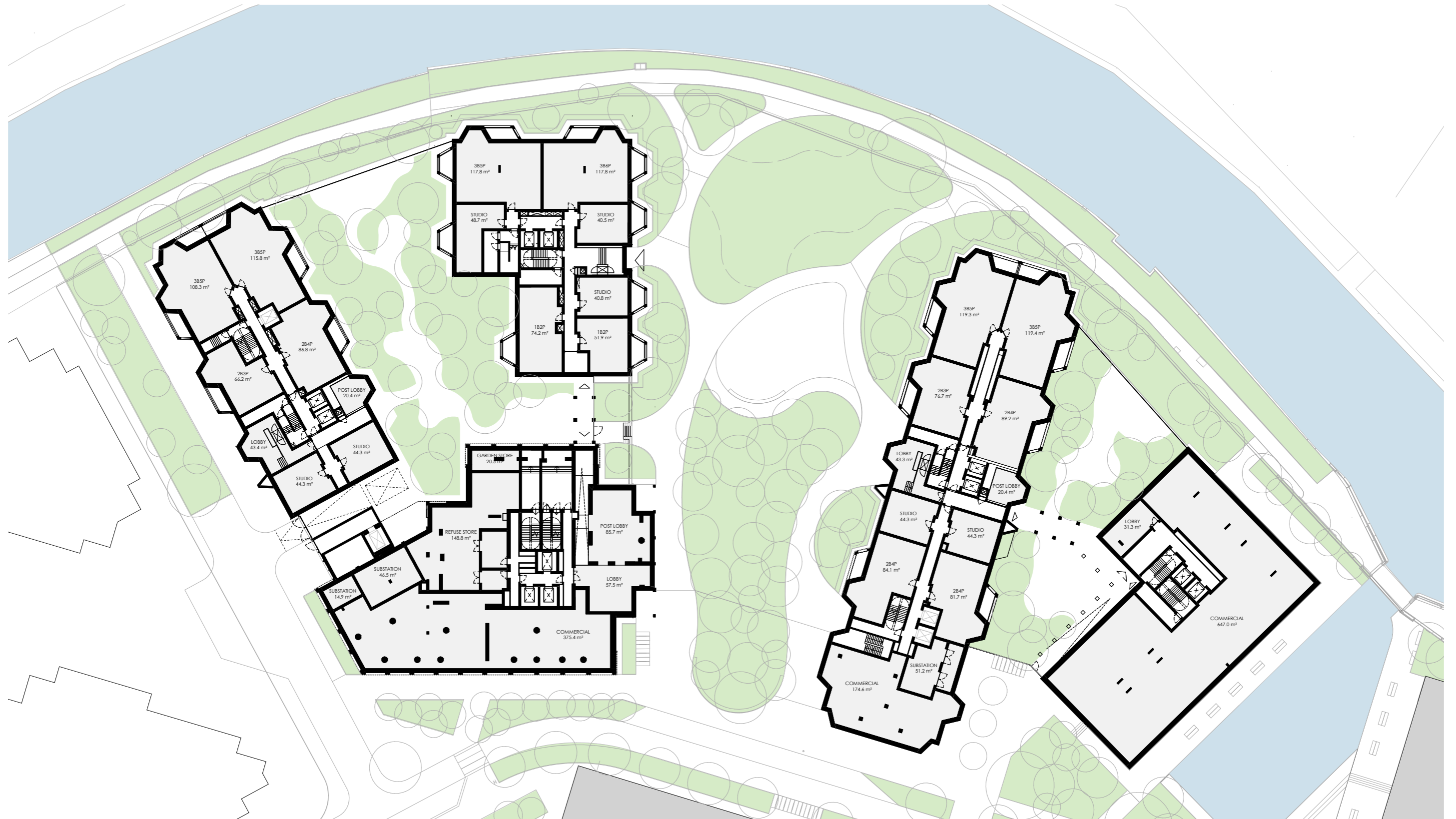

Ground floor tenure plan (Illustrative Scheme)



# 8.5 Residential Quality

## 8.4.2 Outlook, proximity and overlooking

The distribution of the five buildings within Plot 4 has been carefully considered to maximise long views out of the residential units. The blocks are laid out perpendicular to the curve of the canal forming a splayed orientation. This creates a series of triangular spaces opening towards the water, increasing opportunities for diagonal views towards the canal. This also ensures a more permeable and varied composition to the frontage facing the cemetery. This strategy of creating oblique views is further reinforced by the addition of bay windows, giving the living rooms of the mansion blocks a variety of outlooks, north to the canal and south to the sun.

As a result of the splayed geometry and in order to maximise the area available to the public open space, the distance between the various buildings is reduced as you move away from the canal. Great care has been taken to ensure that this proximity is not detrimental to the residential amenity. The arrangement of the buildings and the positioning of windows allows for long views past these 'pinch points' and minimises the amount of overlooking. Refer to the Scale chapter of this report for more detail.

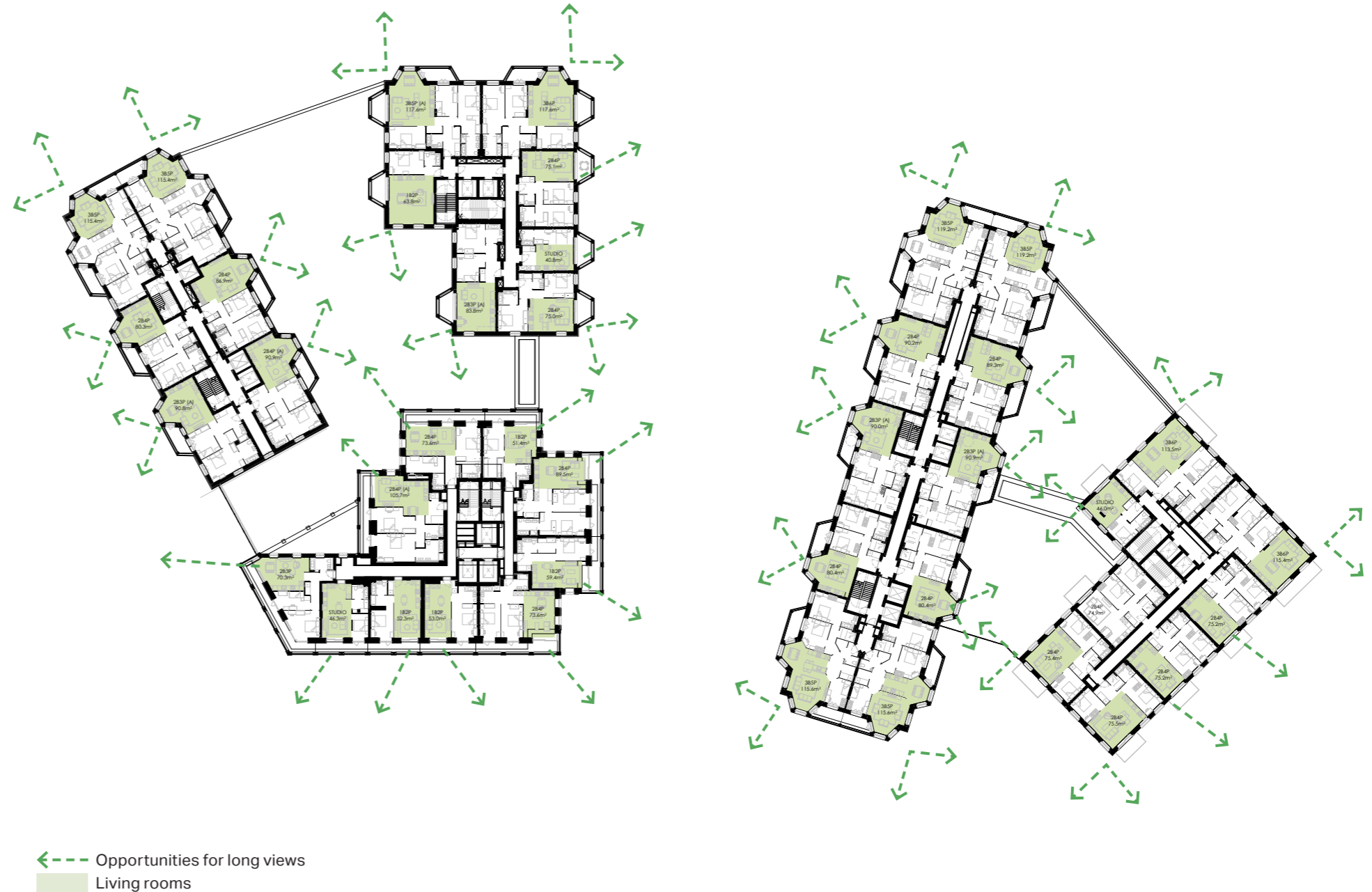

Typical floor highlighting the location of Living rooms and potential for long views (Illustrative Scheme)

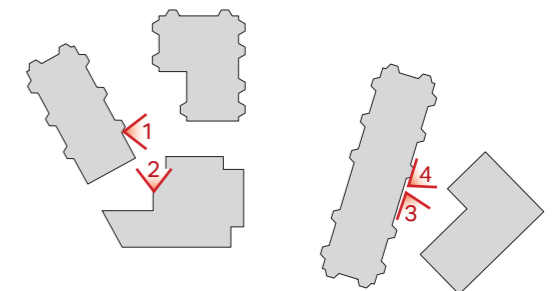

Location of views on facing page





View 1: Looking East from 4.2



View 2: Looking North from 4.1



View 3: Looking South from 4.4



View 4: Looking North from 4.4



## 8.5.1 Aspect

The design seeks to maximise the number of dual aspect units. All larger apartments, 3-bedroom and above and some 2-bedroom units, have at least two aspects and where possible living rooms have been placed on the corners to benefit from the different orientations. The 'Pinwheel' layout of the Tower was developed to ensure every unit on a typical floor is dual aspect and has a living room on the corner. In total, 75% of dwellings have a double or triple aspect. There are no single aspect north facing units in Plot 4.

While we have not counted the multiple aspects from the bay windows to the mansion blocks within these figures, they will mean the vast majority of units in Plot 4 will enjoy a variety of outlooks in different orientations.



- Single aspect units
- Double aspect units
- Triple aspect units

Typical floor (Illustrative Scheme)



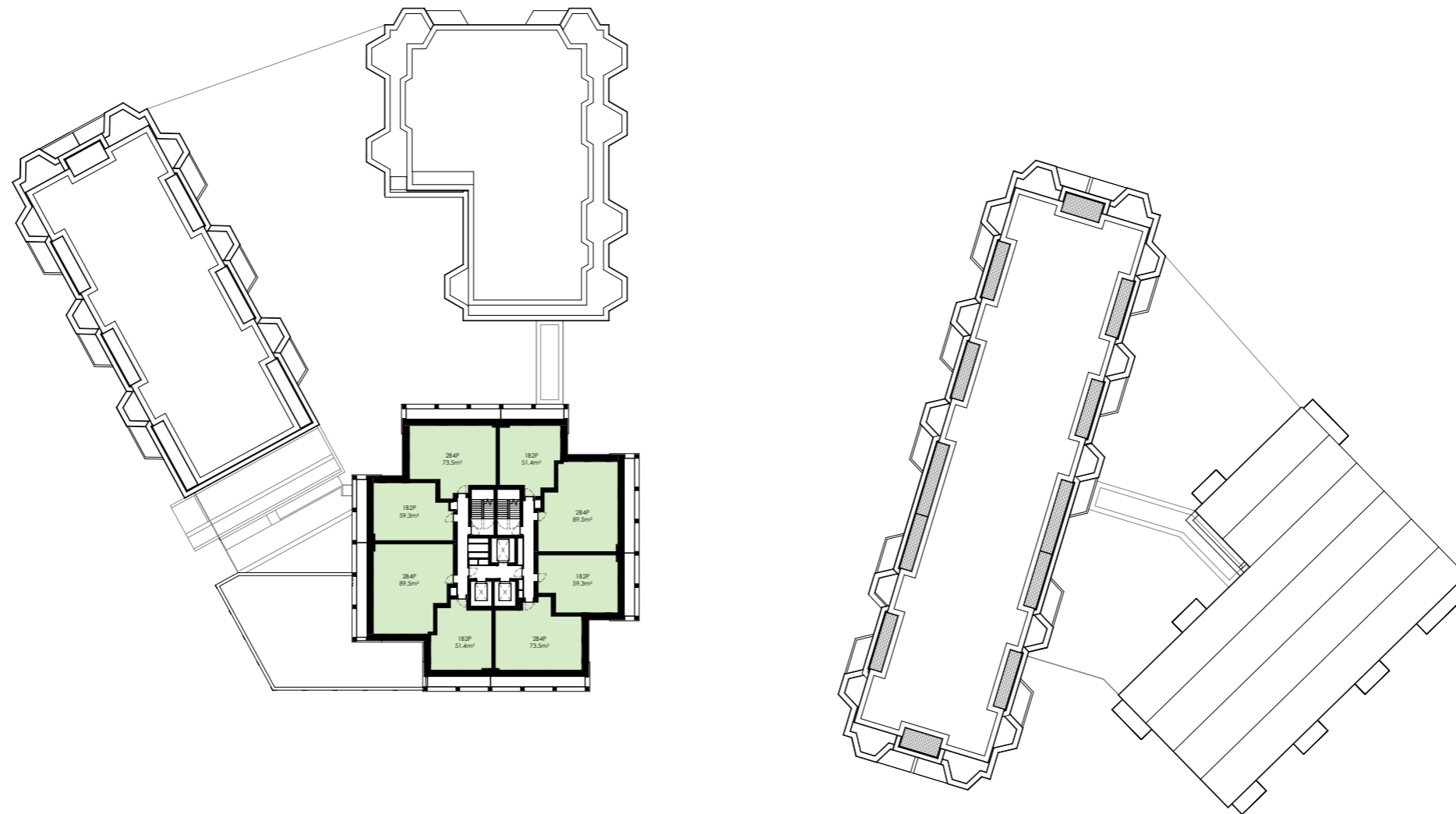

- Single aspect units
- Double aspect units
- Triple aspect units

Typical upper floor (Illustrative Scheme)



## 8.6 Building Typologies

### 8.5.2 The Tower (Building 4.1):

The ground floor is divided in three areas. Commercial and community uses will line the frontage of West Drive. The residential units in the Tower are accessed via a large lobby and post room opening onto Canalside Park. A single core with three lifts and two stairs serves the building and there is no residential accommodation at ground floor level.

The faces of the tower are lined with a loggia offering a generous balcony to each unit, and the corners are recessed ensuring every dwelling is dual aspect and has a corner living room. The layout of the building is designed to maximise the number of dual aspect units, with every unit on the typical upper floor benefiting from a corner living room.

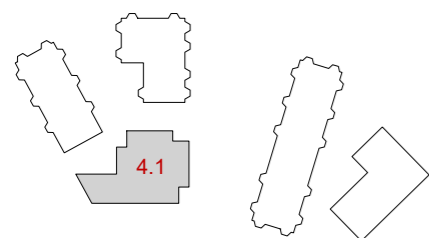
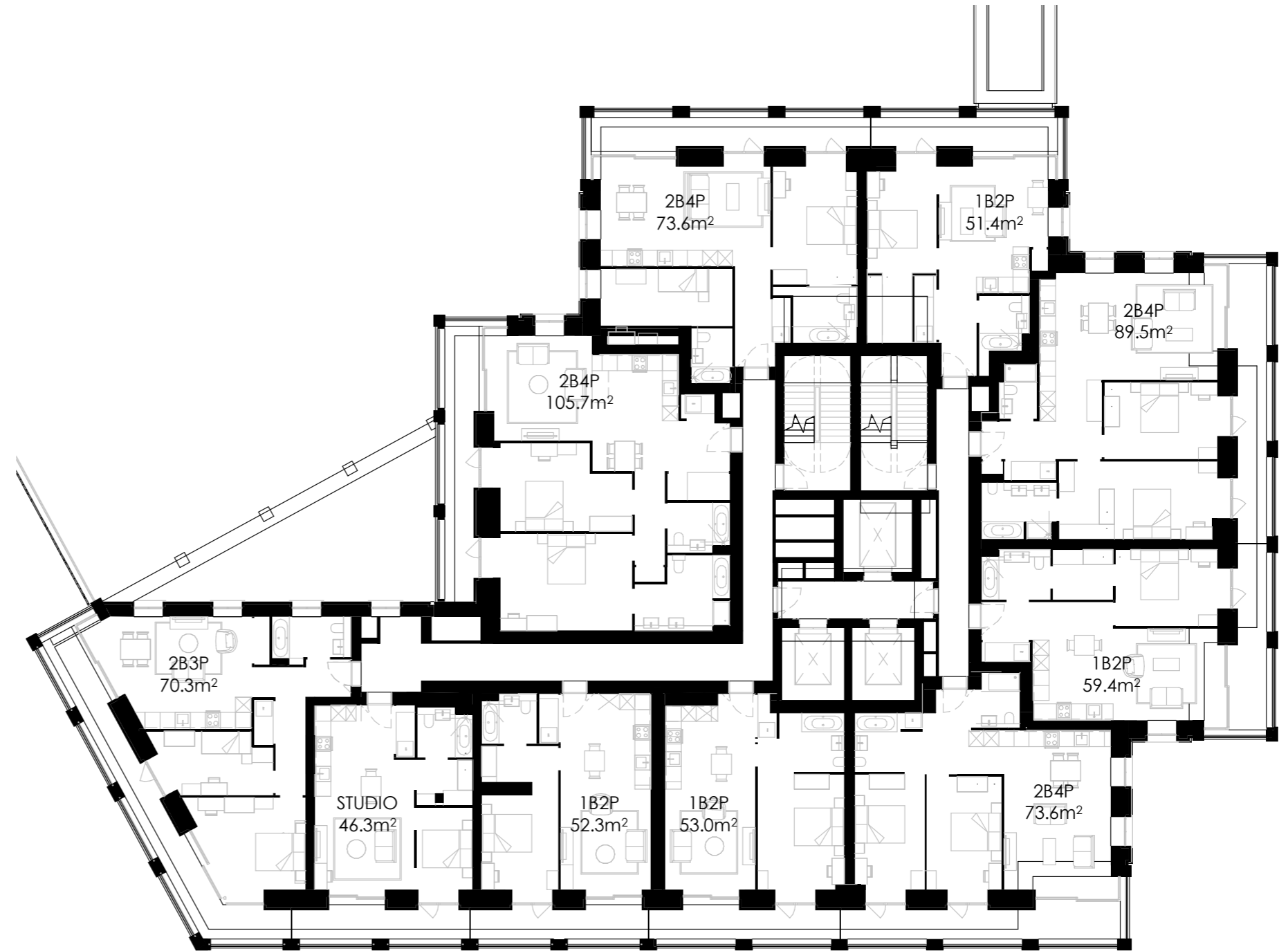



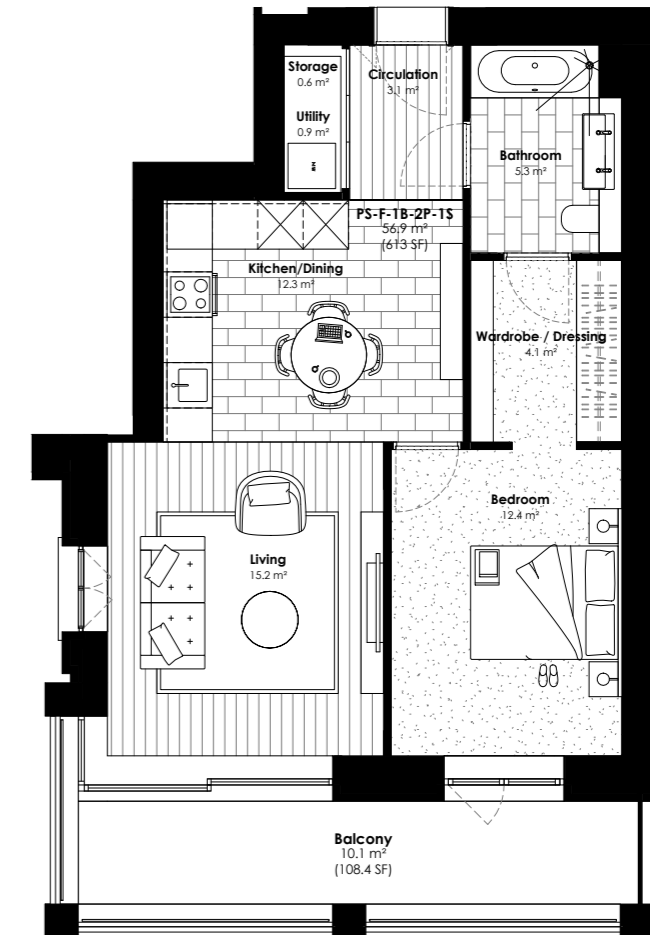

Typical 1 bed 2 person flat in the Tower (Illustrative Scheme)



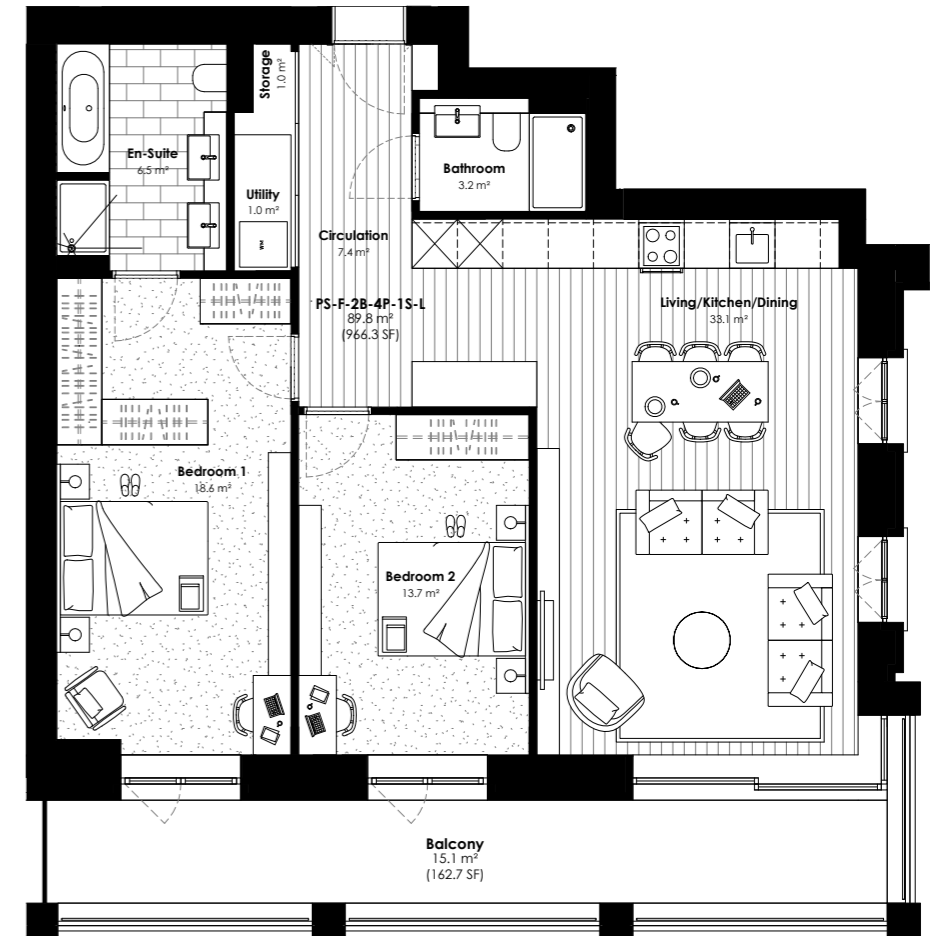

Typical 2 bed 4 person flat in the Tower (Illustrative Scheme)



## 8.6.1 The Mansion Blocks

### 8.6.1.1 Building 4.2

Building 4.2 sits to the north of the Tower and lines the residential street separating Plot 4 from Plot 3 (the St William site) to the west. It is a fully residential building and has a raised ground floor allowing for dwellings at ground floor to sit comfortably overlooking the public realm. The courtyard sits at the same level as the raised ground floor, allowing level access to the communal garden from the core and giving the raised courtyard exceptional views out across the canal and Kensal Cemetery beyond.

The building's core will be designed to accommodate two entrances, a more formal entrance to the street at lower ground level, and a second entrance from the courtyard at raised ground level.

In the illustrative scheme, larger units have been located on the prominent corners overlooking the canal to maximise dual aspects. There are generous bays to all the living rooms, allowing diagonal views to the canal and maximising opportunities for natural light and ventilation.

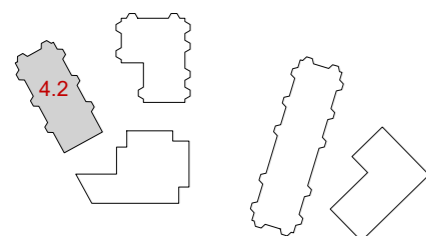
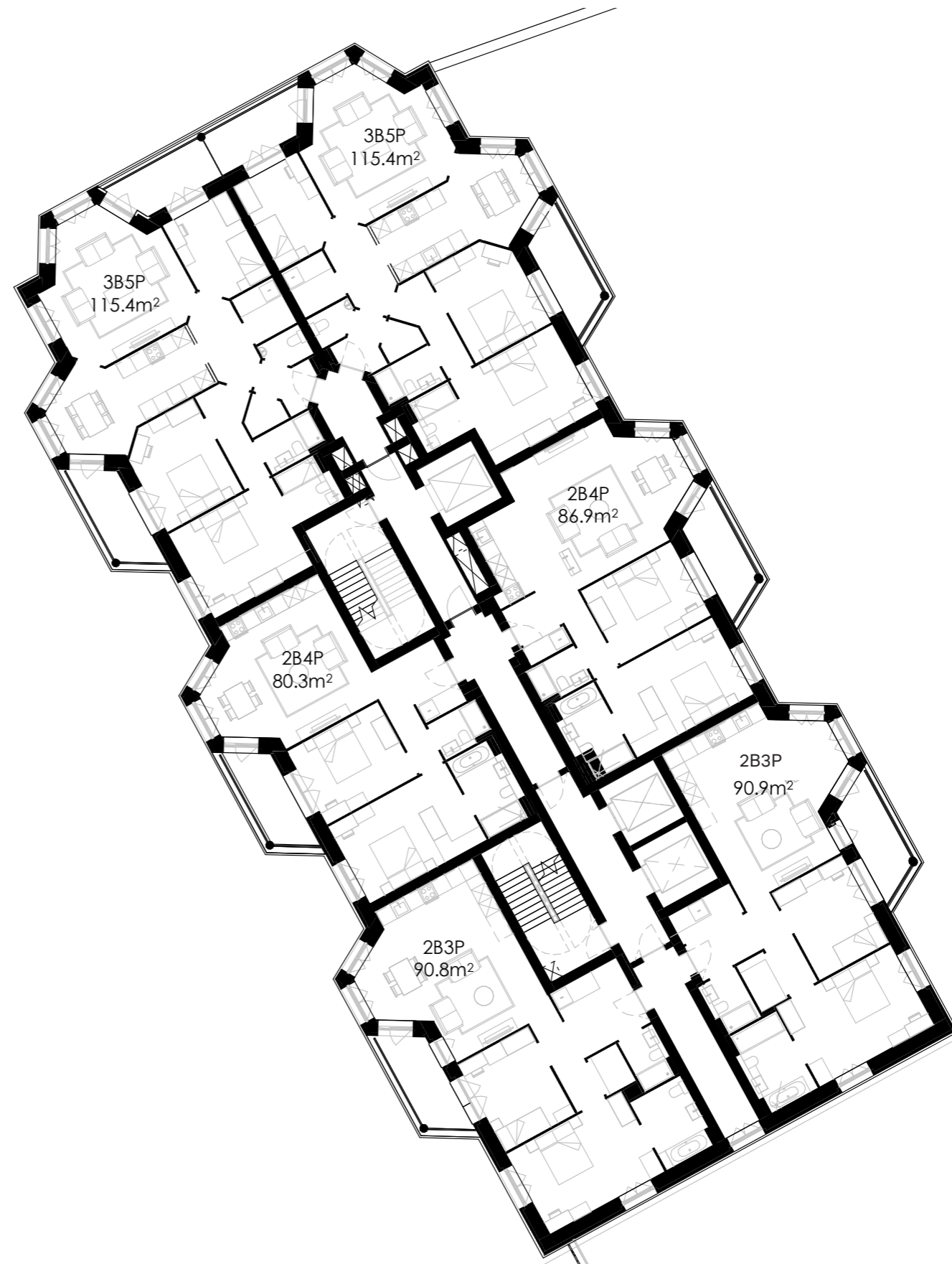

Building 4.2 Typical Upper Plan (Illustrative Scheme)





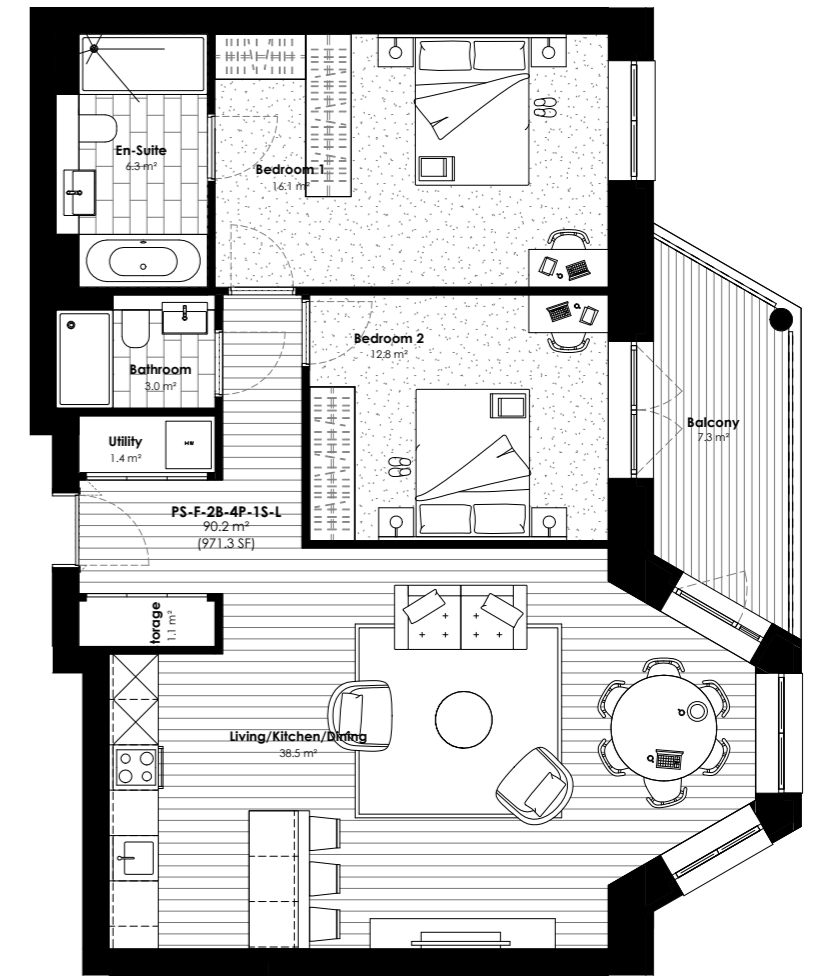
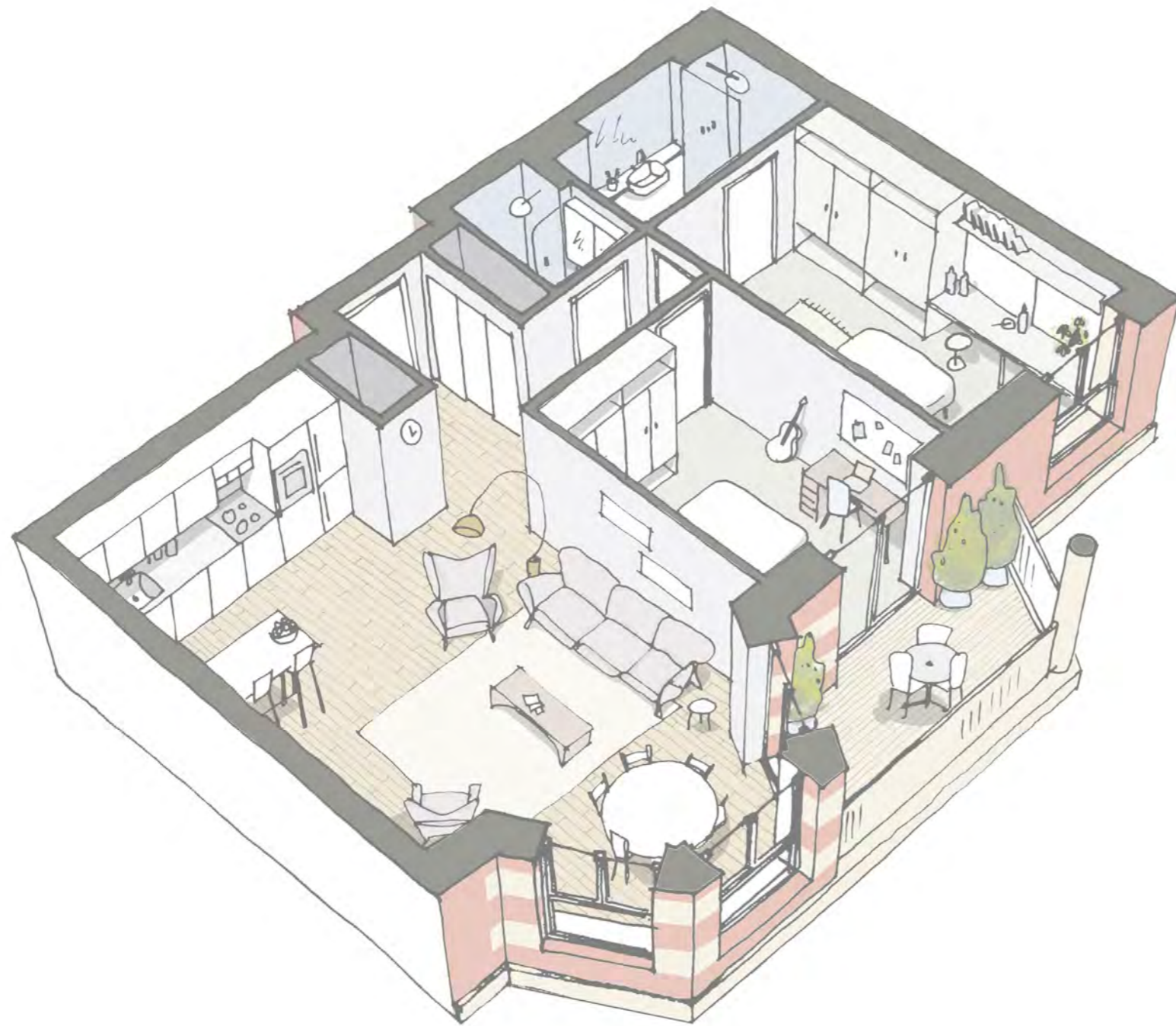

Typical 2 bed 4 person flat in the Mansion Block (Illustrative Scheme) s



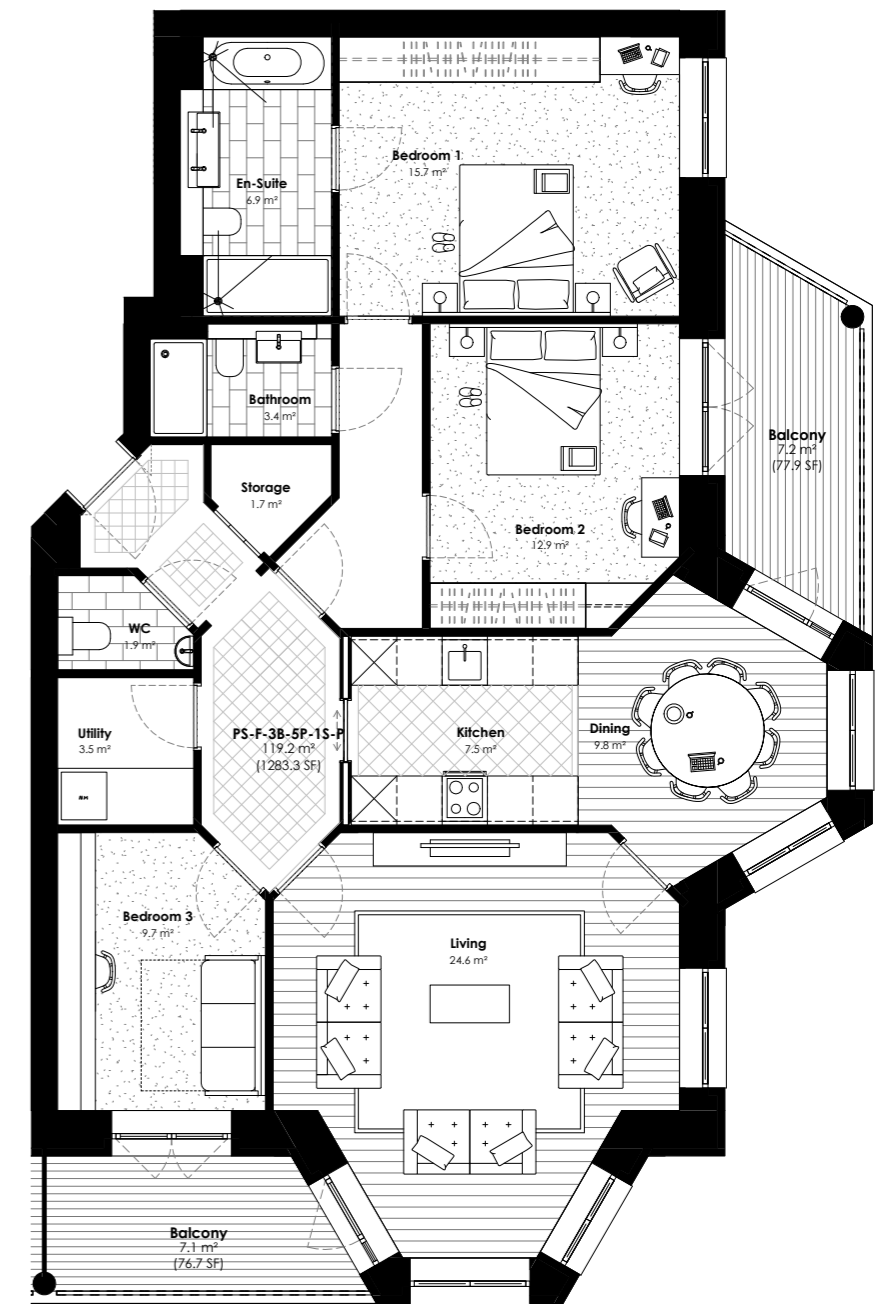



### 8.6.1.2 Building 4.3

Building 4.3 forms the western edge of Canalside Park, where it meets the canal. It is fully residential with a raised ground floor and shares a courtyard garden with building 4.1 (the Tower) and building 4.2. The raised ground floor gives added privacy to the dwellings as well as an excellent outlook over the park and the canal.

The building has a formal entrance from the park at the lower level and has a platform lift within the lobby to allow for level access. As this entrance sits within the park, an alternative route is provided from the lobby of the Tower (building 4.1) via a covered walkway at courtyard level. The core also provides direct access to the basement.

Each living room has a bay balcony offering high quality sheltered amenity. The units to the north have an additional bay and balcony facing the cemetery which also offer views up and down the canal.

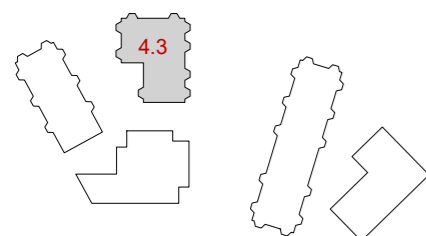

Building 4.3 Typical Upper Plan (Illustrative Scheme)



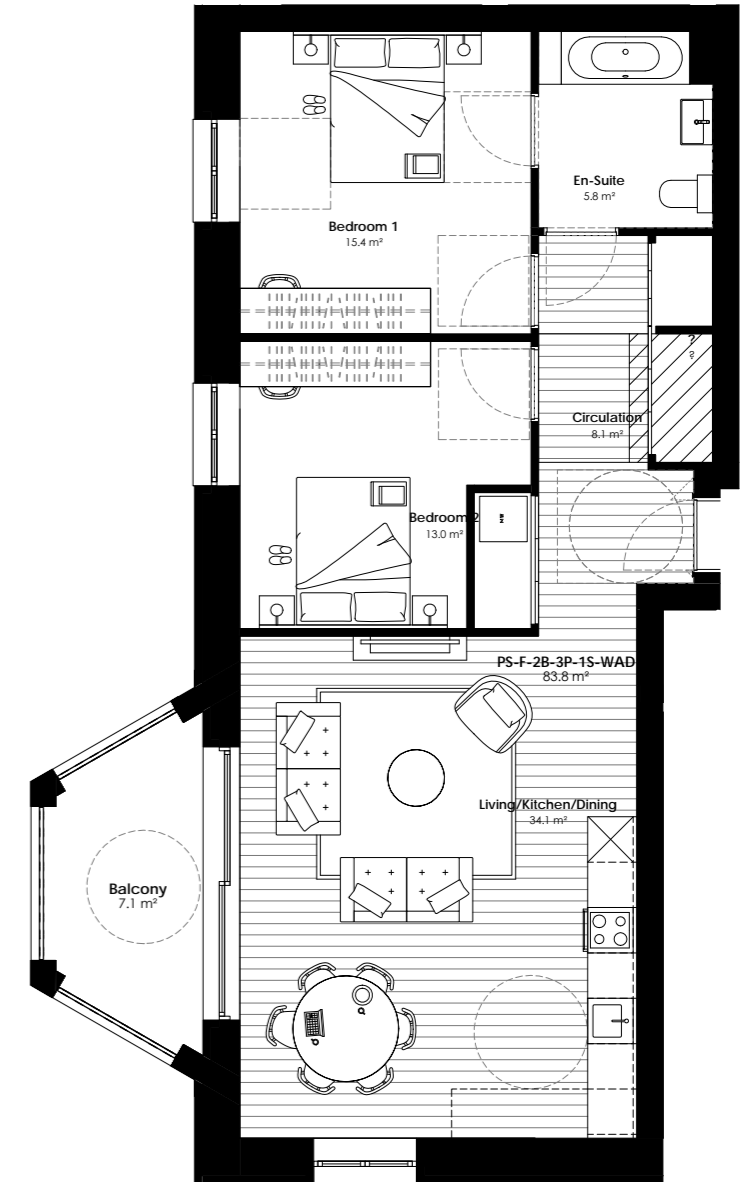

Typical 2 bed 4 person wheelchair adaptable flat in Building 4.3 (Illustrative Scheme)



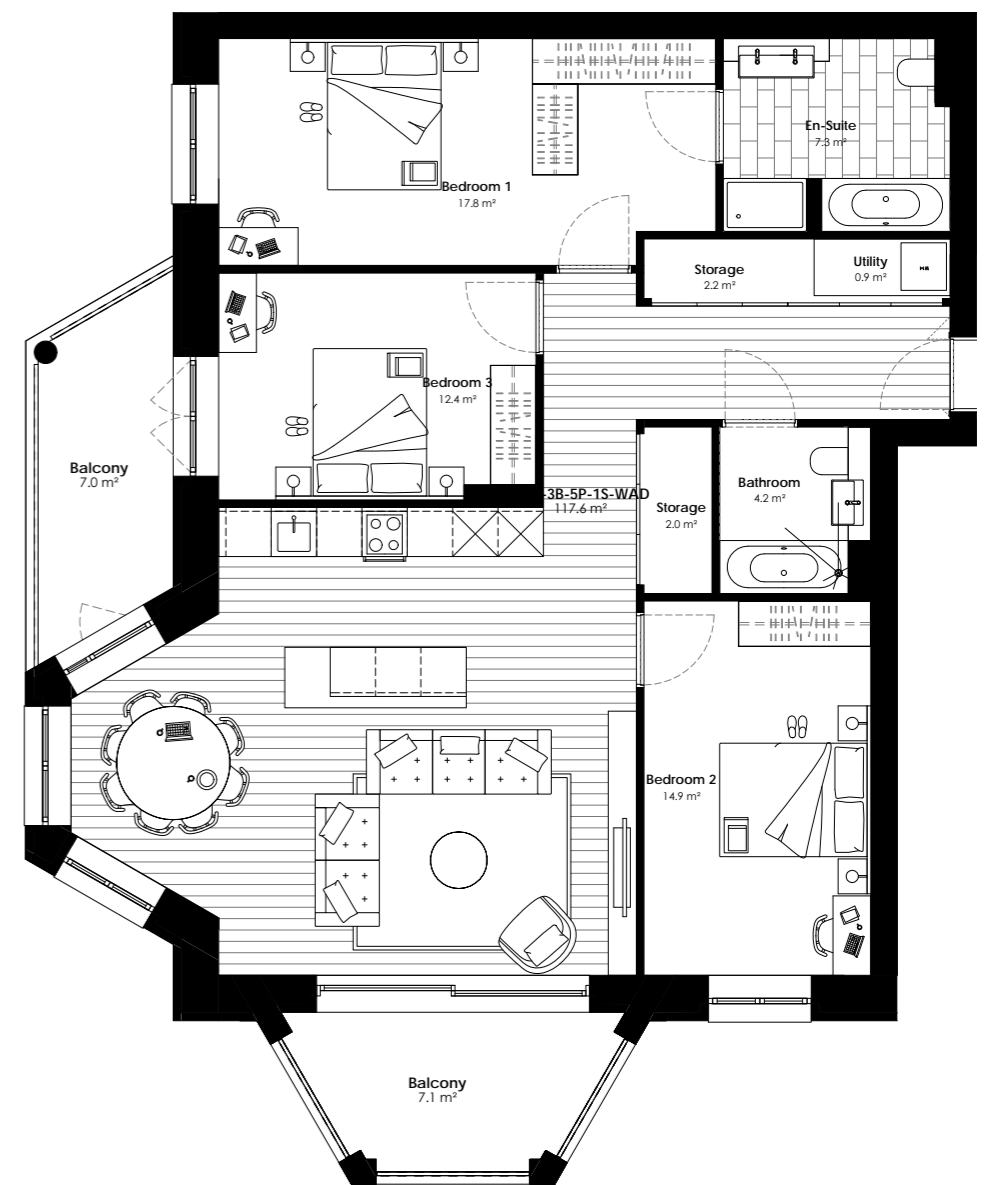

Typical 3 bed 5 person wheelchair adaptable flat in Building 4.3 (Illustrative Scheme)



### Building 4.4

Forming the eastern edge of Canalside Park, building 4.4 is a long mansion block formally addressing the park and spanning all the way from the West Drive to the canal towpath. At its southern end the ground floor is occupied by commercial space which sits directly opposite the entrance to the Sainsbury's store. The rest of the building has a raised ground floor, with dwellings overlooking the park. A communal courtyard sits at the same level as the raised ground floor, allowing level access to the communal garden from the core and giving the raised courtyard exceptional views out across the canal and Kensal Cemetery beyond.

The illustrative scheme has two entrances, a formal entrance facing Canalside Park at lower ground level, and a second entrance from the courtyard side at raised ground level. The larger units are located at each end of the building, benefiting from the corner aspects. There are generous bays to all the living rooms on the typical floors, allowing diagonal views to the canal and maximising opportunities for natural light and ventilation. A balcony sits to the side of each of these bays providing high quality sheltered amenity. The upper two floors are set back, creating fully accessible terraces as the building steps back.

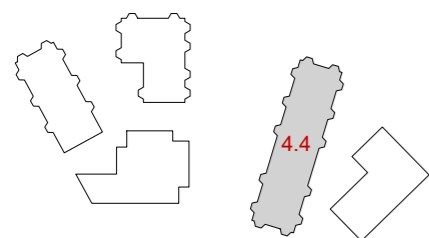
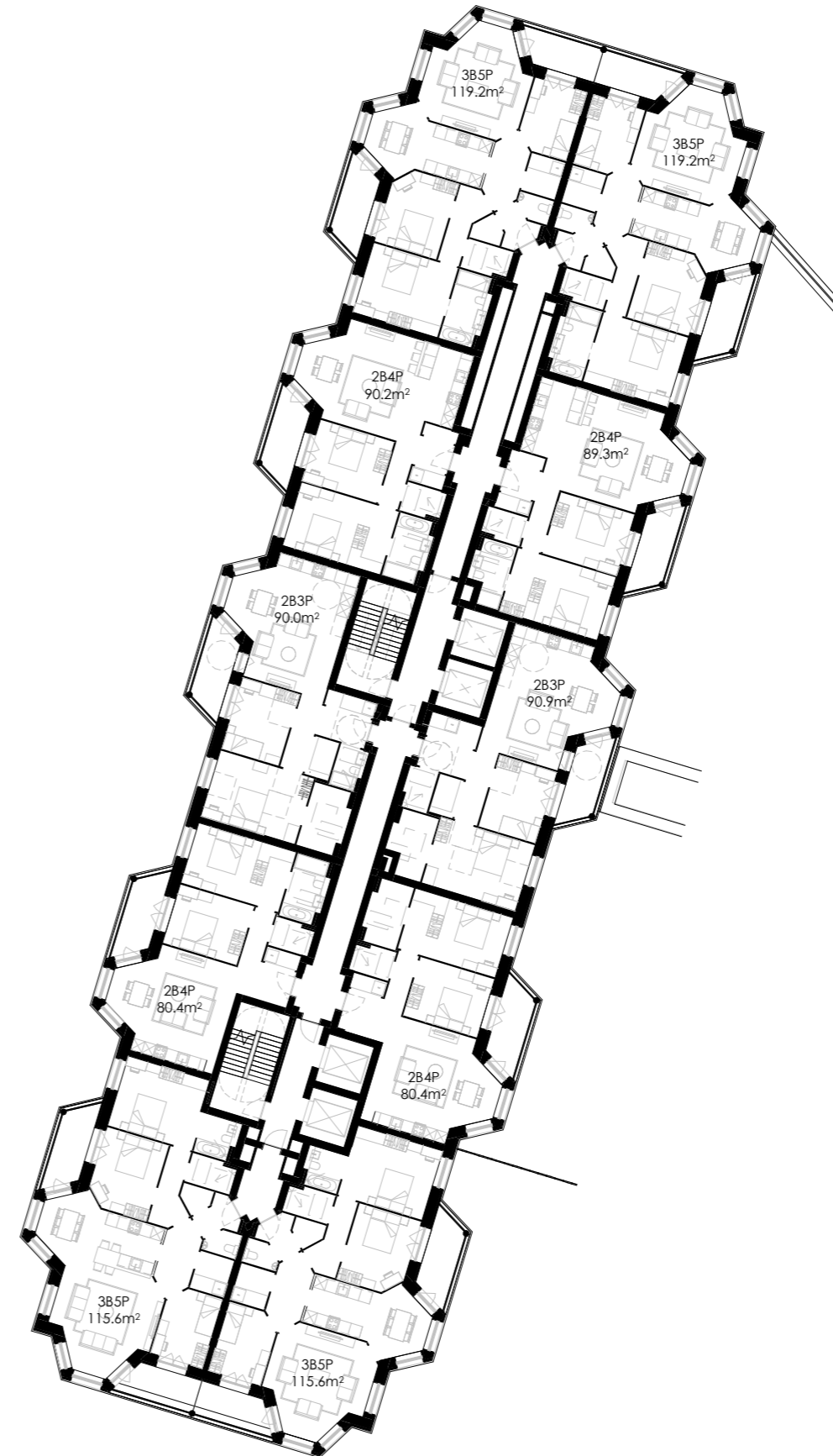

Building 4.4 Typical Upper Plan (Illustrative Scheme)





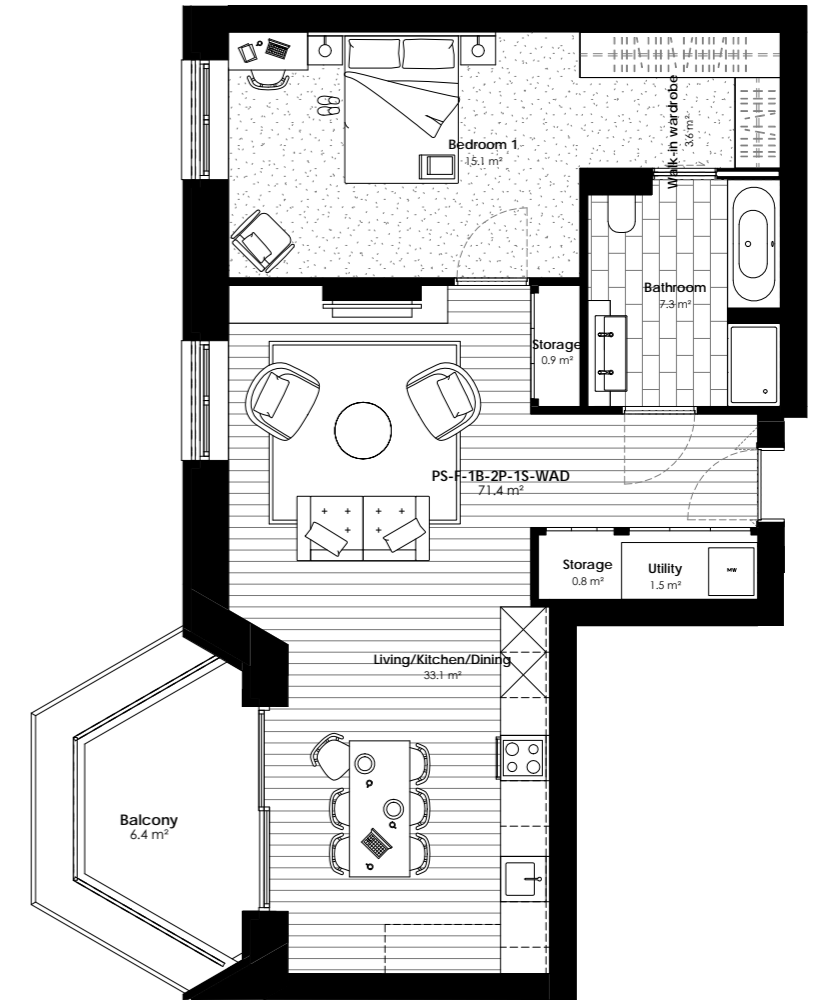

Typical 1 bed 2 person wheelchair adaptable flat in Building 4.2 and 4.4 (Illustrative Scheme)



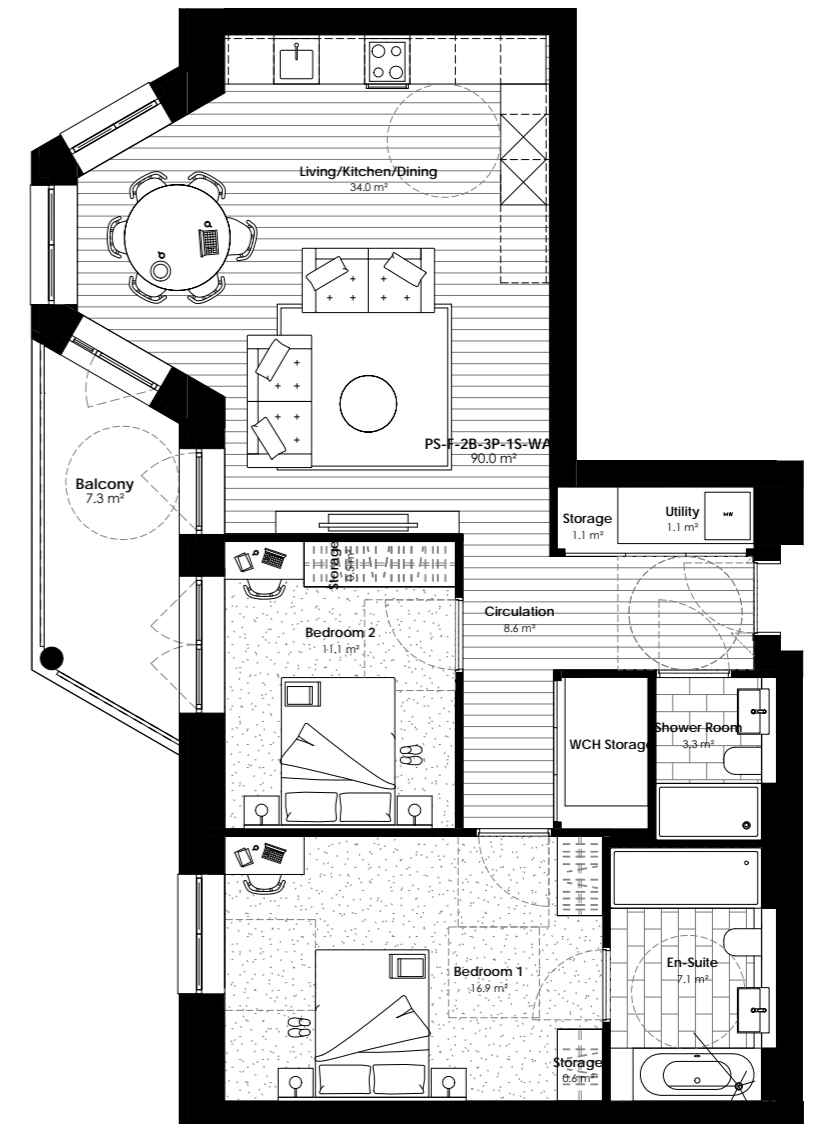



## 8.6.2 Wharf building (4.5)

On the eastern edge of Plot 4, building 4.5 faces the reinstated canal basin. The building forms the transition between the bustling atmosphere of Plot 5 and the more residential character surrounding Canalside Park.

The ground floor facing the basin and canal is occupied by commercial units providing opportunities for cafés bars and restaurants to spill out onto the quayside. The entrance to the residential units that sit above is located on the south-west corner of the building. It faces the West Drive in front of the superstore and runs back along the side of the residential courtyard to the core in the middle of the building.

All the residential units sit in the upper floors and are accessed through a central core. In the illustrative scheme, larger units sit on the corners facing the canal, and all the corner units have double aspect living rooms. Private amenity is provided to each flat in the form of a projecting balcony.

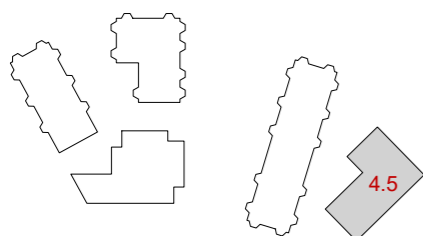
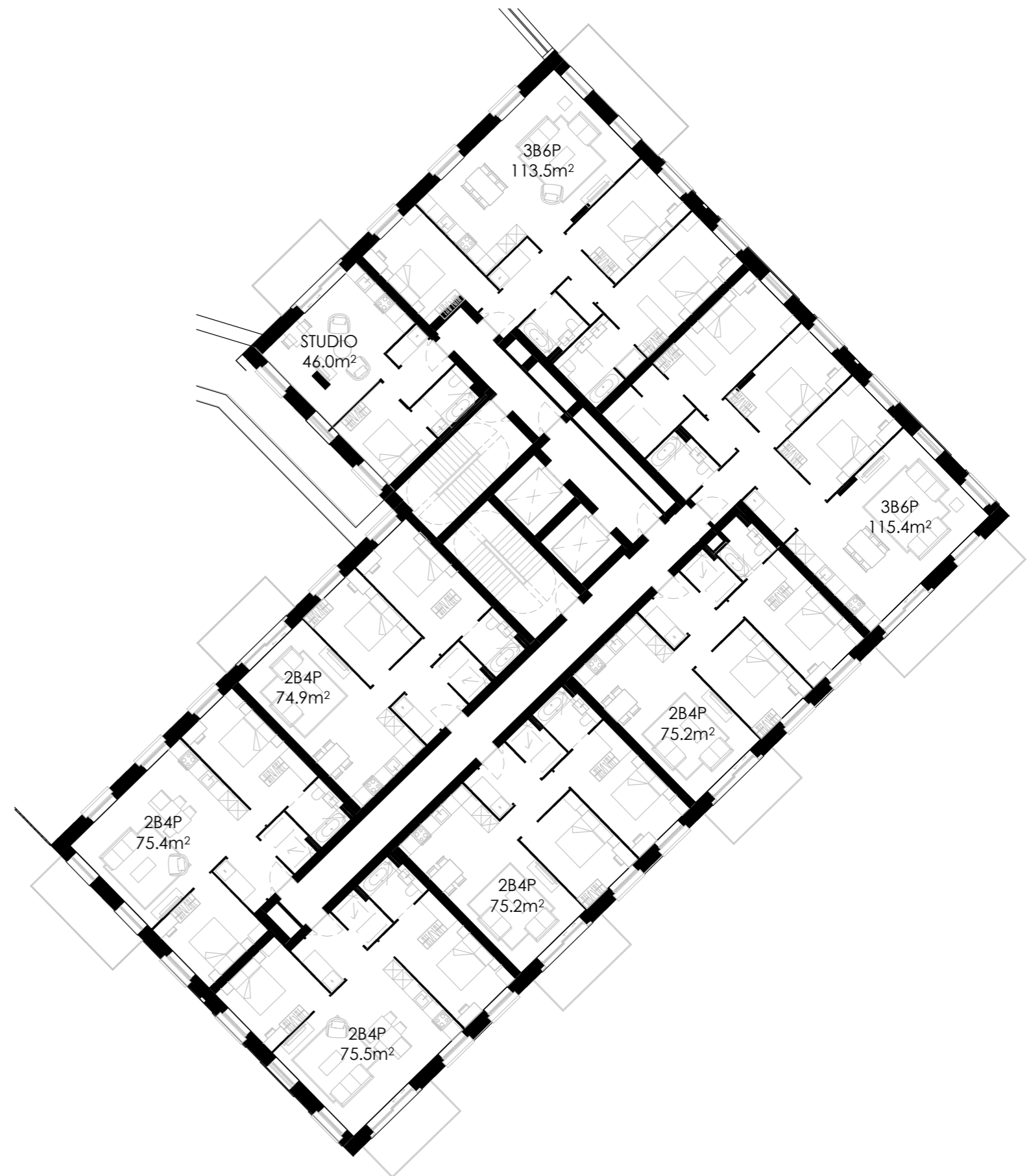

Building 4.5 Typical upper plan (Illustrative Scheme)





Typical 2 bed 4 person flat in the Wharf Building (Illustrative Scheme)



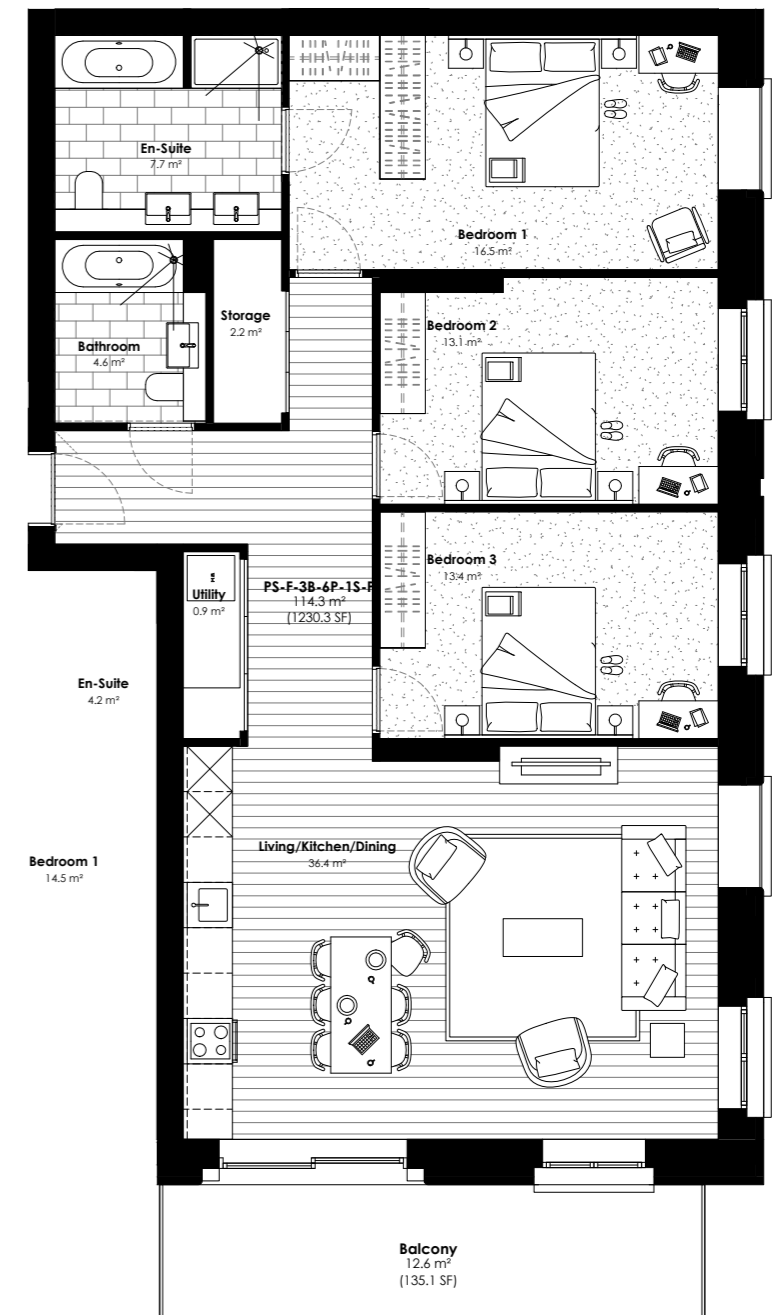



Typical 3 bed 5 person flat in the Wharf Building (Illustrative Scheme)

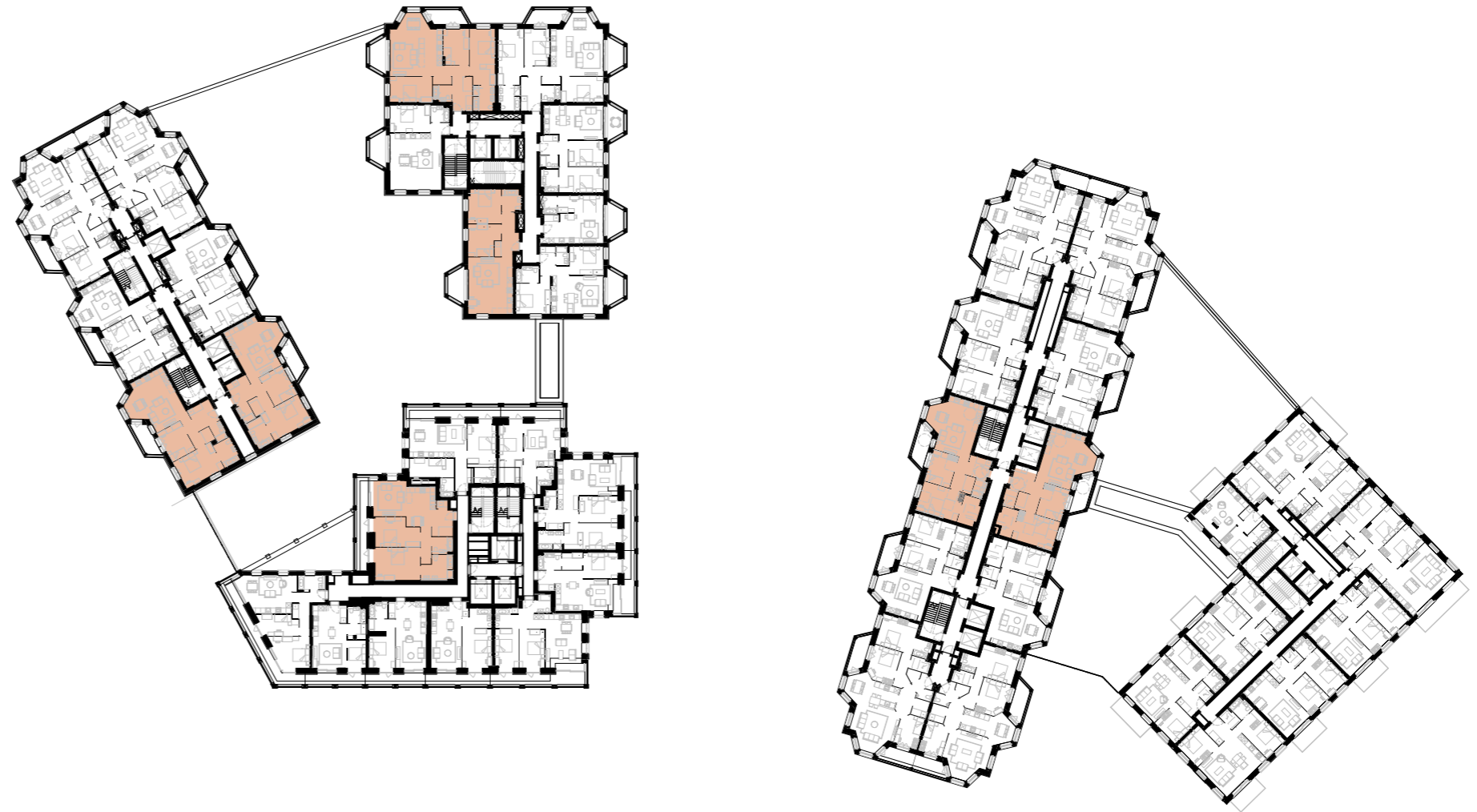

### 8.6.3 Wheelchair adaptable units

Adaptable units will be designed to comply with part M4(3) of the building regulations representing 10% of the overall units. They will offer a variety of apartments sizes and will be distributed across plot 4. This will ensure a range of wheelchair units with a variety of different outlooks and orientations. The accessible units will be designed to the same high quality as the other units within the plot.



 M4(3) 'Adaptable' Units

Typical floor (Indicative locations)





## 8.6.4 Basement and residential parking

This section should be read in conjunction with the detailed Transport Assessment prepared by WSP.

In order to maximise the active frontage at ground floors, a basement is proposed to accommodate all the necessary plant space, cycle storage and vehicular parking required for Plot 4. The basement is composed of two parts. A basement located under the raised courtyard between buildings 4.1, 4.2 and 4.3, which also contains an automated 'stacker' parking system and a smaller section of basement located beneath building 4.4. Due to the proposed relocation of an existing Thames Water sewer between buildings 4.4 and 4.5, the Wharf Block (building 4.5) is not connected directly to the basement. The residents of building 4.5 will access the basement via a covered link that connects the building to the core in building 4.4.

Plot 04 incorporates an automated 'stacker' car parking system accessed from Towpath Mews on the western edge of the plot into plot 4.2. The basement has been designed to accommodate up to 134 parking spaces, all of which are suitable as accessible parking spaces. Residents would drive into a lift containing a 'palette' which would then automatically move the car from the lift to one of the spaces within the basement.

The basement has been designed to ensure it provides sufficient space to incorporate all the necessary plant for the residential and commercial premises except for electrical substations which would need to be located at ground floor level. These will be located in discreet locations to maximise active frontages in key areas.

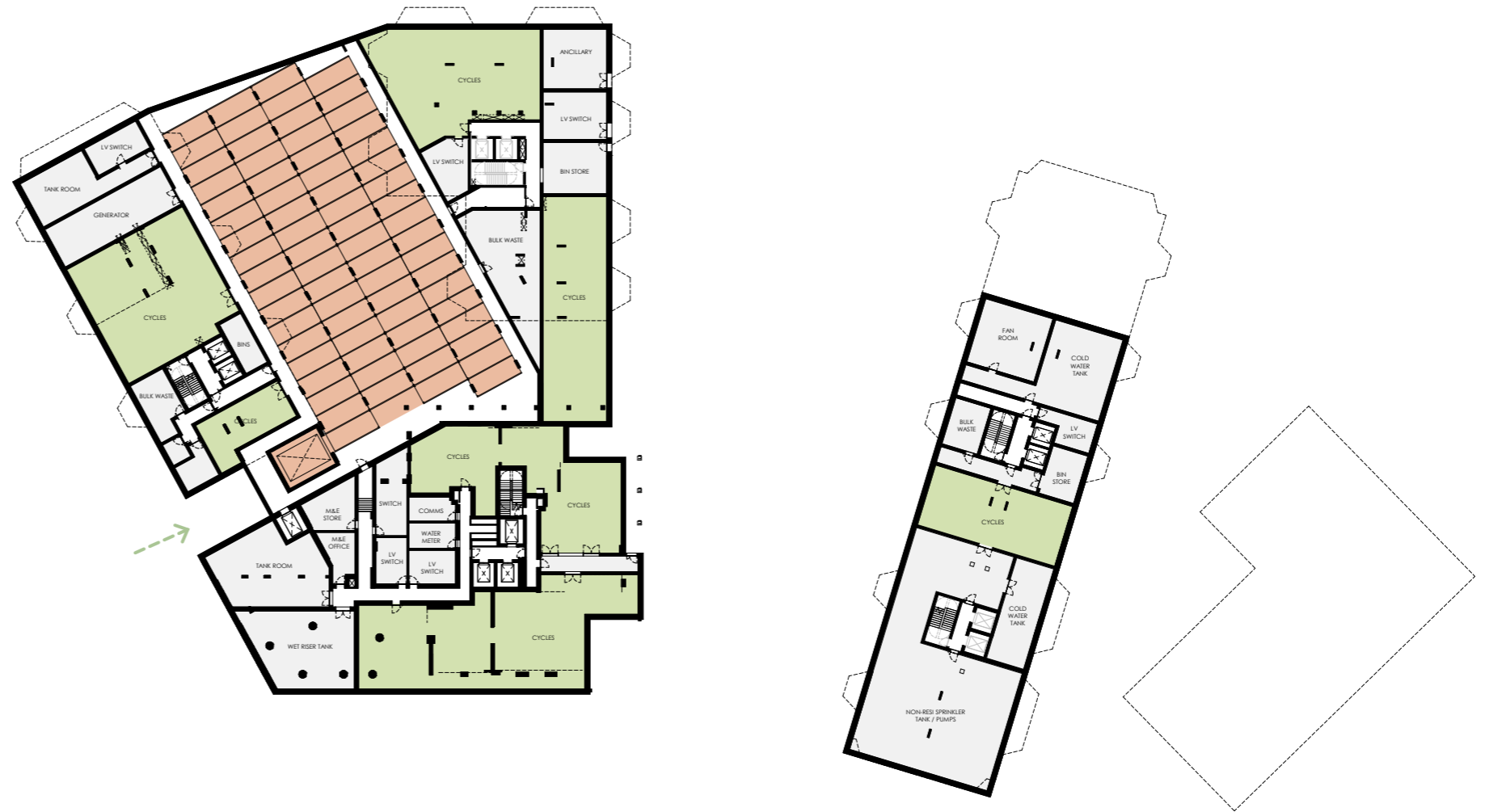

- Plant & Ancillary
- Cycle Stores
- Automated parking and lift
- ← vehicle access route From L00

Basement parking diagram (Illustrative Scheme)





# 8.7 Appearance

## 8.7.1 Plot 4

Plot 4 sits at a strategic point in the Masterplan, where the canal to the north curves and the geometry of the masterplan shifts from a grand central boulevard to a neighbourhood-scale series of streets. This is also the point at which the character changes from a busy high street to the East, with commercial ground floors and active frontage lining the approach from Ladbroke Grove, to the quieter and more residential character to the West. The proposals for Plot 4 aim to reinforce this character and help to enable this transition.

Of the five buildings on Plot 4, there are three building types. In order as one approaches from the East, these are: a wharf building, then three mansion blocks that define public and semi-private gardens, and finally the tower. With the exception of the tower, a type for which there are fewer established precedents historically, the buildings borrow certain reference points from understood and familiar London building types. The intention is not merely to borrow architectural language from a bygone era in order to lend authenticity to this new development, but to make contemporary buildings with subtle accents that feel appropriate to their place. A Design Code will be submitted as part the application with the 'Mandatory' elements being conditioned. This will secure key elements of the design within the approval.

The wharf building (Building 4.5) has a distinctive upright, pitch-roofed form redolent of post-industrial revolution dockside warehouse buildings found across London, found along both rivers and canals.

The mansion blocks (Buildings 4.2, 4.3 and 4.4) recall the genteel red and white residences of West London, such as in Maida Vale and Marylebone, and help to define the domestic character of the park and gardens.

The tower (Building 4.1) sits at the heart of the masterplan and marks the change of orientation of the avenue. It is similarly comprised of masonry and distinctly architectural details and so sits comfortably alongside the mansion blocks, but its overall expression is more abstract. Being read 'in



View looking West toward Plot 4 along the central Avenue



## 8.7.2 Materiality

Beyond allusions to historical contextual architecture, the proposed buildings for Plot 4 draw much of their weight and decorum from their material construction. High quality brick is used throughout, articulated by artificial stone or precast elements that echo the fine grain of their precedents but with a sheerer and more contemporary approach to detail.

Consideration has been given to the colour and texture of the materials in the context of the wider masterplan, to offer a distinct but complementary palette. Across Plot 4 also these colours transition, both to strengthen the idea of a move from civic to residential character, and to sit comfortably with neighbouring buildings. The Wharf Block (building 4.5) is intended to echo old industrial warehouses and the adjacent canal bridge that permits access to the new basin directly in front of the building.





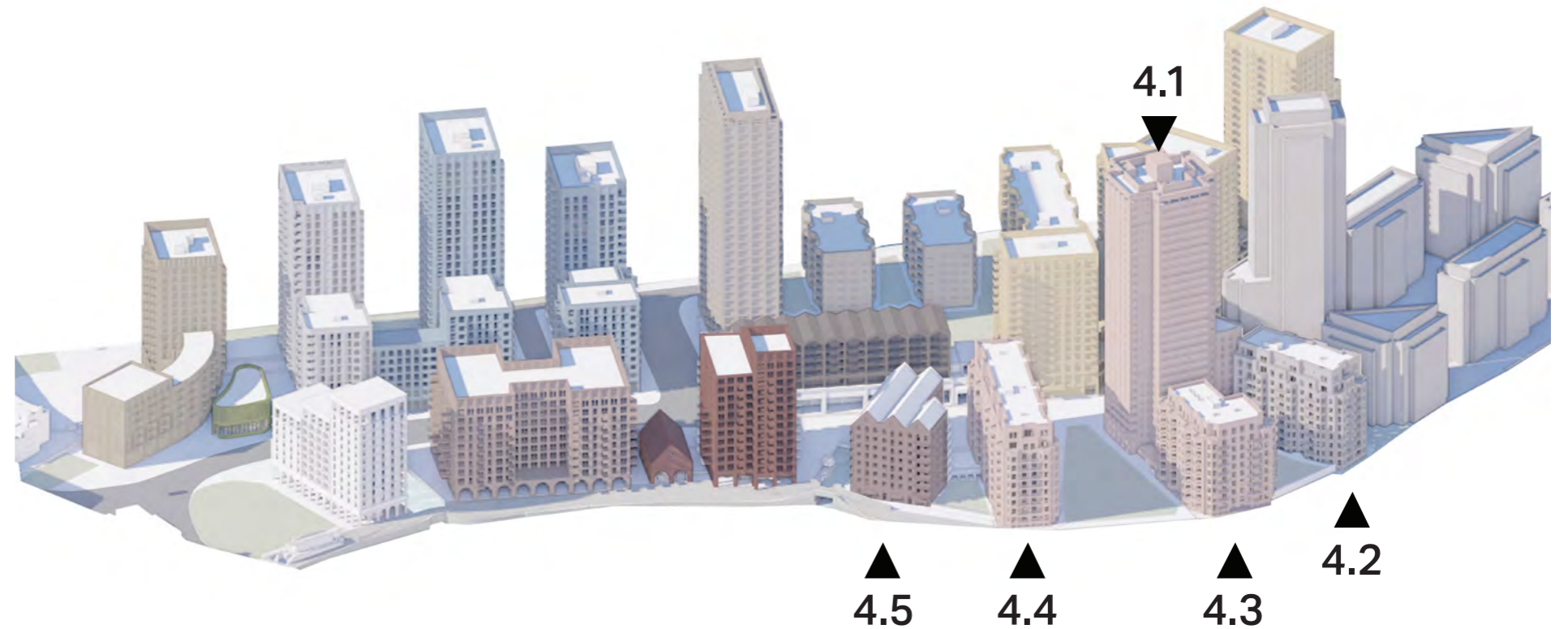









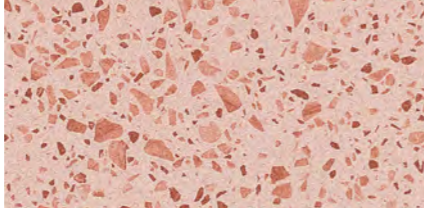
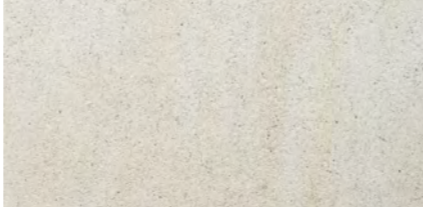

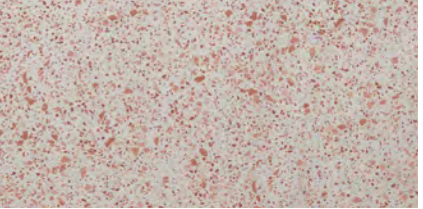
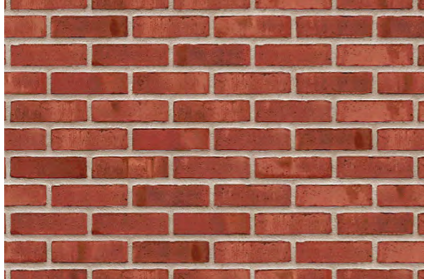

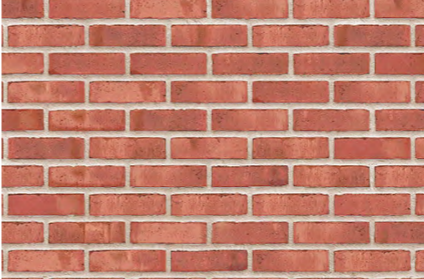
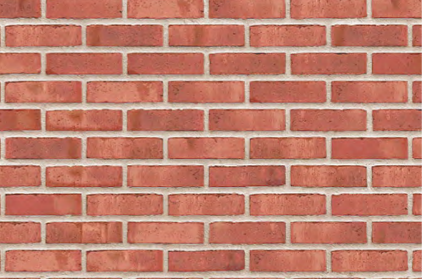
The Mansion Blocks (buildings 4.2, 4.3 and 4.4) playfully reference the familiar flamboyant red and white striped Victorian mansion blocks that are found across London but particularly in the west of the city. In combination with their language of bay windows and masonry banding, the character here is much more residential yet grand and provides a convivial backdrop to the green of the park. An exception to this is building 4.2, which has the same architecture but a softer tone to give variety and signal the transition to Plot 03.

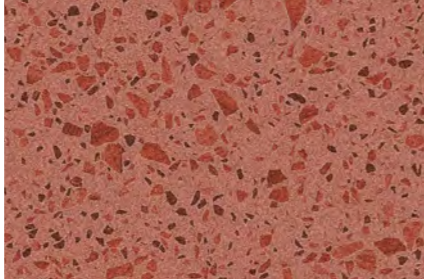
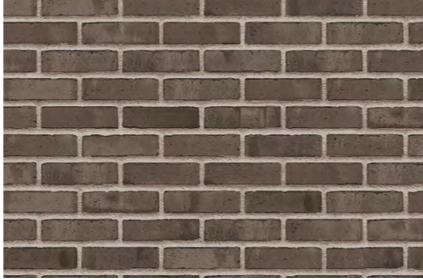
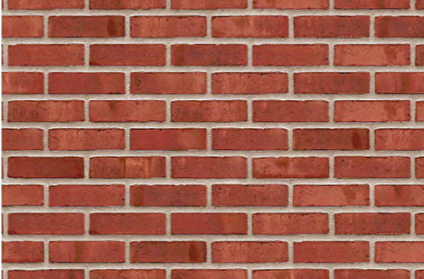
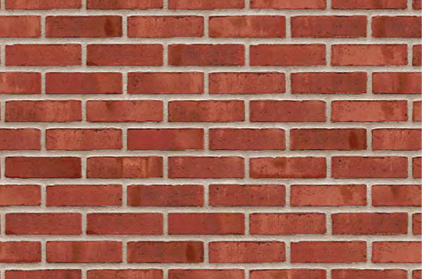
Also located at the edge of the park is the Tower (building 4.1), which will have a similar tone as buildings 4.3 and 4.4 but expressed in a more contemporary way as an overall colouring. Within the illustrative scheme, red brick is used between the distinctive stacks of loggias that comprise each of its four sides, which themselves would be delivered in a lighter tone of masonry. At the lower levels of this building, in common with the mansion blocks, the colour is darker and richer to express a base.

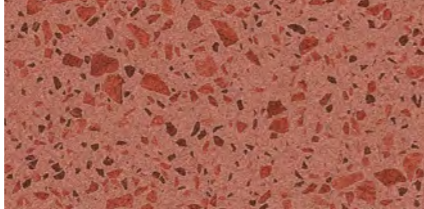

Plot 4 building colours in context aerial

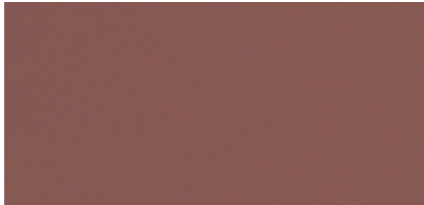
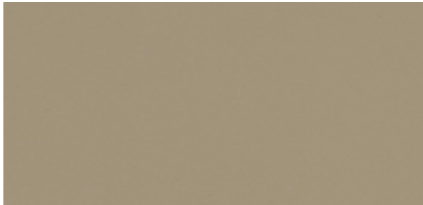
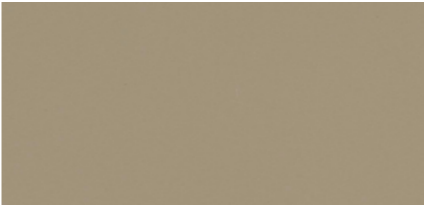

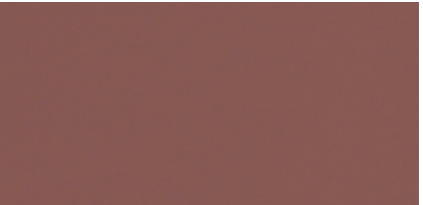
	Building 4.1	Building 4.2	Building 4.3	Building 4.4	Building 4.5
Stripes and reveals					
Precast accents					
Main Body Material					
Plinth Material					
Plinth Accent					
Metalwork and render					

Plot 4 Illustrative material palette showing complementary approach to texture and tone.



### 8.7.3 The Tower Building (4.1)

The Tower (building 4.1), is conceived in the masterplan as a fulcrum, marking a change in orientation in the urban grain. It is located at the bend in the central avenue, at a point from which several buildings 'fan out' radially to respond to the curvature of the canal to the north. Furthermore, it signposts the location of the public park at its base, which is in turn framed by buildings 4.3 and 4.4. It also works together with the tall building in Plot 3 (the St William site) to signify the start of the pedestrian route to the potential bridge link across the canal at the start of West Drive.

The building itself will have a relaxed symmetry owing to its offset 'pinwheel' plan, as opposed to a pure cruciform plan. Each of the four wings will be fronted by a dramatic stack of continuous loggia balconies, their openness contrasting with the solidity of the connecting brickwork between them.

Like the Mansion Blocks too, the tower will have a darker base with a slightly modified order that allows the retail and lobby frontages to extend to the outer line of the loggias above, giving the base a more solid appearance. At its top, the tower culminates with a taller floor and correspondingly more significant loggia. The extruded tower form ends confidently to preserve its legibility in the skyline.

While the upper part of the tower will be necessarily read 'in the round' and therefore have no front or back, the lower eight floors of the building's gridded facade extend to respond to the street and wrap around to create a corner of appropriate urban scale. This 'shoulder' height reiterates the datum created by the adjacent Mansion Blocks.

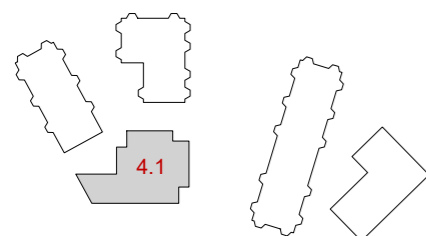

View looking West toward Plot 4 along the central Avenue





Sketch showing the relationship of the Building 4.1 with the park and Avenue



Where the lower buildings for Plot 4 look to historical precedents to lend their architecture a particular character, the tower does not. This is partly because there are few relevant historical examples to draw from other than Twentieth Century modernist towers, and because its role as a tower suggests that it should be a simple and readily understood form, in this case a highly legible extruded four-sided geometric object.

That said, the building has a definite load-bearing 'architectural' language apparent at close quarters and from afar. Unusually for a building of this height, the architecture has a heavy masonry aesthetic. This is in large part due to the loggia stacks, which sit assertively at each side. The order here speaks of traditional post-and-beam, with an interplay of vertical and horizontal elements providing relief but also an even overall gridded surface. Balustrades here are glass, to give priority visually to the stone and to offer protection from the wind at height, with a minimal metal cap forming the handrail. The internal spaces of the loggias, each of which is shared between a 1-bed and a 2-bed apartment and subdivided by a privacy screen, has a tinted rendered rear wall and soffit and paving colour-matched to the structure.

Of particular note are the corner windows. Providing impressive views diagonally out of the apartments, they also allow for a wider opening at the ends of the loggias than would otherwise be possible. Between the loggia stacks, relatively plain inner corners have simple portrait orientation windows that emphasise the vertical. While the loggias will inherently frame horizontal panoramic views out, these windows offer views up and down. They will have colour-matched sills to add further quietness to these intentionally secondary joining elements.

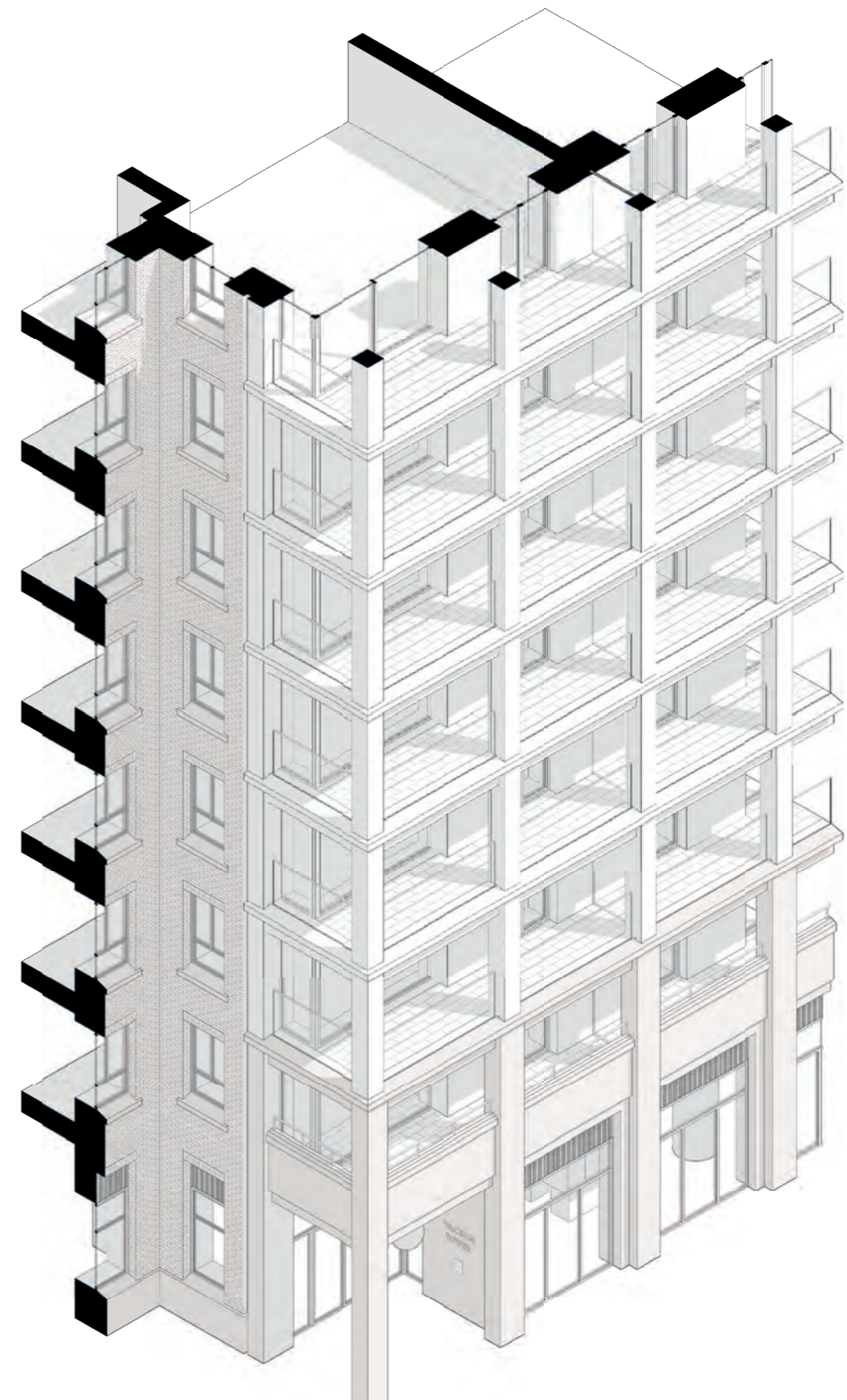
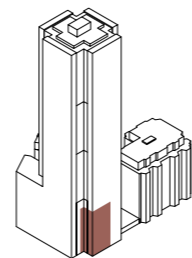

Axonometric bay study of lower tower (Illustrative Scheme)



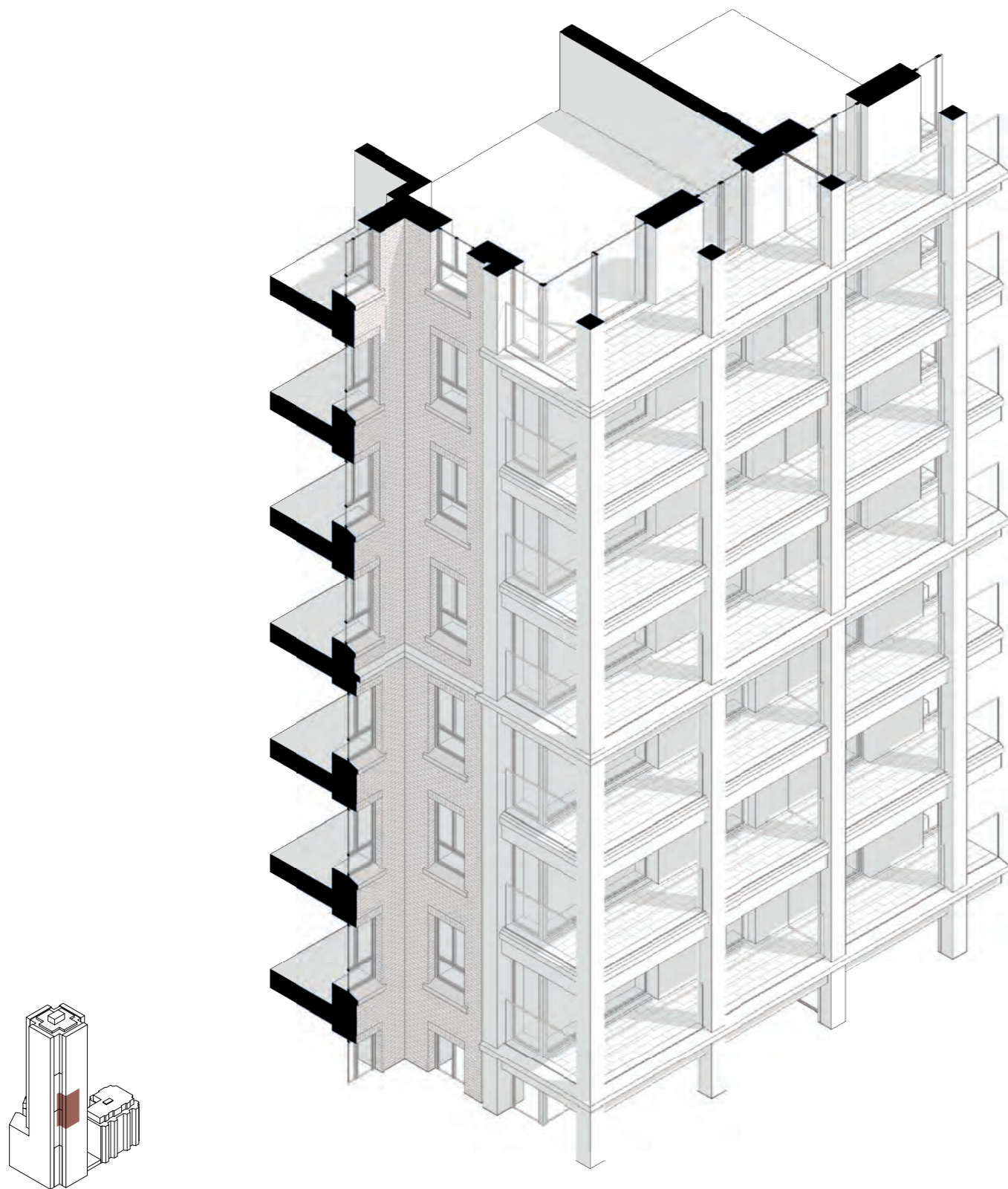

Axonometric bay study of mid-section of tower (Illustrative Scheme)

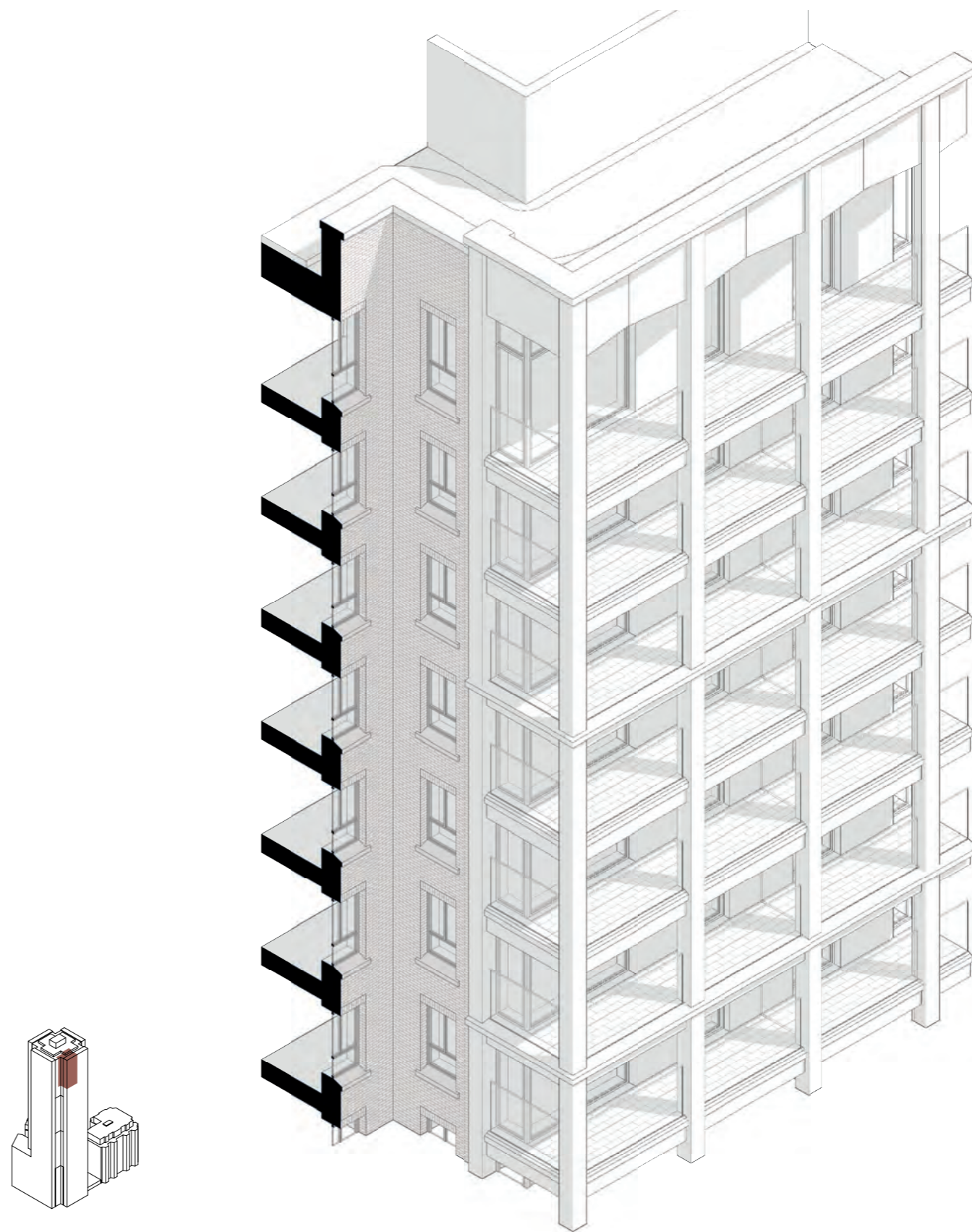

Axonometric bay study of upper tower (Illustrative Scheme)



Within the rigour and repetition of the Tower's design is a significant level of variation and richness. The overall height is divided into four quarters that convey the shift in loading of the superstructure. As the tower rises and the required structure becomes thinner, the inset corners step in, further accentuating the contrast with the loggias, and window reveals become shallower. Similarly, every third loggia has a deeper stringer that sits proud of the columns, grouping the floors into groups of three and thereby accentuating the vertical.

The base of the building is more solid as the glazing line steps out and columns thicken to create retail and lobby frontages, while first floor loggias are given an upstand to give privacy and also visual separation between commercial and residential openings.

The Tower employs several tones of the same colour to give the building the homogenous quality of a single object. Brickwork and masonry would be used in a complementary colour palette to reinforce this idea and naturally transition between the base and upper levels of the building.



View of the top of the tower



Residential entrance



Ground floor commercial units





Sketch of the top of building 4.1

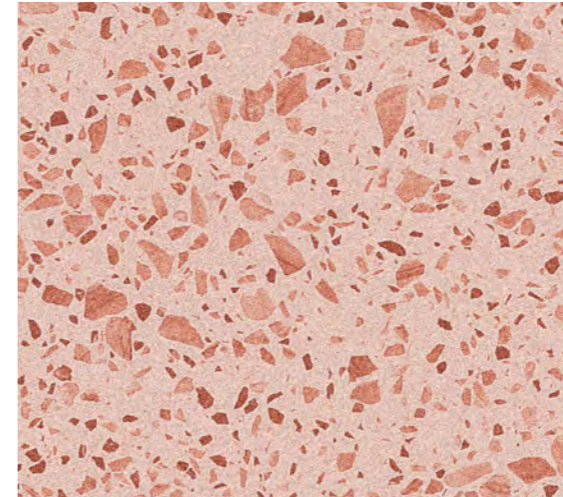

Light pinkish-red reconstituted stone with red granite aggregate

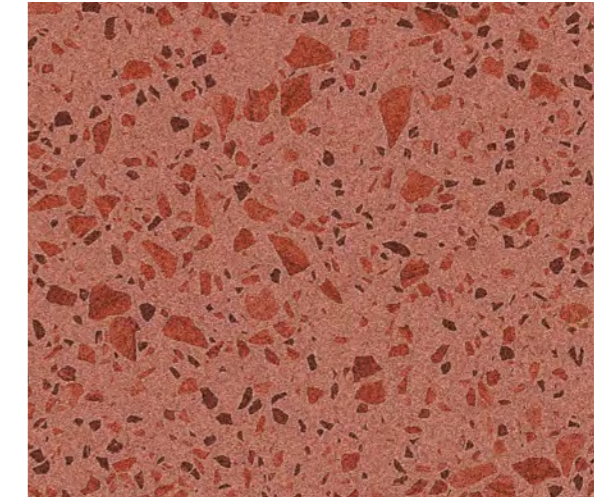

Darker red pigmented reconstituted stone with red granite aggregate

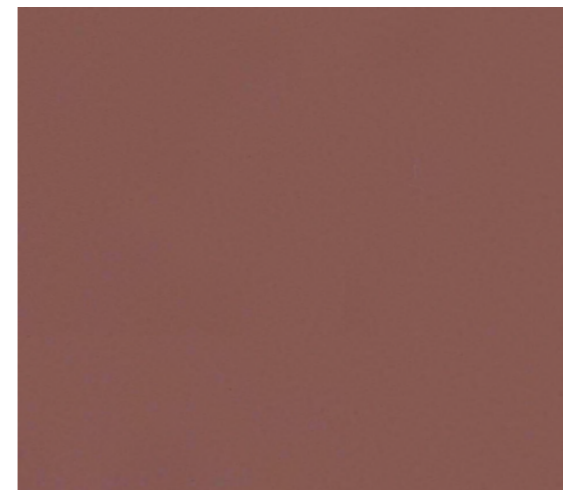

Dull maroon coloured render to balcony linings



Red water-struck bricks



Dull maroon metalwork and balcony lining



### 8.7.4 The Mansion Blocks (4.2, 4.3 and 4.4)

The Mansion Blocks (Buildings 4.2, 4.3 and 4.4) are in a way the substance of Plot 4, even though they do not have the density or visual reach of the Tower. They define edges to the park, to gardens and to streets, and their exuberant character sets a particular tone across the plot. The three buildings have been designed to incorporate both obvious and subtle differences between them but share many details and a common aesthetic. This aesthetic is derived from predominantly Nineteenth Century West London mansion blocks, many of which are built in a rich red brick and feature a profusion of detail and decoration.

The proposed blocks are a contemporary interpretation of these precedents. Crucially, where the historical precedent would typically have a distinct front and back, the proposed buildings do not and are essentially symmetrical around their central corridors. This is necessary as they are not simply fronting streets but in spanning north-to-south between the canal and West Drive they help define the edges of the Park and courtyard gardens and are thus viewed from all sides equally.

The facades of buildings are characterised by their bay windows which have the benefit of offering wide views and ample daylight but they also provide an undulating rhythm evocative of so many residential neighbourhoods in London.

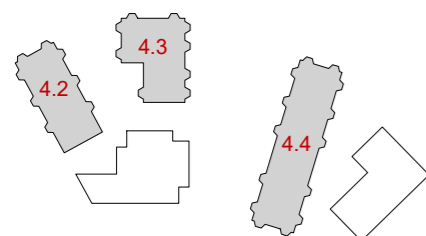

View looking East toward Building 4.4 from across the canal





Sketch showing the relationship of Building 4.2 to its courtyard garden and the canal



Sketch showing the relationship of Building 4.3 to the park and canal



Despite the appearance of complexity, the mansion blocks utilise many repeated unit layouts and a common approach to circulation cores. The uppermost two levels are comprised in the illustrative scheme of larger homes and, outwardly, a language of dormers and terraces that gives a somewhat celebratory roofline.

Stringers are used to create horizontal bands to accentuate the highly modelled facades of bays and dormers. These correspond with the floor slabs and project outwards to make elegant balconies adjacent to the bay windows (on Buildings 4.2 and 4.4). A simple round column provides support to these and heightens the sense of them being delicate assemblies distinct from the heavy masonry elsewhere.

Perhaps the most distinctive element of the appearance of the mansion blocks is the striped brickwork 'quoins'. These are derived directly from the historic precedent, which in turn were a decorative approximation of stone quoining. Traditionally, quoins are blocks of stone used to strengthen corners and subsequently as a decorative accent, as such these were a common feature of the so-called 'Queen Anne' style of baroque English architecture. In the proposal, these stripes are purely decorative and their rigour more like a pattern than an allusion to structural necessity. They are used primarily to accent the stacks of bay windows and bay balconies, to group them vertically, while the plainer walls between them have only the continuous reconstituted stone stringer once per level.



Example of Quoins within illustrative scheme)

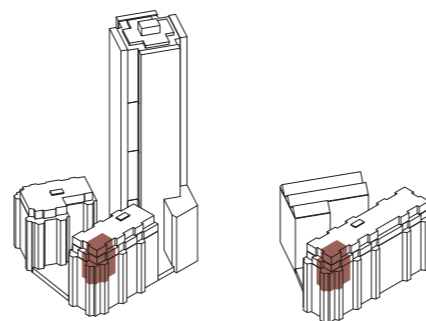

Axonometric bay study of upper corner of Buildings 4.2 and 4.4 (Illustrative Scheme)



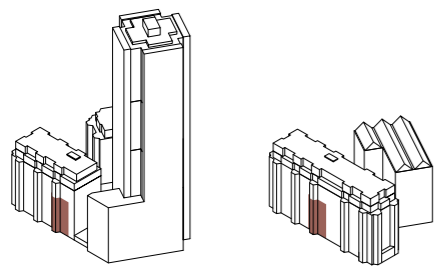
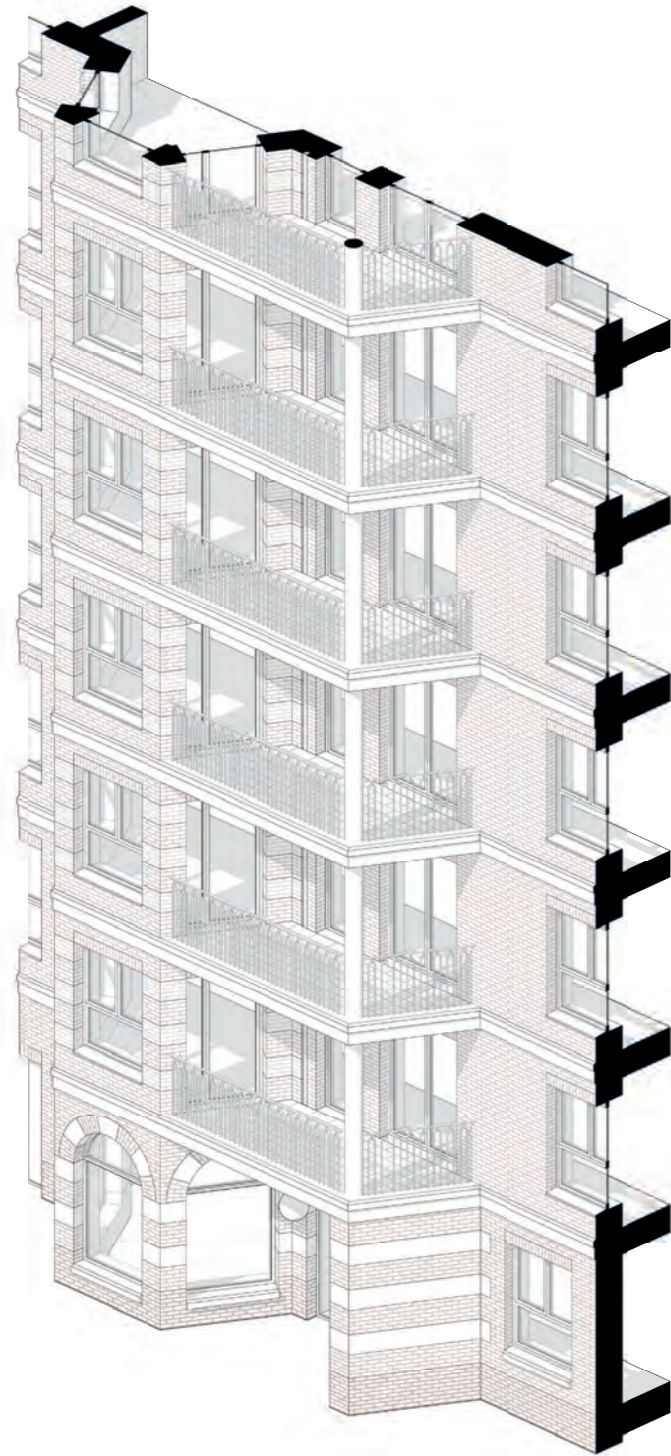

Axonometric bay study of lower portion of Buildings 4.2 and 4.4, including entrance (Illustrative Scheme)

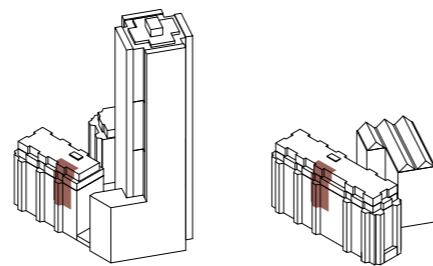
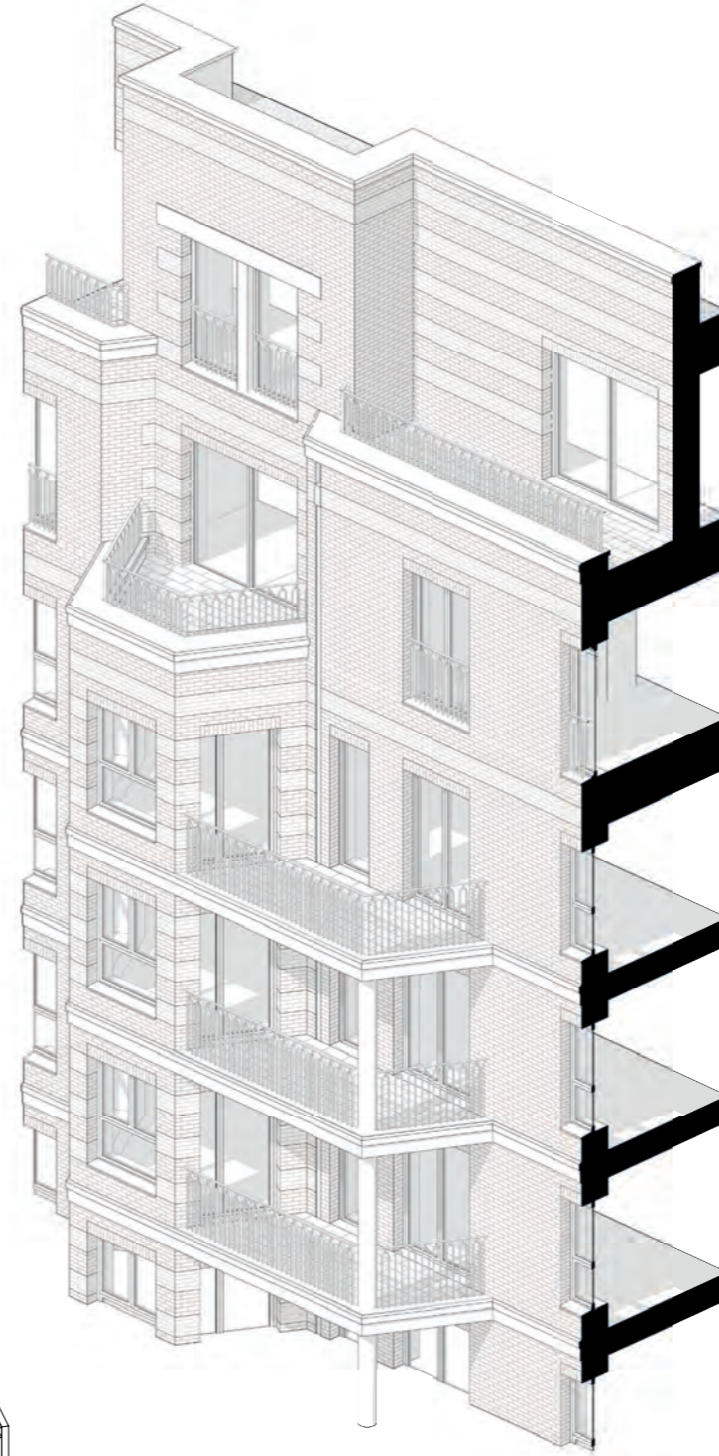

Axonometric bay study of upper portion of Buildings 4.2 and 4.4 (Illustrative Scheme)

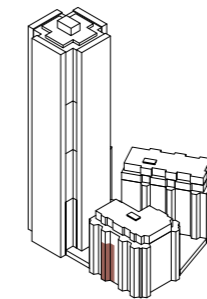
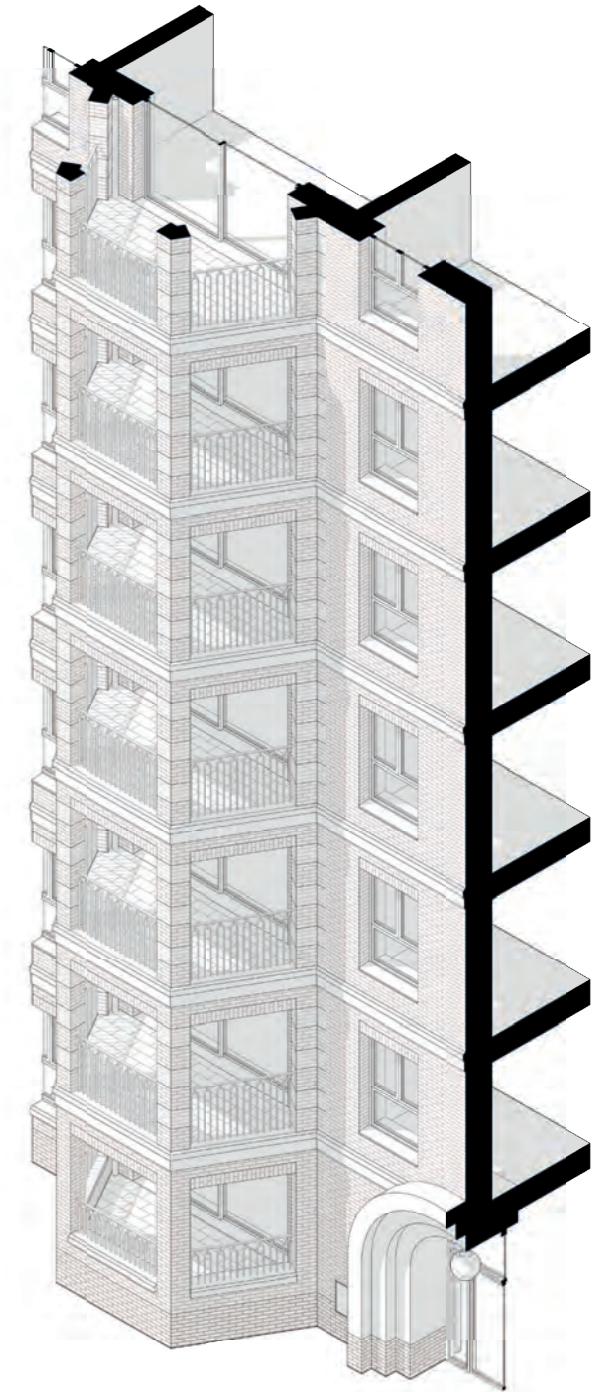

Axonometric bay study of lower portion of Buildings 4.3, including entrance (Illustrative Scheme)



True to the historical precedent, the entrances to the mansion blocks are celebrated. Enhancing their presence is also important as they are located along the Park or Towpath Mews and need to be easily located when arriving from West Drive. Within the illustrative proposals, building entrances have been clearly articulated to give prominence from the street and at ground floor a landscape buffer has been provided to create separation from the main pedestrian thoroughfares.

Shown below and opposite are the typical bay window with balcony and bay balcony (Building 4.3) conditions. You can see how the evenly spaced stripes correspond with all openings. The decorative balustrades with their distinctive half-round echo the arches that appear at the entrances below.



Building 4.3 residential entrance



Building 4.3 typical bay balcony





Building 4.4 residential entrance



Building 4.2 courtyard entrance



Building 4.2 typical bay window and balcony



Building 4.4 typical bay window and balcon



The buildings are set out to appear ordered and harmonious. Commercial units have been positioned to frame the main street, West Drive' which runs in an east to west orientation here in front of the proposed Sainsbury's Store main entrance.

Within the illustrative scheme a combination of textured bricks has been employed to articulate areas of the facade. in greater detail. Contrasting brick and masonry have been used to signal the transition between the commercial units at ground floor and the residential units above.



Building 4.4 penthouse level terraced roofscape



Building 4.4 commercial unit





Grey water-struck bricks



White water-struck bricks



Red water-struck bricks



White water-struck bricks



Dark grey water-struck bricks



Dark grey glazed bricks



Dark red water-struck bricks



Dark red glazed bricks



Sandy light grey reconstituted stone



'Khaki' metalwork



Sandy light grey reconstituted stone



'Khaki' metalwork



## 8.7.5 The Wharf Building (4.5)

The wharf building sits on a corner between the canal and the re-established basin, fronting water on its two longest sides. It is the first building on Plot 4 to be seen when approaching from The Avenue to the east. The block has an L-shaped plan but can be understood as three adjoined volumes, each with a pitched roof. These roofs and the buildings upright proportions immediately bring to mind the historic warehouse and industrial buildings often situated, for reasons of transportation of materials and goods, alongside waterways, hence the use of the term wharf. The detail and materials here are correspondingly muted.

In keeping with this reference point, Building 4.5 is, at first glance, relatively unadorned with decoration compared with the mansion blocks. However, within the rather sober language are several moments of extra detail that add richness and complexity.

The illustrative scheme and parameter models contain gable ends at the northern canal end and the southern end facing West Drive. These are visually split by recessed 'shadow gaps' to heighten the sense of a conglomerate building with pragmatic, repeated facades and create a vertical emphasis. Juliet balconies recall old warehouse buildings which historically allowed cranes in and out. At the top of each gable is a louvered opening that provides ventilation to the attic space but also recalls the precedent.



View looking West toward Plot 4 along the central Avenue



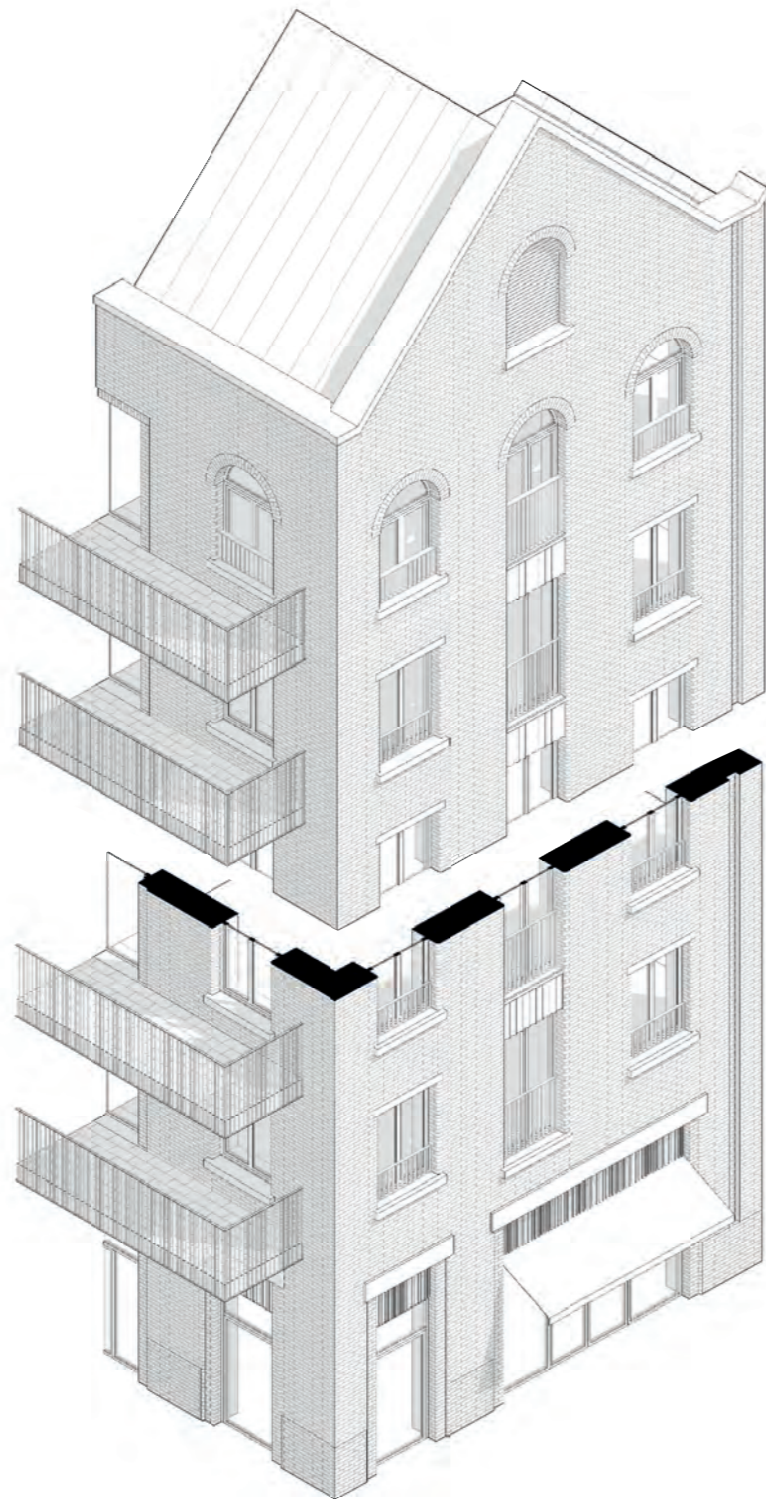

Axonometric bay study of Building 4.5 gable (Illustrative Scheme)

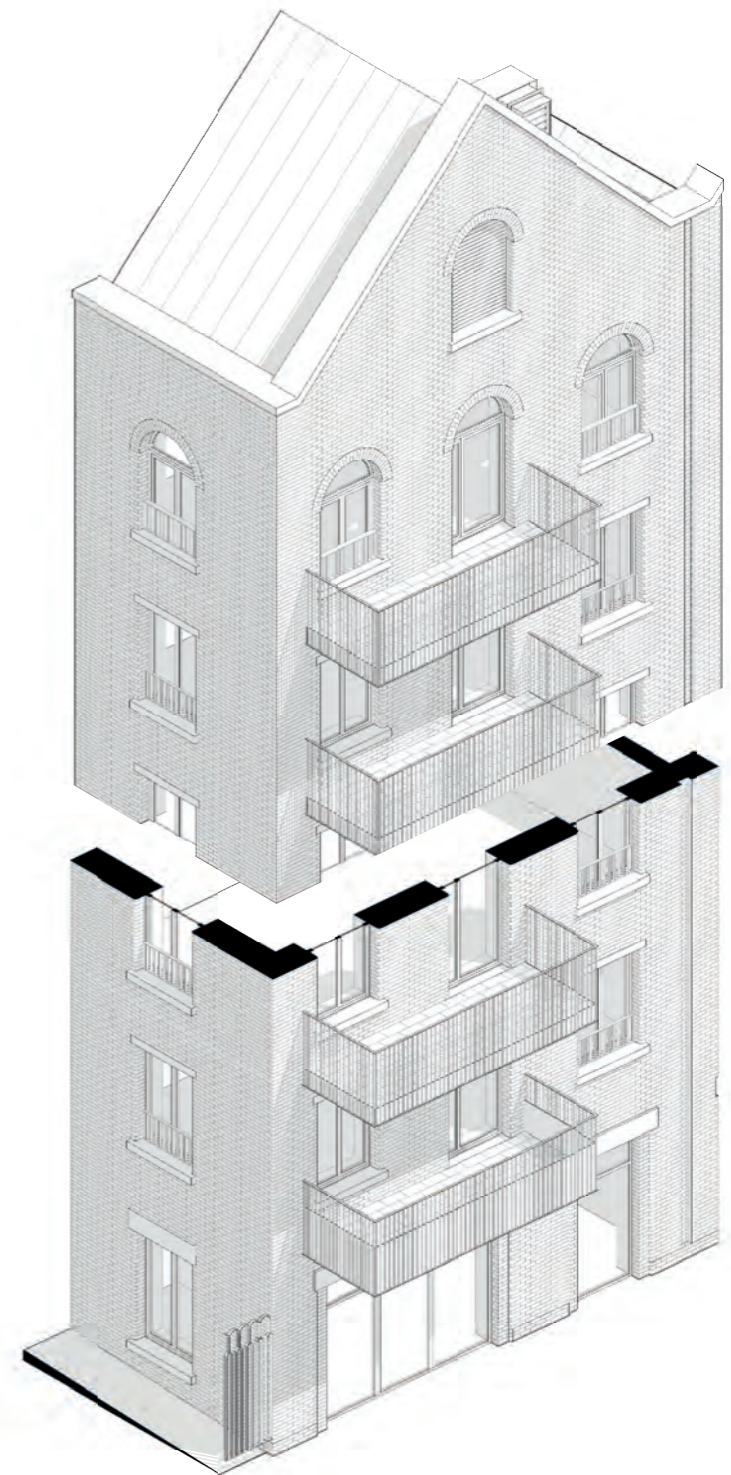

Axonometric bay study of Building 4.5 entrance (Illustrative Scheme)



The side elevations, the eastern one of which could in fact be said to be the main façade, continue these details but with the addition of large projecting balconies. The design of these is intentionally rudimentary, compared with the pomp of the mansion blocks, to again fit with the block's industrial character. The pitched roofs are set back behind parapets with a concealed gutter and an appropriately substantial coping.

The identity of this building is inextricable from the quayside it addresses. The ground floor is predominantly commercial space that will enliven this public space, with large glazed openings of alternating width relating to the fenestration above. Above awnings, ventilation panels that reiterate the metalwork of the balconies provide a signage zone.



Quayside with commercial units

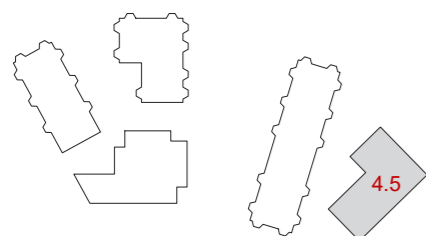

Typical side elevation

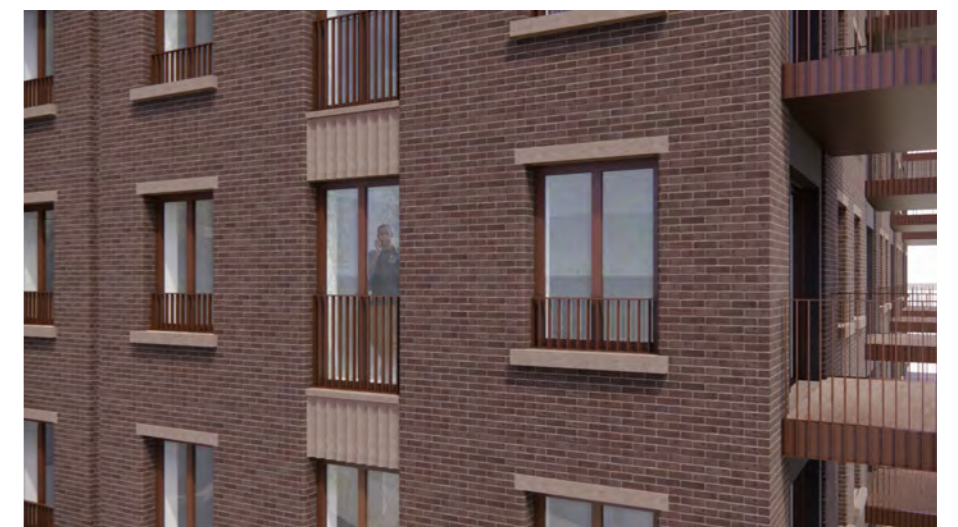

Typical gable elevation





Sketch showing the relationship of Building 4.5 to the re-established canal basin



Purple-brown waterstruck bricks



Dark brown glazed bricks



Pinkish grey reconstituted stone



Dull maroon metalwork



## 8.7.6 Lobbies

The lobbies and communal spaces for Plot 4 are intended to reflect the character of their host buildings but have, in common, a sense of grandeur with a contemporary expression. The tower, Building 4.1, will have a large foyer with a post room beyond, both with a mid-century minimal aesthetic. The former has a terrazzo floor and lower walls, with an inlaid patterned terrazzo tiled floor. The post room however is softer, with a timber floor and postboxes as furniture in space rather than embedded in a wall as would be typical.

The mansion blocks (Buildings 4.2, 4.3 and 4.4) refer subtly to their Nineteenth Century precedent. Specifically, they are a series of wood-panelled rooms with, as per Building 4.1, patterned terrazzo floors and wearing surfaces. In the lobbies, large furniture-like screens conceal platform lifts to their rear, presenting bookcases to a homely seating area, where a decorative terrazzo tile floor reiterates the geometry of the bay window it occupies. The post rooms are similar in style with ample room to dwell.

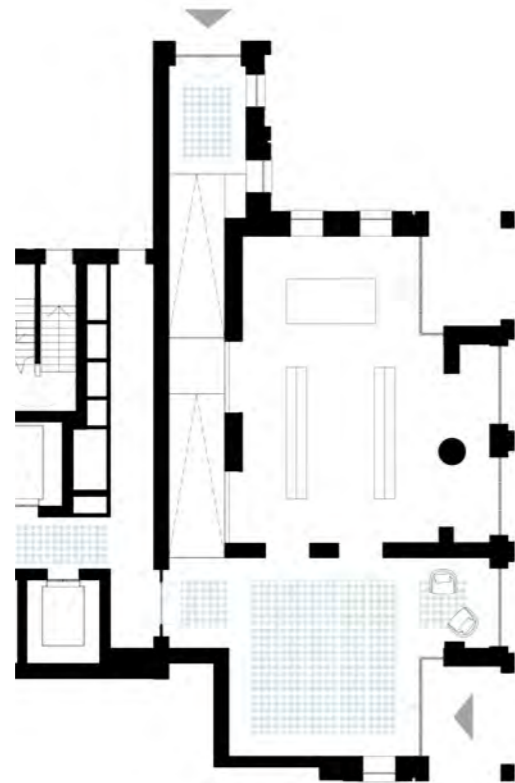

Building 4.1 lobby



Building 4.1 lobby and post room



Building 4.1 lobby





Building 4.4 lobby



View 4: mansion block typical residential corridor

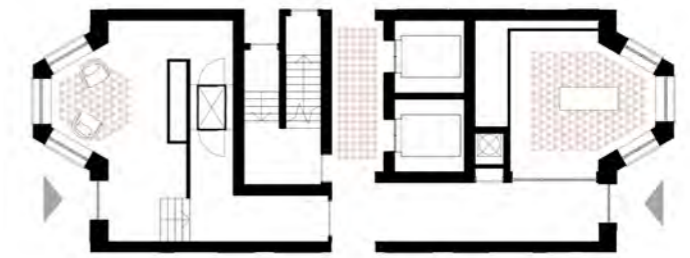

Building 4.2 and 4.4 lobby and post room



Building 4.4 post room



Building 4.3 lobby

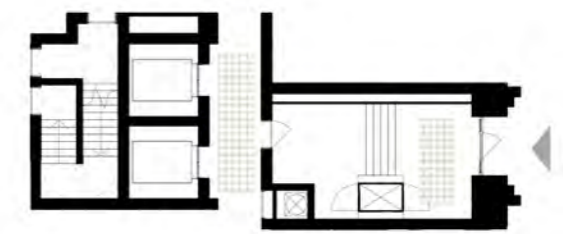

Building 4.3 lobby



## 8.8 Sustainability

This section should be read in conjunction with the Energy Strategy and Sustainability Statement prepared by Hoare Lea.

Sustainability is at the heart of the design for Plot 4 and our proposals seek to address all aspects of environmental, social, and cultural sustainability. Its design aims to protect and enhance the site's ecology and biodiversity while using the site effectively and creating an environment that will nurture and support the community.

Canalside Park, the courtyard gardens, and the biodiverse green roofs are all designed to enhance ecology and biodiversity, contribute to urban heat island mitigation, and provide rainwater attenuation.

We have designed the buildings to last for a long time and age gracefully, prioritising long-lasting quality materials with low environmental impact, and to minimise air, noise, light, and water pollution. All external envelopes will be composed of non-combustible materials. The principles of circular economy will be used throughout design, construction, and end of life.

The design aims to optimise the health and wellbeing of residents with good levels of internal daylight, thermal comfort, safety, and security. A high proportion of dual aspect dwellings ensures good access to daylight and natural ventilation whilst loggias provide passive solar shading. The design promotes active travel with new pedestrian links and good cycling facilities.

In addition to new homes, the site will provide a variety of new green spaces and attractive public realm with soft and hard landscaped areas, low levels of residential parking, canalside leisure opportunities, as well as opportunities for businesses and services catering for the local community.

The Energy Strategy follows the principles of "Be Lean", "Be Clean" and "Be Green". We are taking a fabric first approach to reduce heating demand and commercial spaces will target a BREEAM rating of 'Excellent'. The proposed energy strategy incorporates a low carbon community network at ambient temperature, served by Air Source Heat Pumps, local ventilation units will be equipped with heat recovery units to enhance efficiency and reduce heat losses and photovoltaic panels will use all available roof space.





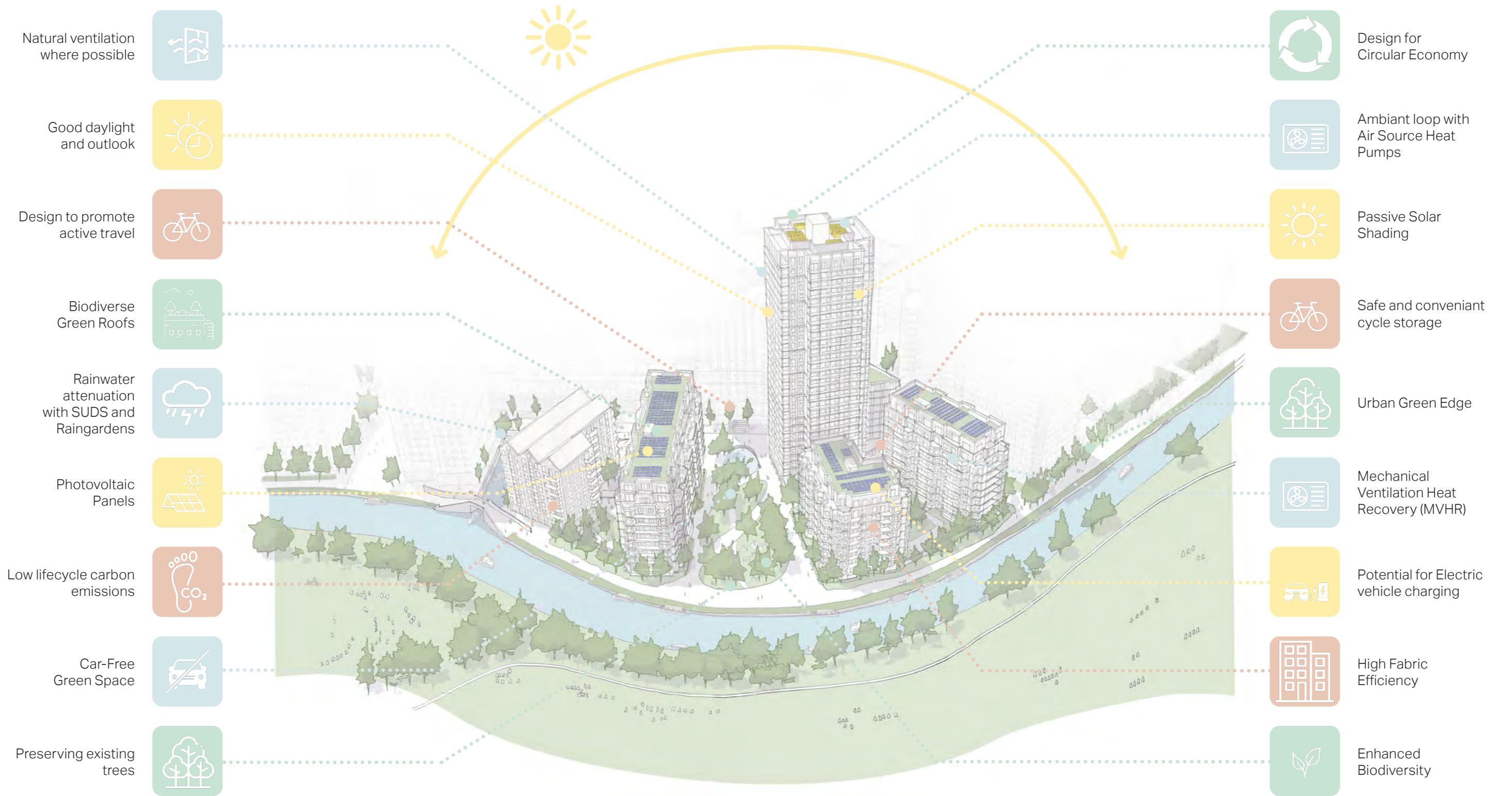







# 9.0 Illustrative Proposals - Plot 1

<b>9.1</b>	<b>Design Summary and Explanation</b>	<b>276</b>	<b>9.7</b>	<b>Appearance</b>	<b>296</b>
9.1.1	Plot 01 Context & Analysis	276	9.7.1	Residential Perimeter Block	296
9.1.2	Plot 01 Narrative	278	9.7.2	Crescent: Townhouses	300
<b>9.2</b>	<b>Layout</b>	<b>280</b>	9.7.3	Crescent: Gable	302
9.2.1	Site response	280	9.7.4	Crescent: Crown	304
<b>9.3</b>	<b>Height and Massing</b>	<b>286</b>	9.7.5	Pavilion: The Local Bistro	306
9.3.1	Heights & Context	286	<b>9.8</b>	<b>Sustainability</b>	<b>308</b>
<b>9.4</b>	<b>Use</b>	<b>289</b>	9.8.1	Overview	308
9.4.1	Commercial Use	289			
9.4.2	Residential Use	291			
<b>9.5</b>	<b>Amount</b>	<b>293</b>			
9.5.1	Residential Distribution	293			
<b>9.6</b>	<b>Residential Quality</b>	<b>294</b>			
9.6.1	Outlook, Aspect, Proximity	294			







**Occupying the southern half of the gateway into the masterplan, Plot 01 serves as an anchor to mediate the scale of buildings on Ladbroke Grove with those within the wider masterplan.**

Plot 01 acts alongside Plot 06 in creating a threshold moment at the entrance to the site, responding directly to the lower storey buildings facing the site. Architecturally it draws inspiration from the regency housing of Arundel and Ladbroke Gardens, directly to the south, and the gardens which they front which inspire the crescent form and the material palette of the plot.

The northern edge of the plot faces The Avenue and as such is a key component in the new neighbourhood centre. The plot extends south to meet the Great Western Mainline and its central streets are populated with units capable of hosting a variety of functions at ground level including workshop spaces, affordable office provision, retail units and a creche facing South Terrace.

The upper levels of the plot are populated with new homes, where the increased building height affords uninterrupted views south across the borough.



# 9.1 Design Summary and Explanation

## 9.1.1 Plot 01 Context & Analysis

Plot 01 is a significant part of the overall site as it bounds the South-Eastern edge of the development occupying a prominent corner of the masterplan, in direct contact with existing urban tissue.

### 9.1.1.1 Plot Boundaries & Constraints

The primary physical constraint to the Plot 01 site is the Great Western Railway mainline along its Southern edge. The buildings will sit away from the railway and will provide generous space along the South of the site for public realm, accomodating the South Park.

The north edge of the plot is bounded by The Avenue, which is the main thoroughfare for pedestrian and vehicles into the masterplan.

To the West, it is the road extents and distance to Plot 02 which determines the boundary of the plot. The buildings are recessed from the North-South key axis that visually connect the footbridge over the railway with the main access point to the Canal through plot 05.

To the East of the Plot sits the Grade II\* listed Kensal House, a modernist housing estate by architect Maxwell Fry, completed in 1937. Kensal house triggers key design guidelines for the plot, such as the lowering scale approaching Ladbroke Road, and the crescent shape for block 1.1

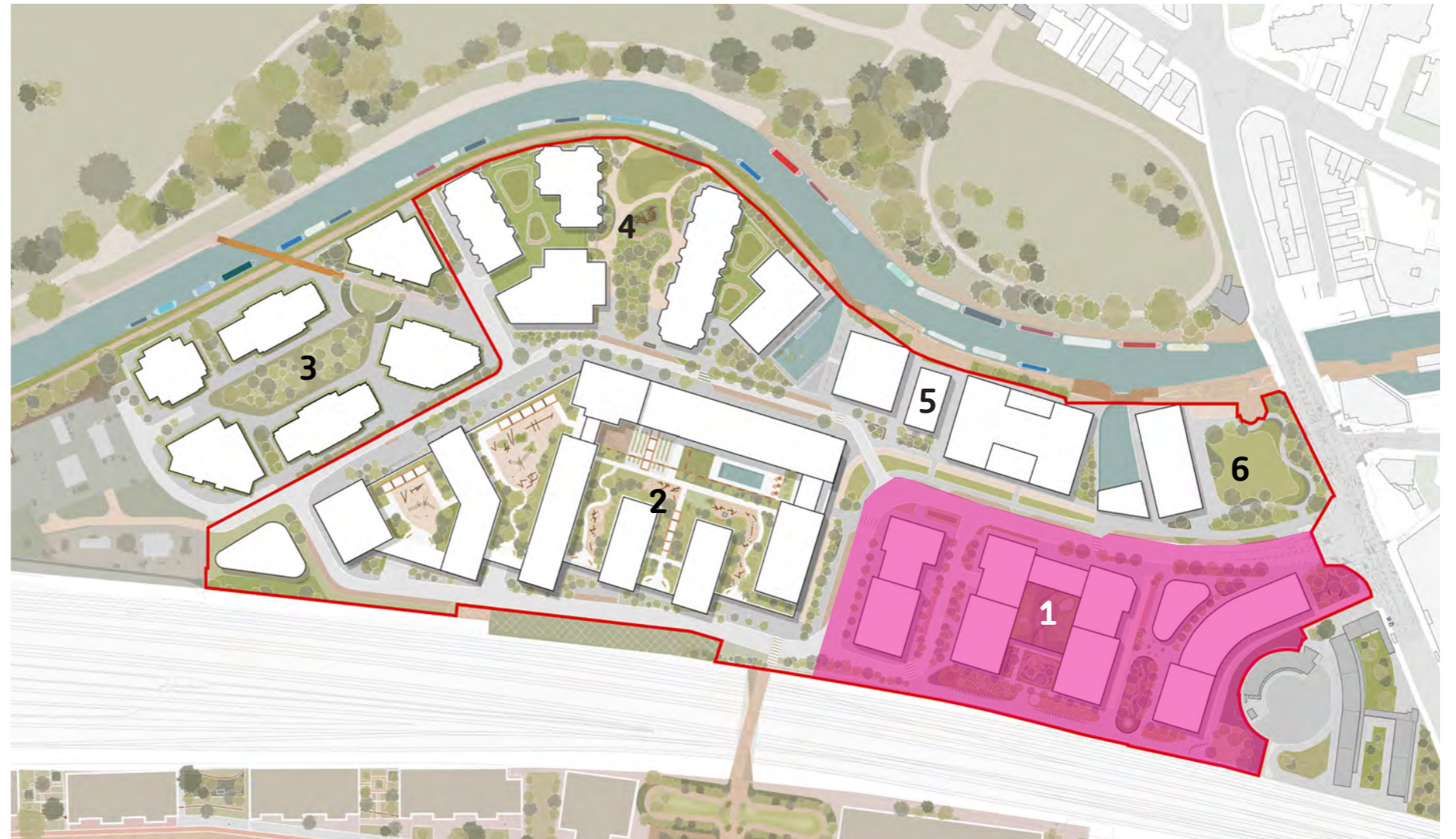

Fig 9.3: Plot 01 Extents



Fig 9.1: Key Constraints



Fig 9.2: Context & Constraints: Key Splines



### Role In Masterplan

Occupying over 19585 sqm on the South Eastern corner of the site, Plot 01 constitutes an important presence in the Masterplan. The plot shares a key position as site Gateway along with Plot 06 and, offers a near 200m long elevation towards The Avenue, providing key street activity.

The plot is comprised of 4 finger blocks and a smaller pavilion building. The finger blocks are massed so that they present their lower 'shoulders' to the Avenue and introduce a more human scale to this pedestrian boulevard. The taller elements of Plot 01 are placed against the railway line, to make the most of the southern vistas and views to the wider borough. Height is carefully considered here, so that the lowest of the 4 towers (Plot 1.1) lies closest to Kensal House and a gradual incline in height is provided towards Plot 1.3. Plot 1.4 then steps down to provide greater prominence to the adjacent Plot 2.1 marker building.

The orientation of the blocks allows for natural light to filter through the plot and reach the North of the site, as well as the configuration of varied streetscapes around the plot. (See Chapter 04. Design Code).

The plot contains a number of gestures which address the entrance to the site, given its position as part of the threshold from Ladbroke Grove. Plot 1.1, the crescent shaped building, presents a 7 storey gable at the site entrance, lending a character which is familiar to regency buildings in the borough. From this point a pavilion building emerges (Plot 1.1.3), creating a 2 storey counterpoint to the larger buildings which surround it and drawing inspiration from local public houses, such as The Black Friar, eccentrically shaped to provide a 'prow' to the adjacent street. This approach is further reinforced at the north eastern edge of Plot 1.2, which presents a narrow prow on its corner to naturally guide pedestrians into the site.

From this point the principle character of Plot 01 is established, with an active commercial ground floor facing the Avenue and the surrounding streets and residential units sitting above this animated podium, inviting visitors and residents to engage with the building.

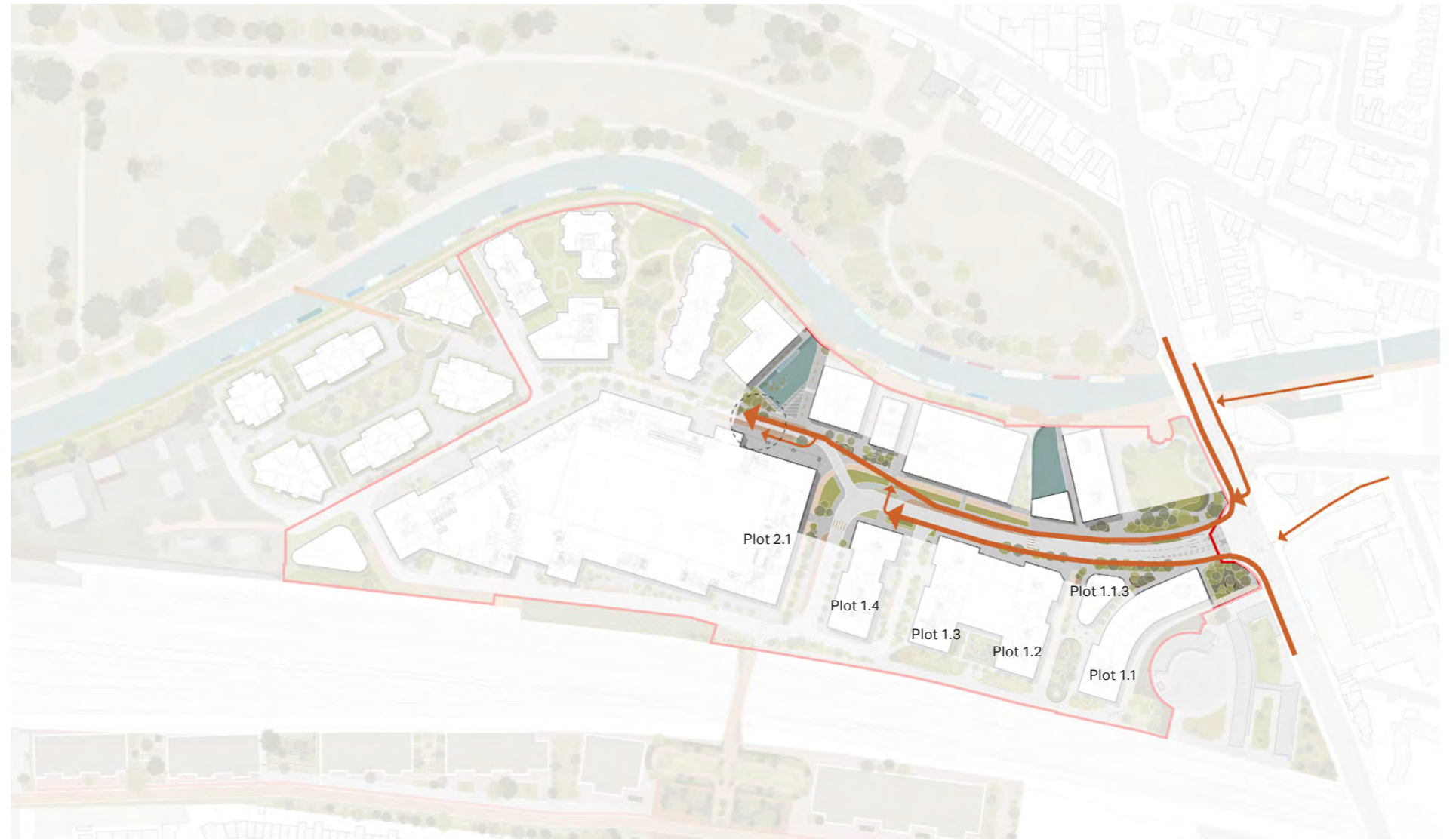

Fig 9.4: Pedestrian Experience - Exploring from East



Fig 9.5: Pedestrian Experience - Exploring from South

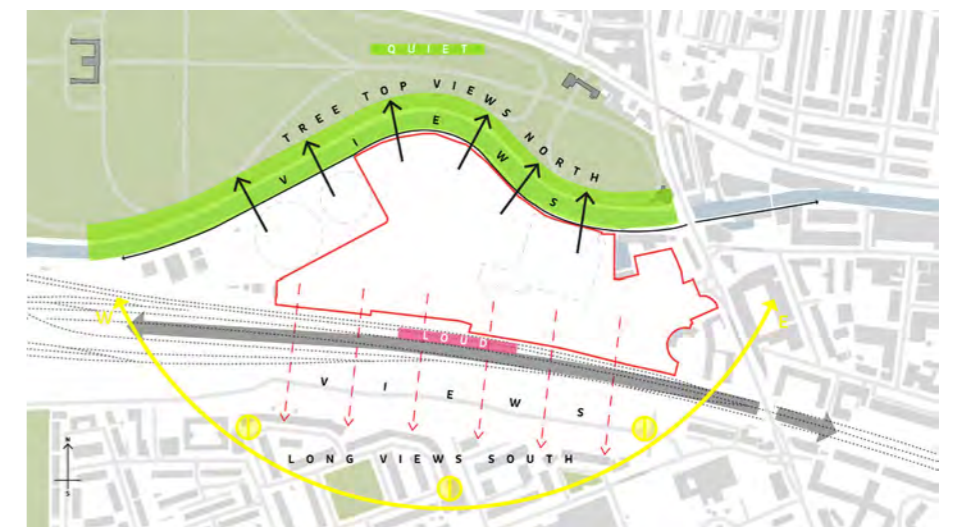

Fig 9.6: Key views



## 9.1.2 Plot 01 Narrative

Plot 01 design narrative emerges from a process of careful analysis of the borough's local vernacular. There are strong urban planning and architectural features that define the Plot's character, which are inspired by those elements that are essential to the architectural identity of West London. Elements of Regency architecture from both a macro and micro scale are incorporated to the design as part of a recipe for a contemporary interpretation of the classical heritage of the area.

The Plot incorporates the Crescent, one of the most representative residential typologies in the Borough as one of its strongest design principles.

Looking further into North Kensington's architectural anatomy, the rounded street corner appears as one of its key streetscape features. This urban shape is incorporated to the design as another way of showcasing the area's architectural tradition in urban design.

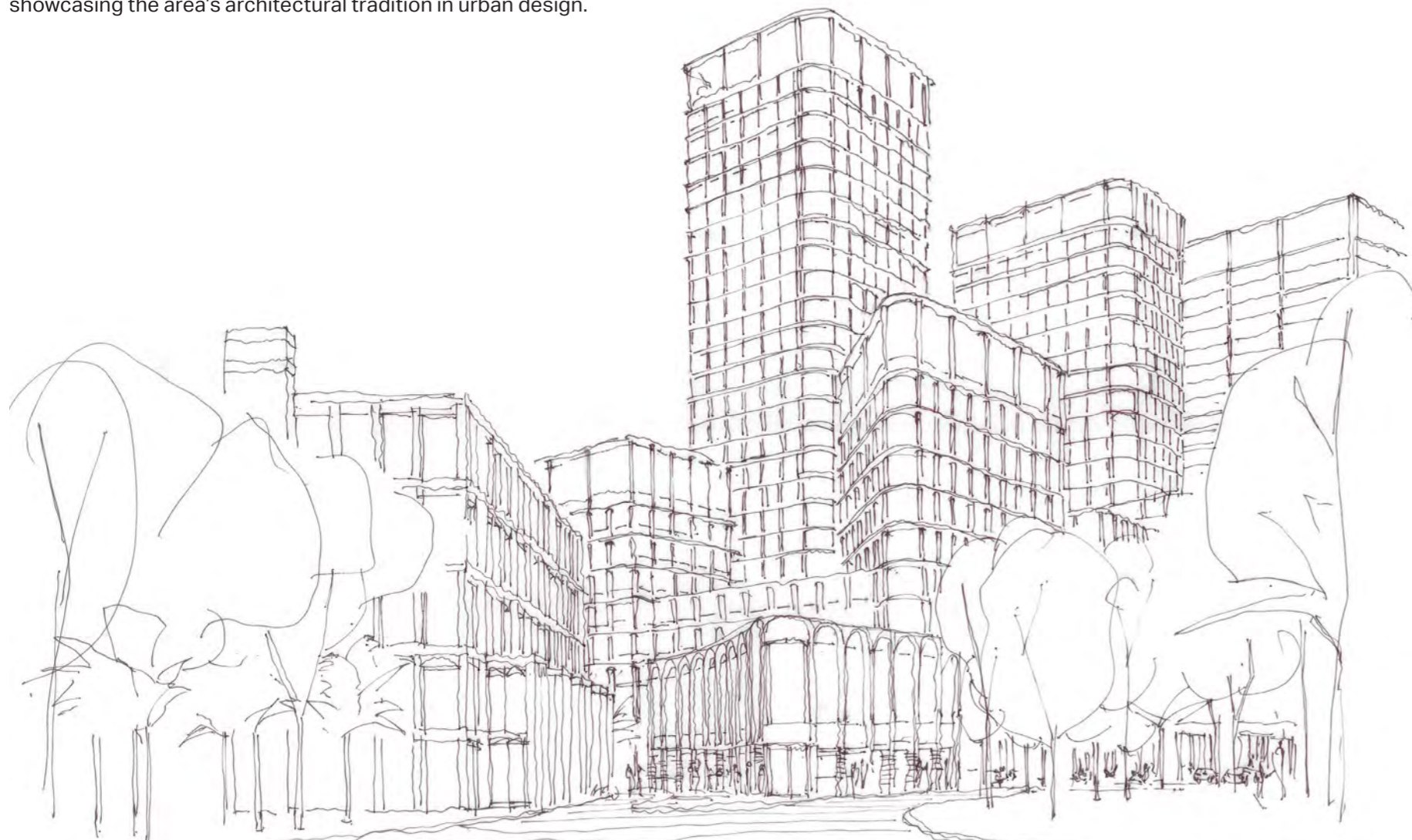

Fig 9.8: Early Look & Feel Sketch



Fig 9.7: Crescent Facade Precedent



Fig 9.9: Plot 01 - Interpreting the crescent terrace





Fig 9.10: Regency corners on Portland Road



Fig 9.12: The Distillery, 186 Portobello Road



Fig 9.14: West Kensington Regency Housing



Fig 9.11: Exploring corner typologies



Fig 9.13: Early concept sketches referencing the regency vernacular



# 9.2 Layout

## 9.2.1 Site response

The buildings which make up Plot 01 are all being brought forward in outline within the application. The landscape surrounding the plot is in detail on the western edge of the plot and detailed landscape drawings have been produced to accompany the application.

To the east and south of the plot the proposals are being submitted in outline. As shown on the key below, the main elements of landscape which surround the plot include South Terrace, Crescent Link and the pocket park at the site entrance. The existing memorial garden will be retained in its current position and will be sensitively integrated into the overall landscape proposals here. The pocket park itself has a dialogue with Ladbroke Gardens on the eastern edge of Plot 06. Trees and generous planting on both sides of the road are intended to frame the site entrance, acting to draw pedestrians into the heart of the masterplan beyond. The pocket park will provide seating and will incorporate a new pedestrian route which will follow the sweep of the Plot 1.1 facade down toward South Terrace.

The following pages show the illustrative scheme, and demonstrate the key elements which make up Plot 01.

Key:

- Outline application
- - - Extent of detailed application
- 1 Ladbroke Gardens
- 2 Boathouse Basin
- 3 Raingardens
- 4 Denby Square
- 5 New Wharf
- 6 Pocket Park
- 7 South Terrace
- 8 Memorial Garden
- 9 Widened footpaths
- 10 Lowered boundary wall

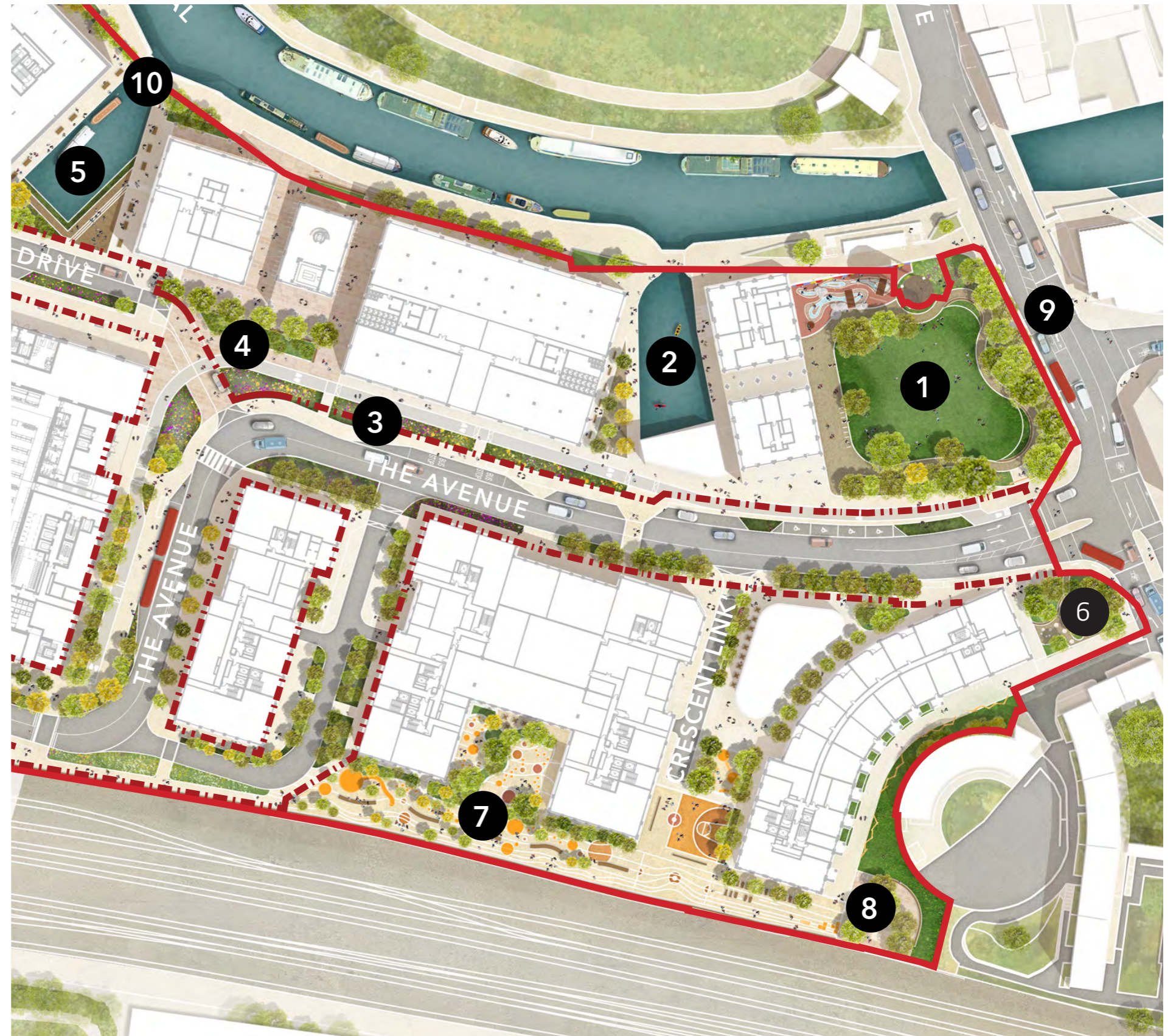

Fig 9.15: Landscape Masterplan - Note landscape



### 9.2.1.1 Basement Strategy

The basement of Plot 01 has been designed to house ancillary functions for Plot 01 such as cycle stores and plant rooms to service the residential units above. The scheme also includes an automated parking system. Here, residents would pull into a lift at ground floor level and the car would be automatically placed into one of the spaces within the basement.



- Key**
- 1 Automated double stacked parking
  - 2 Bike Store - Private
  - 3 Plant
  - 4 Plot 1.1.3 Ancillary

Fig 9.16: Illustrative scheme - Basement Plan



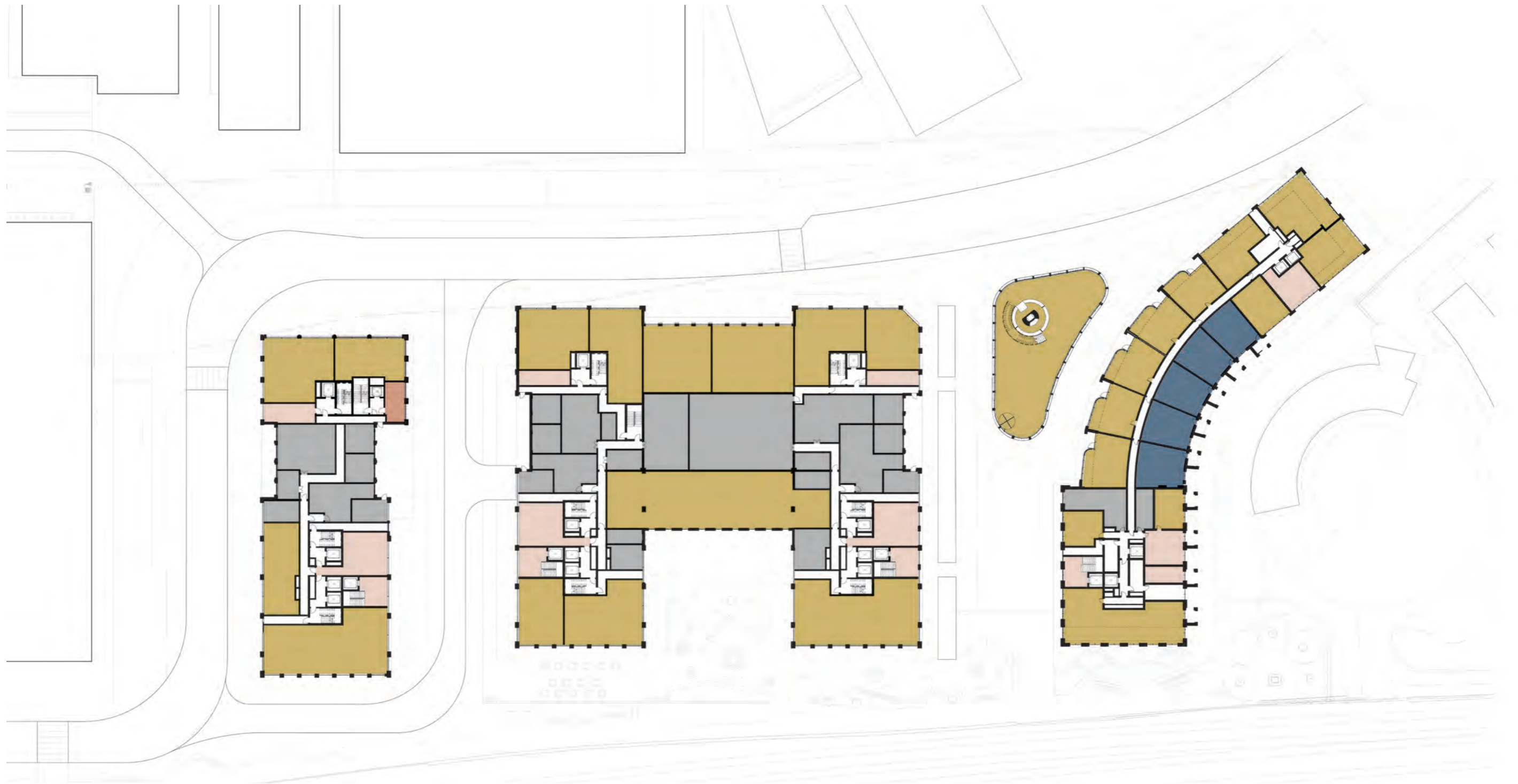

- COMMERCIAL
- RESI LOBBY/ AMENITY
- PLANT
- TOWNHOUSE

Fig 9.17: Illustrative scheme - Level 00 Plan



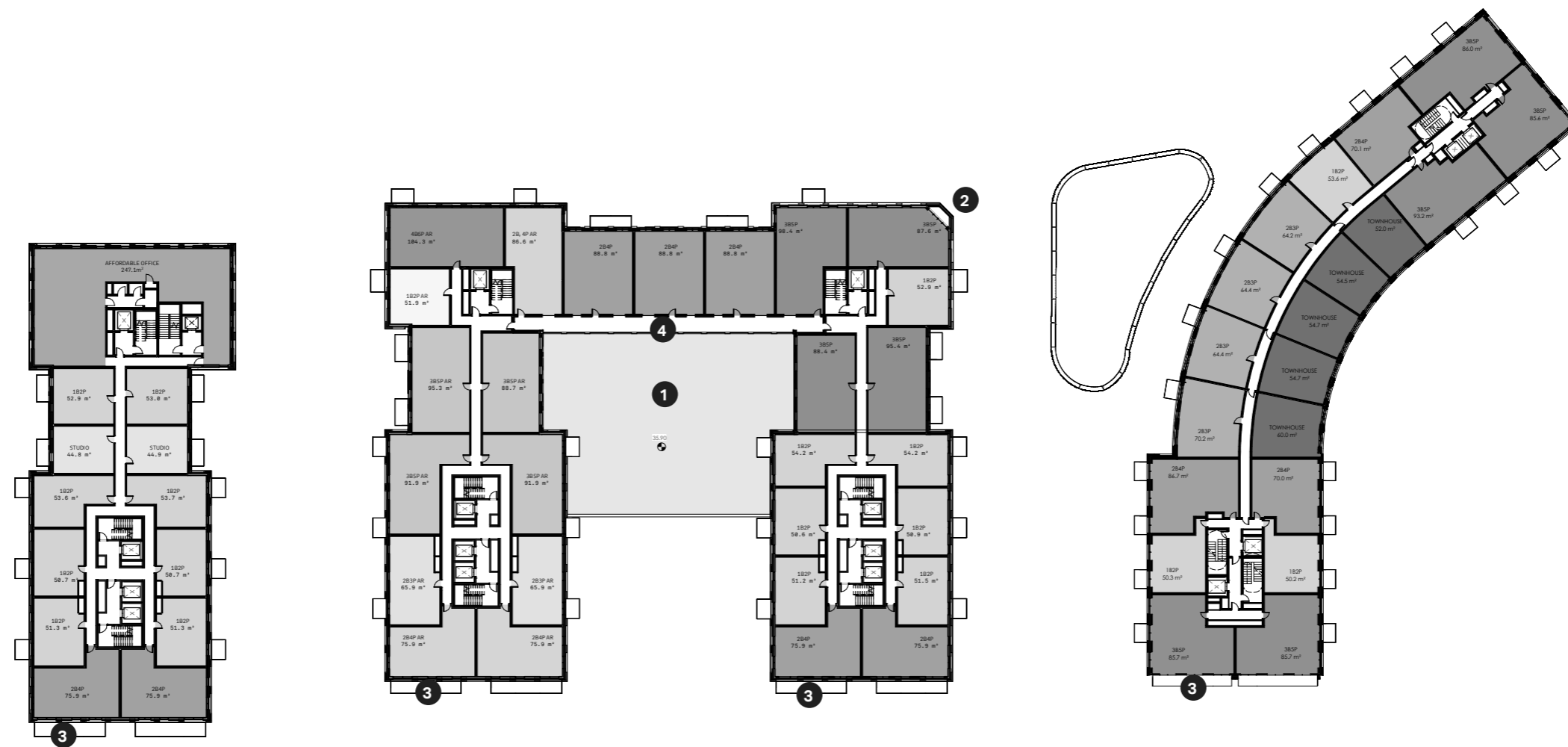

**External Amenity Spaces Key**

- 1 Communal gardens
- 2 Corner balconies
- 3 Projected balconies
- 4 Access porch balcony
- 5 Rooftop Terrace

Fig 9.18: Illustrative scheme - Typical Lower Level Plan with option for Level 01 Office



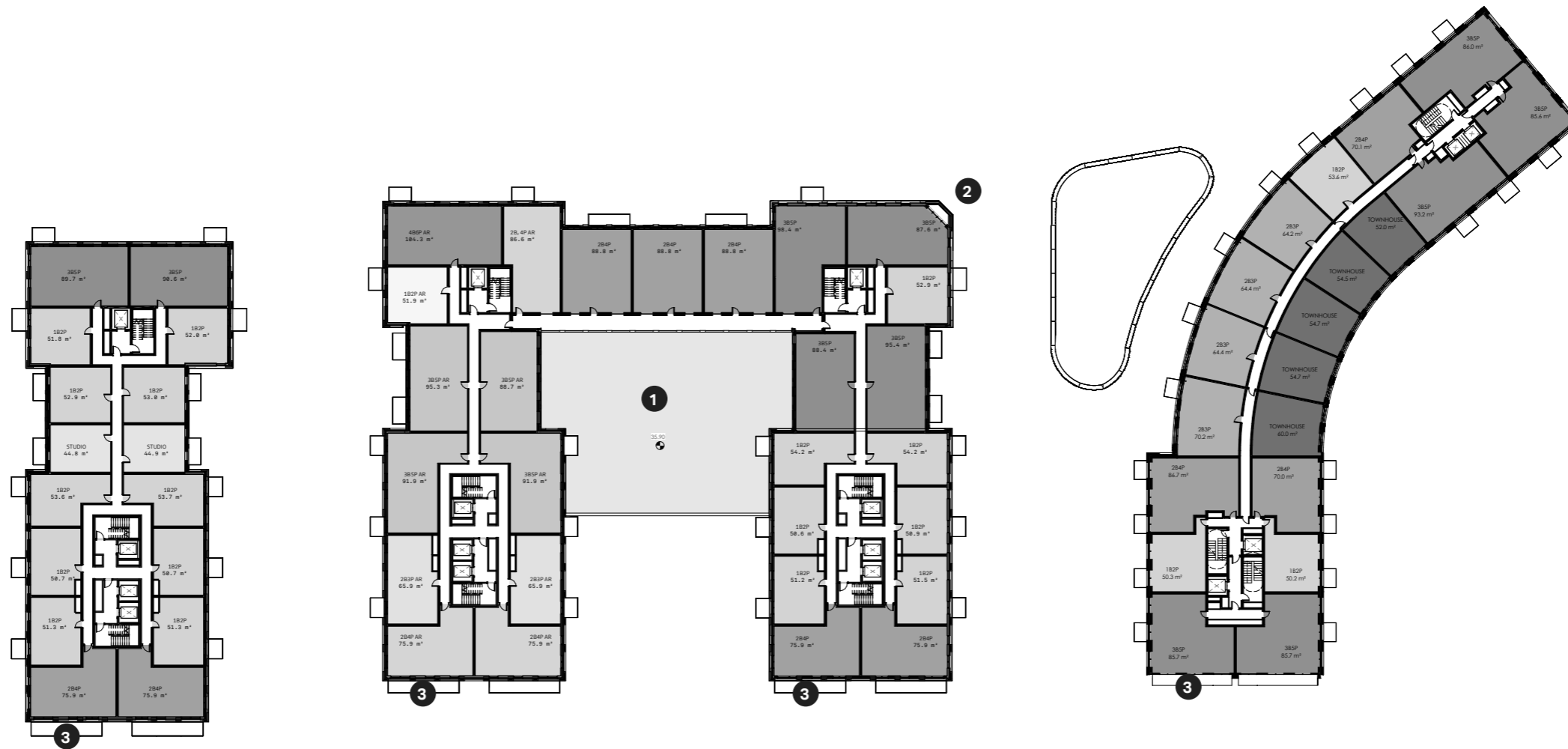

**External Amenity Spaces Key**

- 1 Communal gardens
- 2 Corner balconies
- 3 Projected balconies
- 4 Access porch balcony
- 5 Rooftop Terrace

Fig 9.19: Illustrative scheme - Typical Lower Level Plan



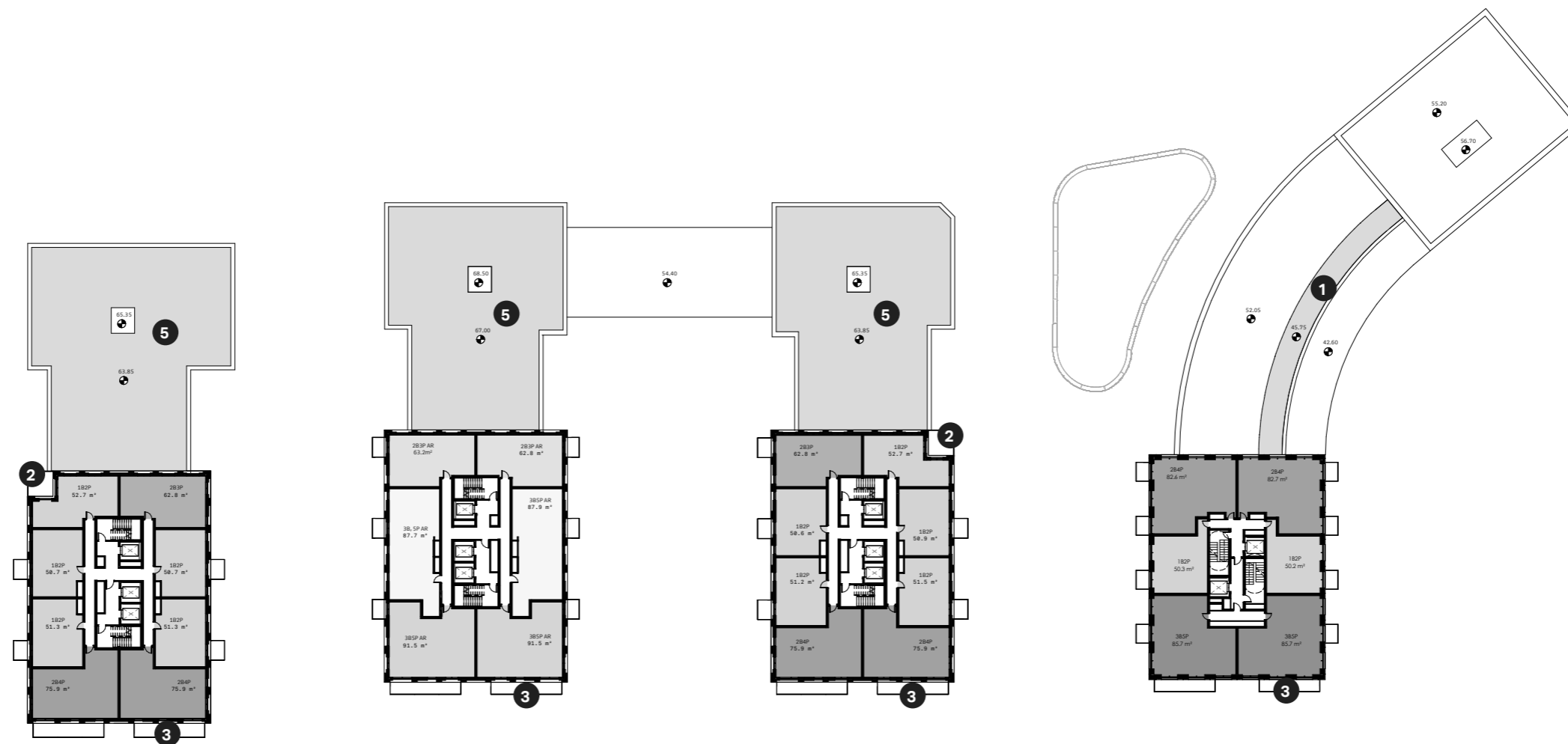

**External Amenity Spaces Key**

- 1 Communal gardens
- 2 Corner balconies
- 3 Projected balconies
- 4 Access porch balcony
- 5 Rooftop Terrace

Fig 9.20: Illustrative scheme - Typical Upper Level Plan



# 9.3 Height and Massing

## 9.3.1 Heights & Context

Occupying the South-Eastern corner of the development, the outline of Plot 01 emerges as the front cover of the site as residents travel North along Ladbroke Grove. The South-facing elevation stands across the railway taking the void as an opportunity to grow in height. The North elevation however is scaled down to offer a more pedestrian-sized experience towards the Avenue.

The plot is arranged in varying heights to adapt to the surrounding context and built environment. An example of this is shown in the East-West section (Fig. 8.34), where heights are gradually scaled down to respect the neighbouring Kensal House.

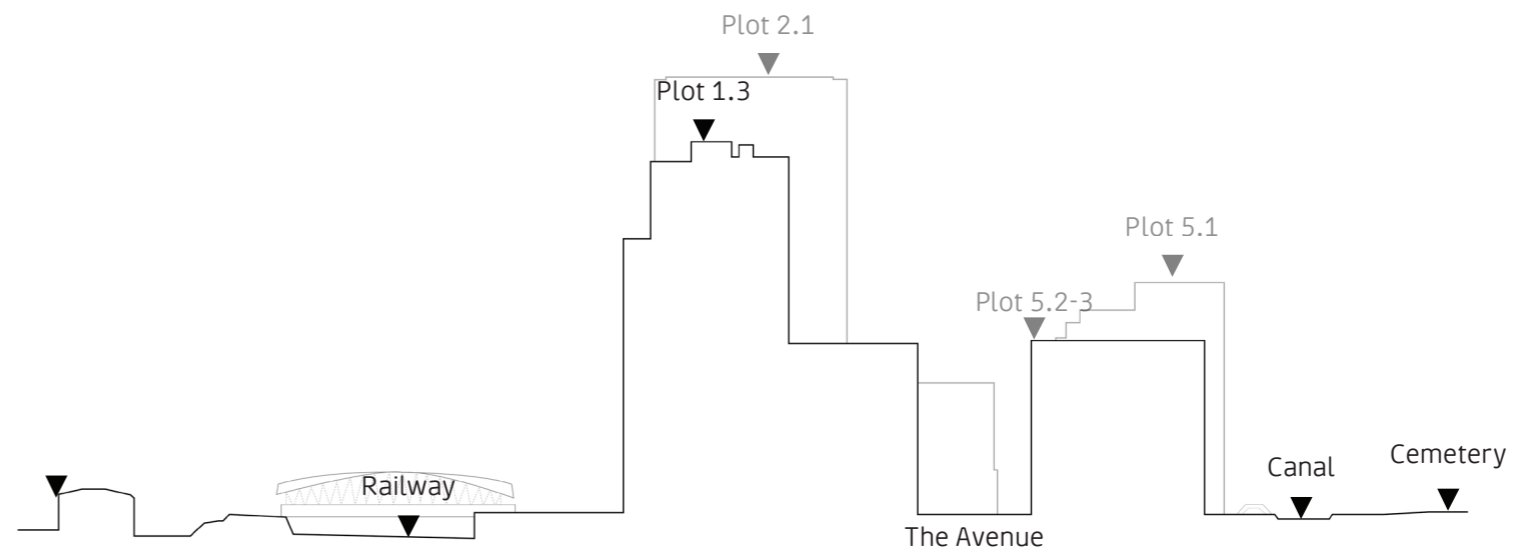

Fig 9.22: North-South Context Section

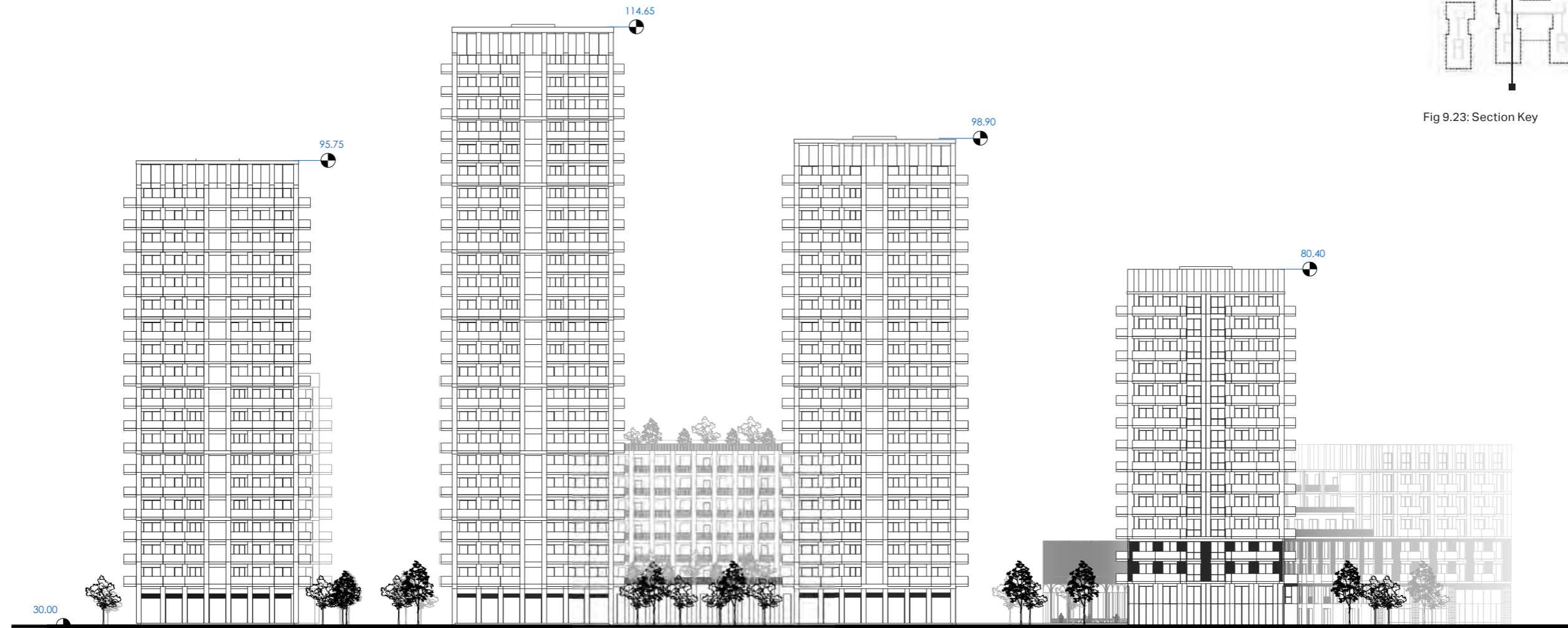

Fig 9.21: South Elevation Illustrative Scheme - showing indicative AOD heights (m)

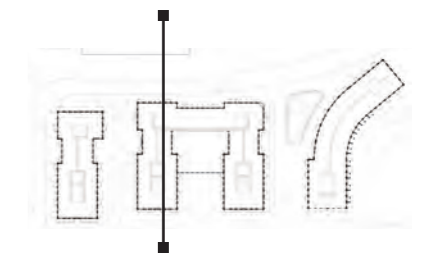

Fig 9.23: Section Key



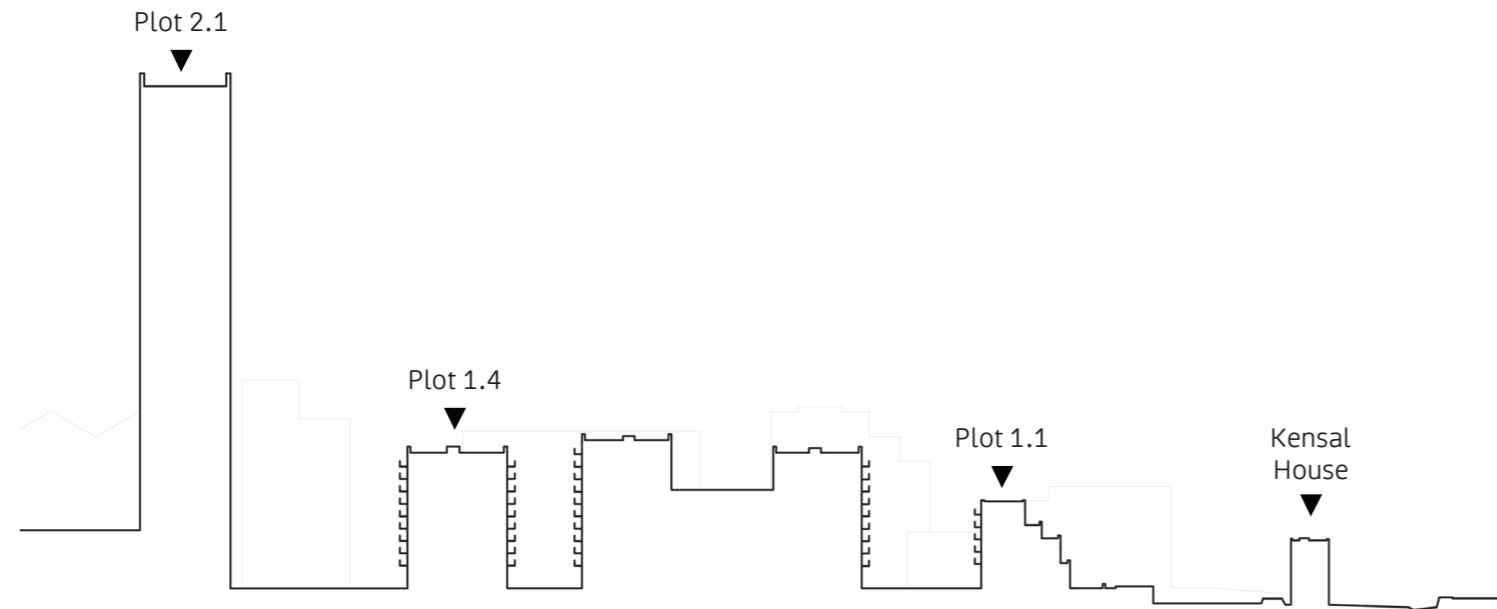

Fig 9.24: East-West Context Section through 'shoulders' of Plot 1

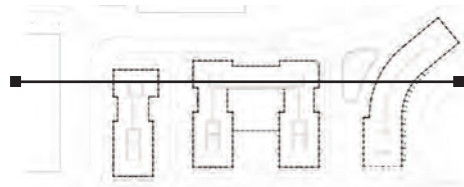

Fig 9.26: Section Key

### 9.3.1.1 Further Testing

Drawings on this page illustrate the principle of stepping down Plot 01 buildings to address adjacent the immediate context, such as Kensal House to the east, and Plot 2.1 to the west.

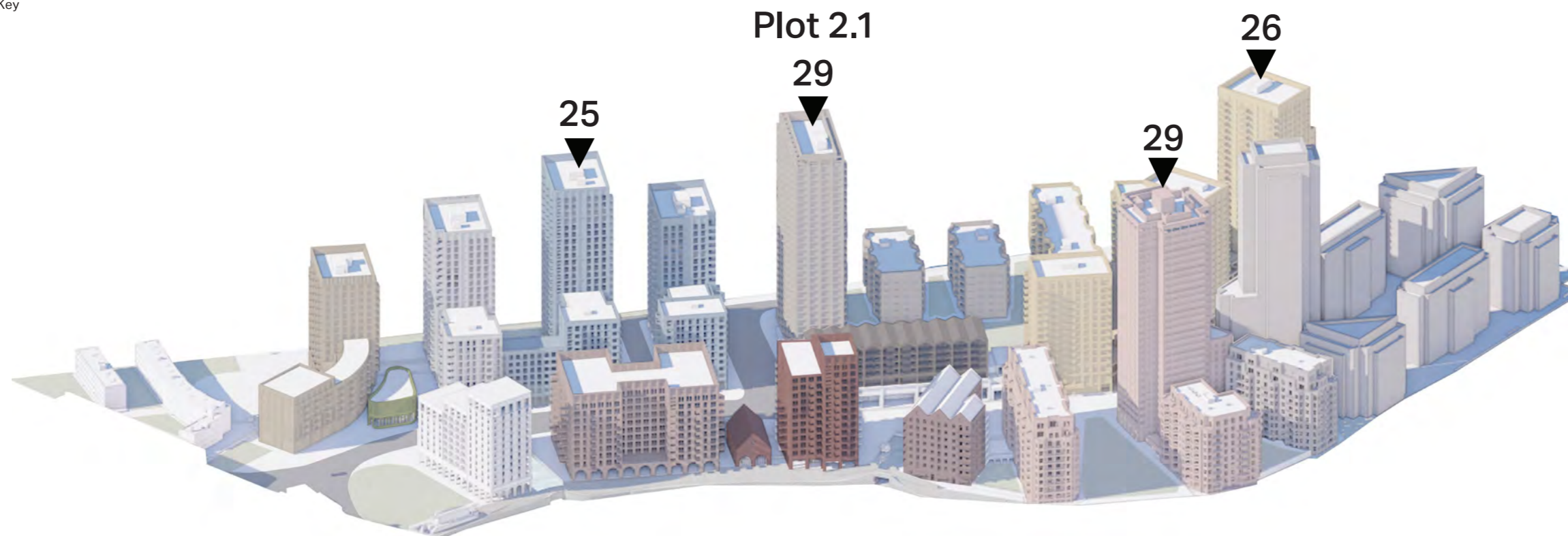

Fig 9.25: Axonometric View showing graduation of illustrative building heights towards plot 2.1





Fig 9.28: Site wide axonometric showing Plot 1 in context with the surrounding masterplan and borough - View looking south



Fig 9.29: Site wide axonometric showing Plot 1 in context with the surrounding masterplan and borough - view looking north



# 9.4 Use

## 9.4.1 Commercial Use

Plot 01 presents key street frontage within the site, becoming an important showcase of the area's commercial and creative ecosystem.

### 9.4.1.1 Creative Workspace

The RBKC Local Plan (2019) highlights the importance of the creative sector in the borough in contributing to local economic growth as well as promoting local identity and fostering innovation.

The ambition for the Kensal Canalside Opportunity Area (KCOA) is to act as a catalyst for regeneration throughout North Kensington, offering employment opportunities and spaces that will foster the cultural and creative industries through the provision of a new Neighbourhood Centre..

This target creative sector includes businesses related to Art & Design, which have specific space requirements to house a wide variety of activities. The use of flexible spaces will offer an adaptable platform for offices, studios, rehearsal spaces, workshops, and community spaces.



Fig 9.30: View of Plot 1 from Ladbroke Grove





Fig 9.33: Commercial frontage - Plot 01 Crescent link street



Fig 9.31: Flexible Workspace Inspiration



Fig 9.35: Flexible Workspace Inspiration

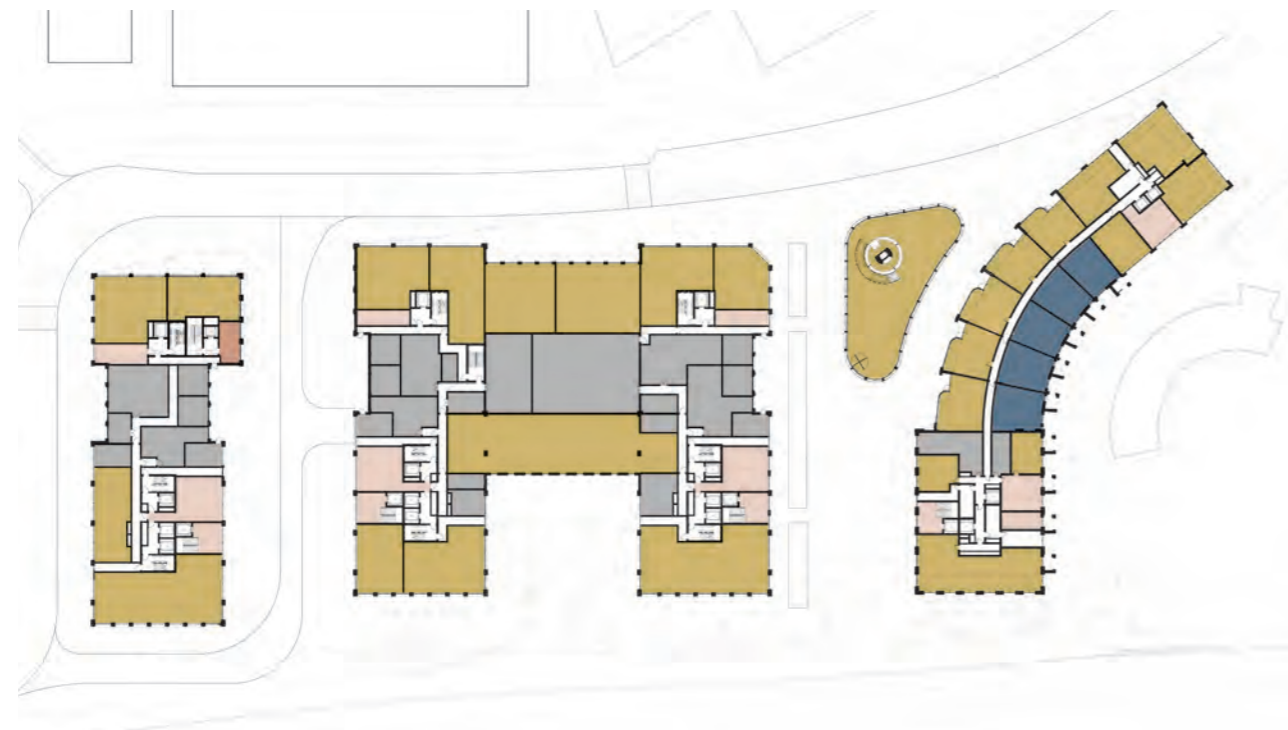

Fig 9.34: Illustrative scheme Commercial frontages at Level 00 (shaded mustard)



Fig 9.32: High Street Retail Inspiration



Fig 9.36: High Street Retail Inspiration



## 9.4.2 Residential Use

Inspired by the Borough's rich array of residential typologies which include townhouses, mews, mansion houses, and tower blocks, Plot 01's residential palette offers a variety of spaces and scales.

### 9.4.2.1 Typology

From plot 1.1 to 1.4, homes are delivered responding to quality principles that manage to create intimate spaces within the plot wider scale. Access is layered with shared surfaces, pedestrian walkways, and raised communal gardens which offer opportunity scenarios for community life.

Block 1.1 responds to the crescent townhouse typology folding around Maxwell Fry's Kensal House.

Blocks 1.2 to 1.4 are arranged in two buildings of greater proportions, raised by a podium which houses all commercial uses as well as residential lobbies and BOH. Residential towers rise from the lower body of the buildings to varying heights around a clustered communal garden.

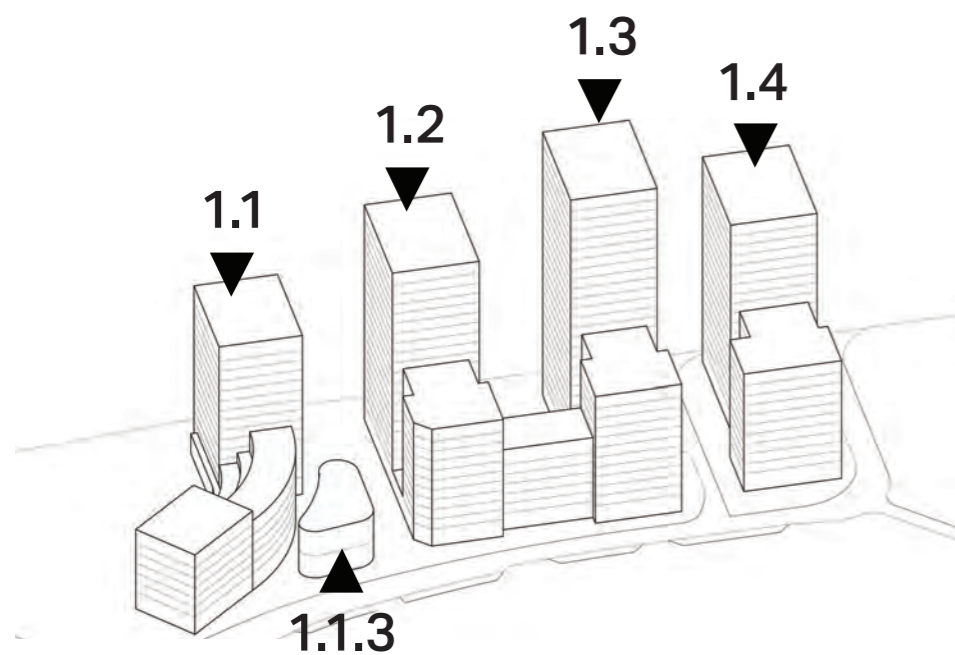

Fig 9.37: Residential Environment: Pedestrian streets



Fig 9.38: Residential Environment: Communal gardens



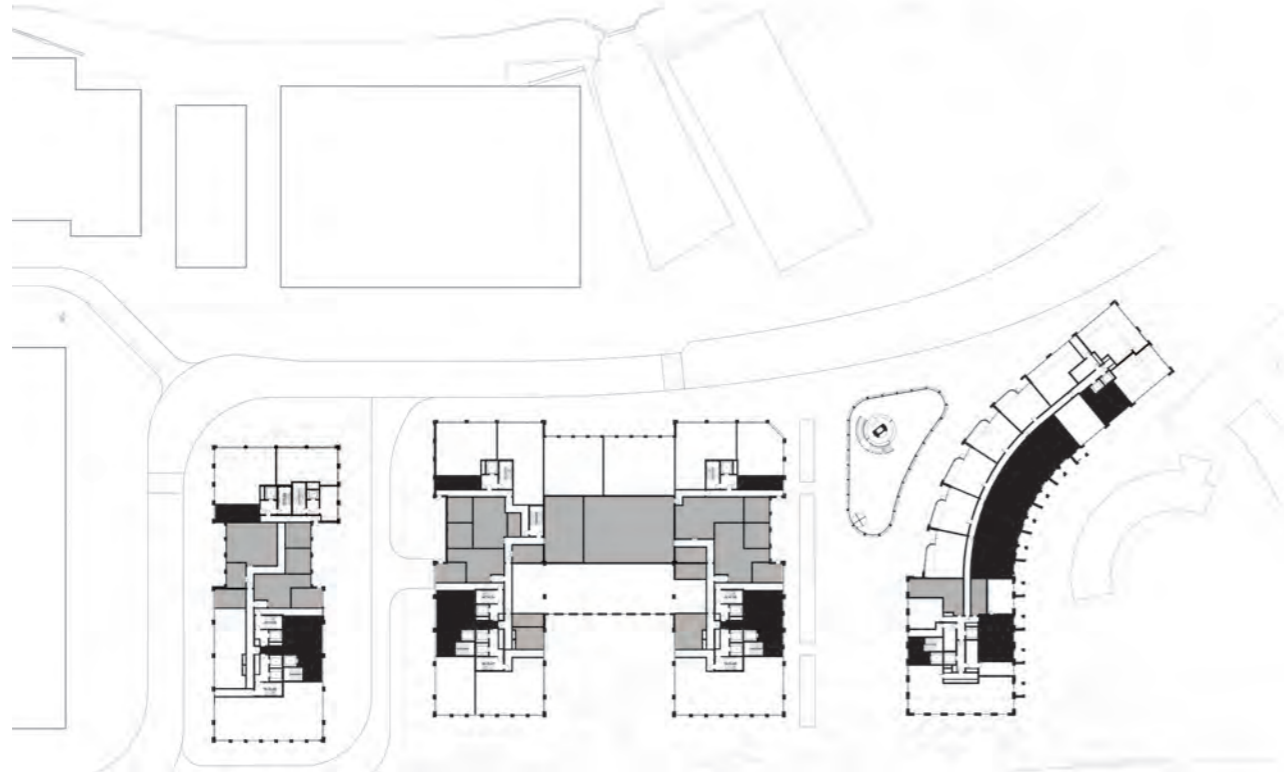

Fig 9.39: Illustrative scheme Residential Use. Ground Floor (shaded black)

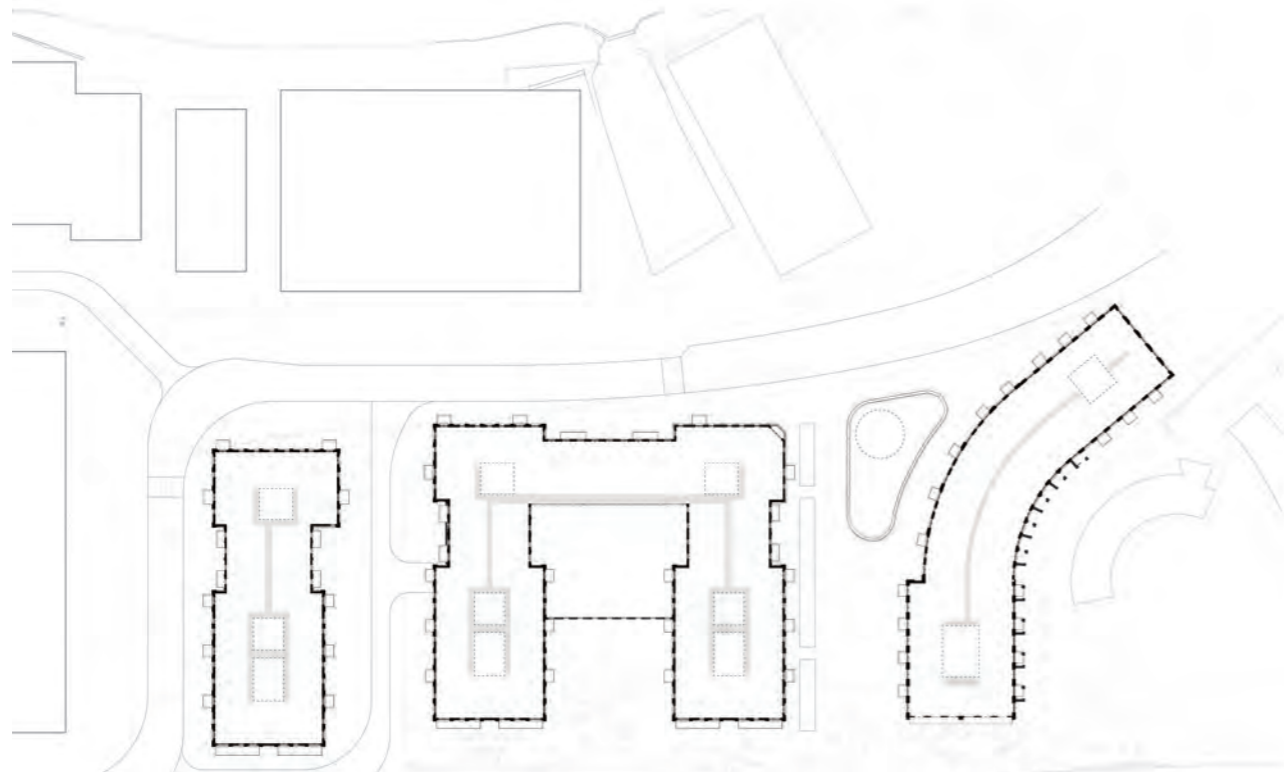

Fig 9.40: Residential Use. Typical Level



Fig 9.41: Illustrative scheme - South Terrace visualisation



# 9.5 Amount

## 9.5.1 Residential Distribution

Plot 01 provides a mix of both affordable and private sale homes across the plot. Within the illustrative scheme, shown adjacent, the tenure split has been distributed between the buildings in a way which integrates both private and affordable homes within an homogenous built environment offering shared communal gardens and play areas.

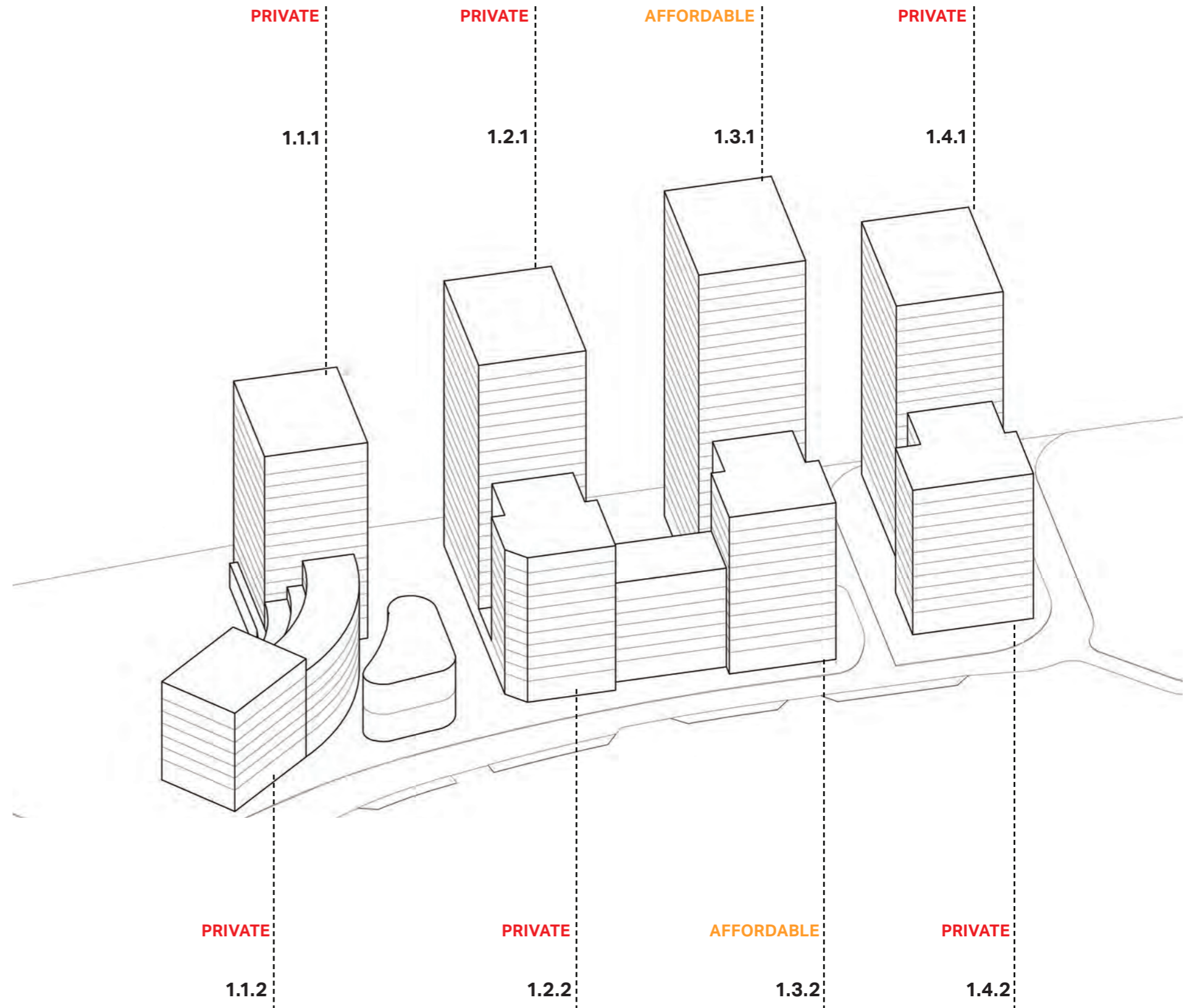

Fig 9.42: Illustrative scheme - Distribution of affordable and private homes



# 9.6 Residential Quality

## 9.6.1 Outlook, Aspect, Proximity

Plot 01 contains a range of house typologies and tenure mixes, spread evenly across the plot. Within the illustrative scheme approximately half of the units are dual aspect and these are shaded green below. Single aspect units have been orientated so they face east or west within the plot and as such the illustrative scheme contains no single aspect north facing units.

Plots have been carefully gauged so that the towers have generous offsets between them. These distances are highlighted in the diagram adjacent.

Apartments which face directly onto The Avenue are afforded a large offset to Plot 05 and are all dual aspect. On the southern edge of the Plot the units are also all dual aspect. These apartments will have fantastic views south across Kensington and Chelsea. Balconies placed on the southern facades will afford these amenity spaces with vistas across the borough. On the east and west flanks of Plot 01 all apartments will have balconies which will provide external amenity space, again these are afforded with uninterrupted views across the borough in a 180° arc.

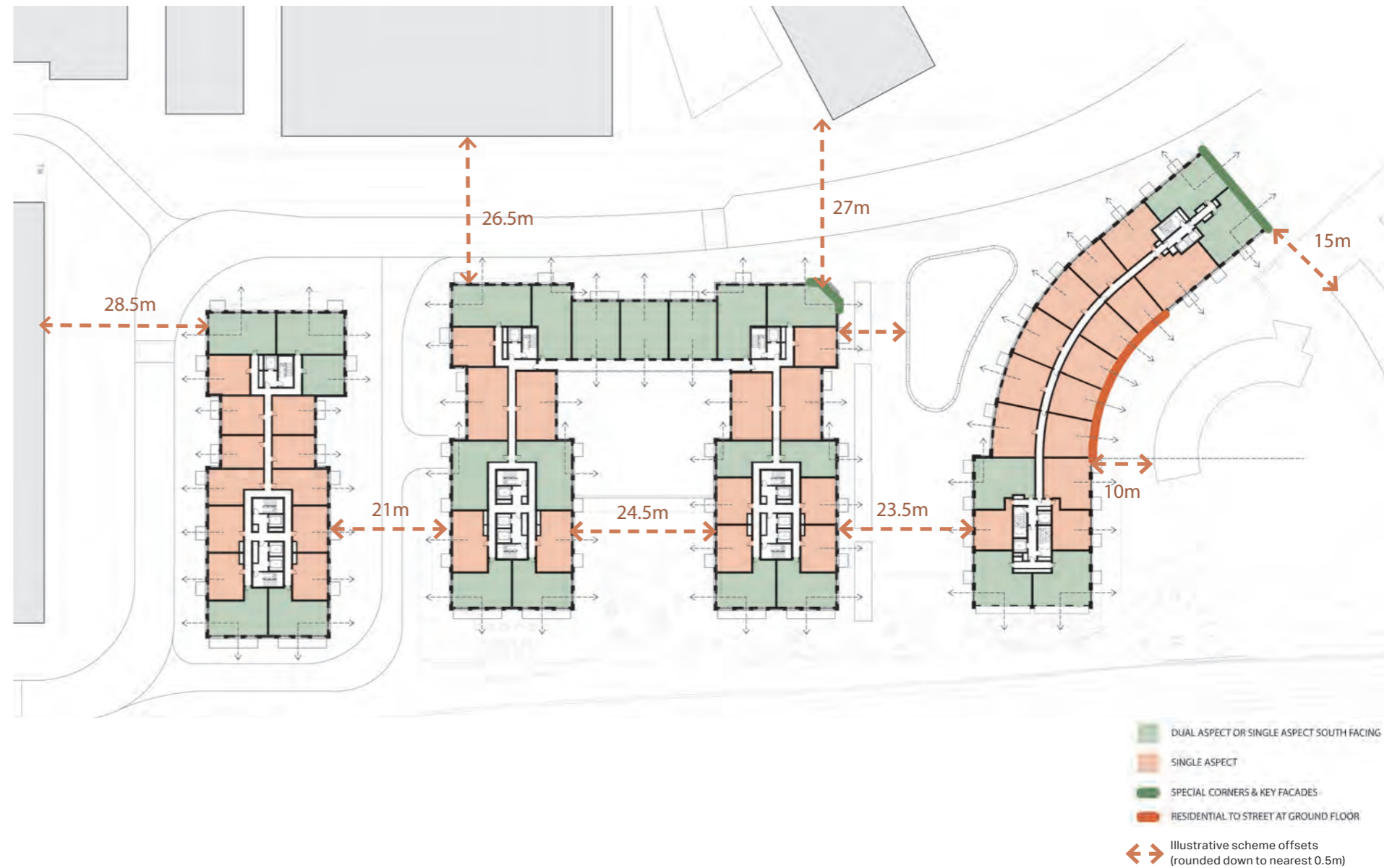

Fig 9.43: Illustrative scheme - Aspect and Proximity



This page is intentionally blank



# 9.7 Appearance

## 9.7.1 Residential Perimeter Block

### 9.7.1.1 Typology & Character

Buildings 1.2 and 1.3 are arranged as perimeter blocks around a central courtyard. This exposes a large proportion of the facade towards the street, which inspires parameter principles that will bring coherence to the scheme but also provide unique moments around the envelope. The block structure emphasizes the principle of a tripartite order: base, body and top that characterise both urban residential architecture as well as hybrid use buildings.

### 9.7.1.2 Material & Detail: Soft Edges & Pastel palette

The appearance of the buildings is informed by the historic character of the area. Round street corners, ornate cornicing and large bay windows stand out as one of the most characteristic features in victorian grand terraced housing in North Kensington. These elements are brought into the design and translated to shape volumes at an urban scale as well as to add grain and depth to the elevations.

Our contemporary interpretation of the traditional rounded shapes are curved corners which soften the building's edges but stand out a strong street markers.

Just as traditional stucco facades were painted in pastel colours across West London, we choose more contemporary pigmented precast concrete panels which allow for a versatile but standardised facade showcasing the area's elegant colour palette.

A Design Code will be submitted as part the application with the 'Mandatory' elements being conditioned. This will secure key elements of the design within the approval.

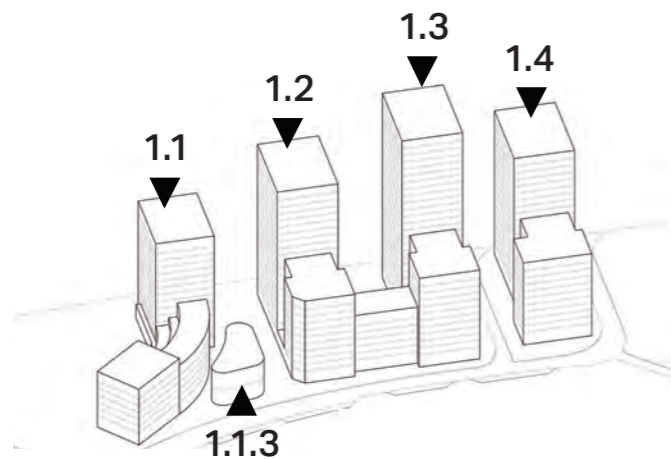

Fig 9.44: Soft pastel tones characterise many regency buildings in North Kensington



Fig 9.45: Regency frontages with definition to plinth



Fig 9.46: Corner of Plot 1.2 facing 'The Avenue' and the site entrance





Fig 9.47: View of Plot 1 showing the pavilion in the foreground



### 9.7.1.3 Material & Detail: Depth & Contrast

The street elevations are organised by a strong facade grid which allows for a simple and clean layering of elements. This grid looks to emphasize the vertical strokes through expressed round pilasters inspired by the area's Neoclassical heritage. Other traditional facade elements such as ledges and cornices are combined with more contemporary shapes to complete a balanced yet distinctive architectural composition.

Soft curves are incorporated to the facade via scalloped window heads which bring dynamism into the grid creating a subtle play of light and shadow.

The importance of a versatile yet regular grid system is evidence by the way the building is able to adapt to different orientations without compromising its architectural integrity.



Fig 9.49: Modular approach to fenestration and balcon design

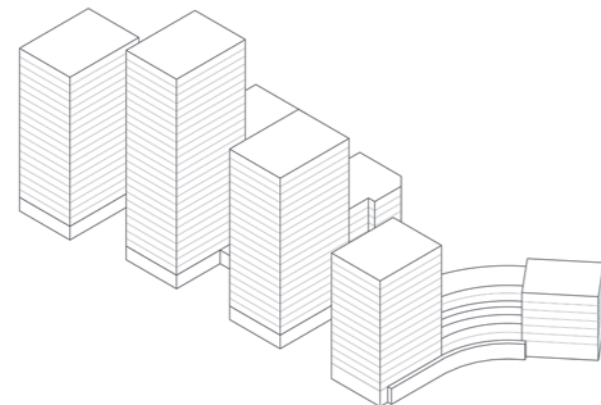

Fig 9.50: Plot 01 Facade Massing



Fig 9.48: Modular approach to elevation and use of simple, refined detailing

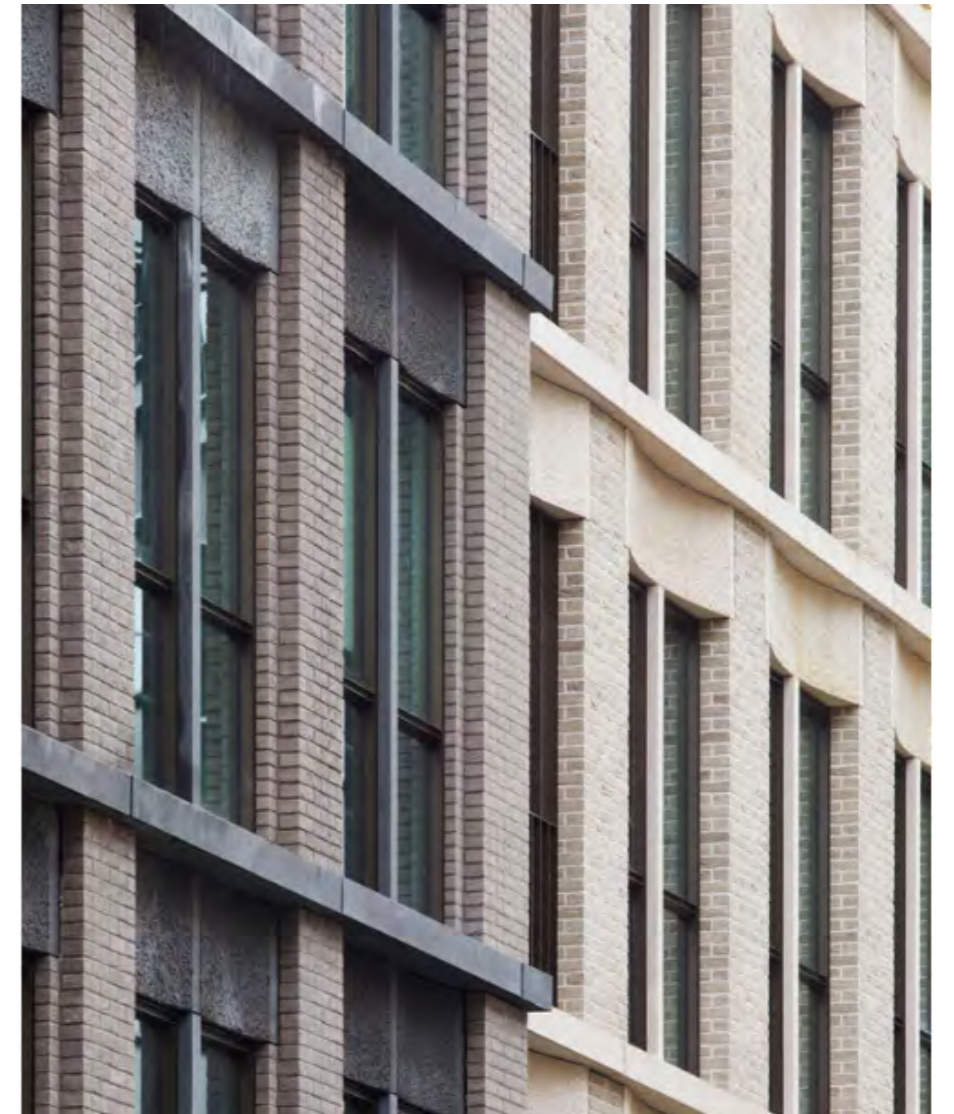

Fig 9.51: Curved and scalloped window heads allow subtle plays of light on facade



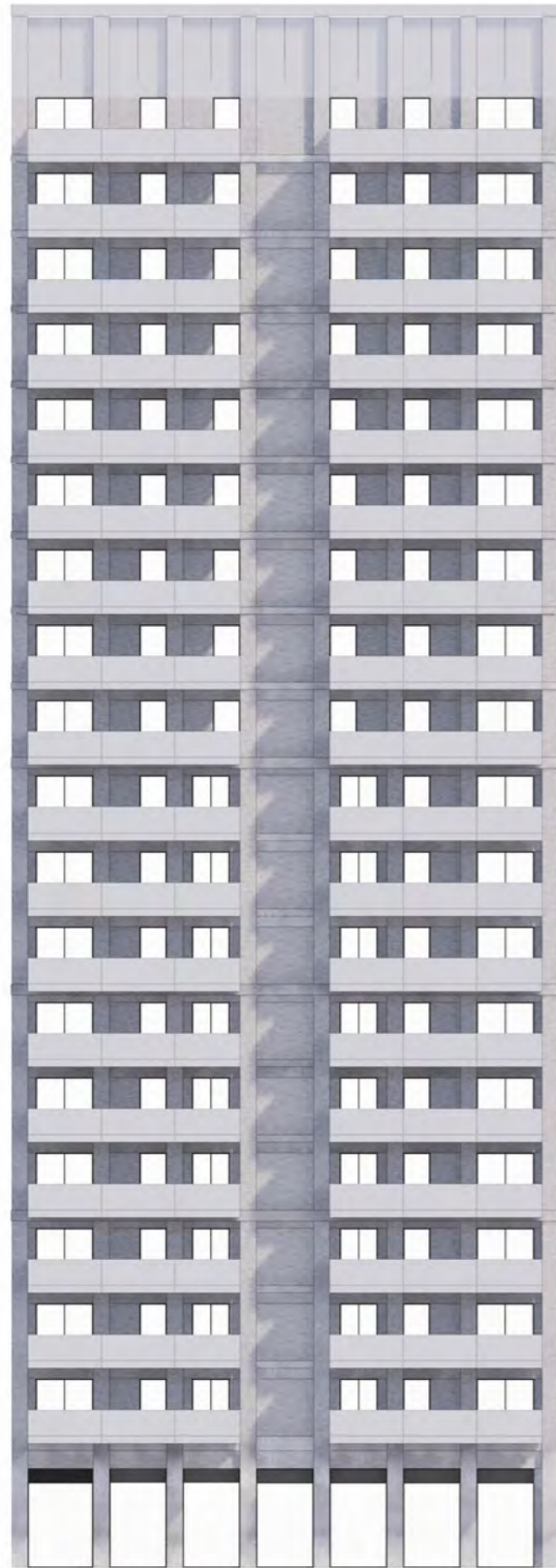

Fig 9.52: South facing elevation showing balcony rhythm



Fig 9.53: Street scene - The Avenue



## 9.7.2 Crescent: Townhouses

The Townhouses facing Maxwell Fry's Kensal House offer a curated balance between architectural heritage and 21st century living. The result is a design language that evokes the grace of its North Kensington counterparts and creates a contextual extension of the surrounding streets.

### 9.7.2.1 Typology & Character

Their design reintroduces the idea of the London townhouse, expressed as a new architectural language as graceful and as resonant of its location as its distinguished antecedent. Cues are taken from the garden square and terraces of West London. Key principles from the era such as basic proportions and layering have been molded and built upon to meet the demands of 21st century Architecture. The result is a clean and sober design which helps to scale down the scheme towards an intimate and carefully landscaped pedestrian street.

The elevation is characterized by the succession of access porches which articulate the private gardens at ground floor. The building offers a series of recessed outdoor gardens on the upper levels.

### 9.7.2.2 Materials & Detailing

In this case the facade follows more subtle ornamentation strategies such as grooves and textures incorporated to the precast panels as patterned reveals.

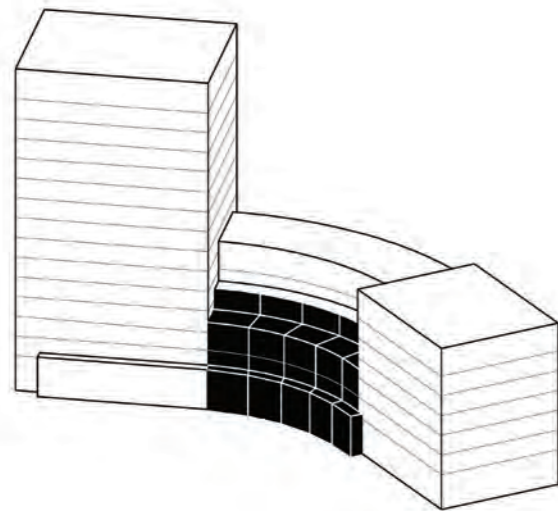

Fig 9.54: Regency townhouses with portico entrance



Fig 9.55: Subtly curved regency facades in North Kensington

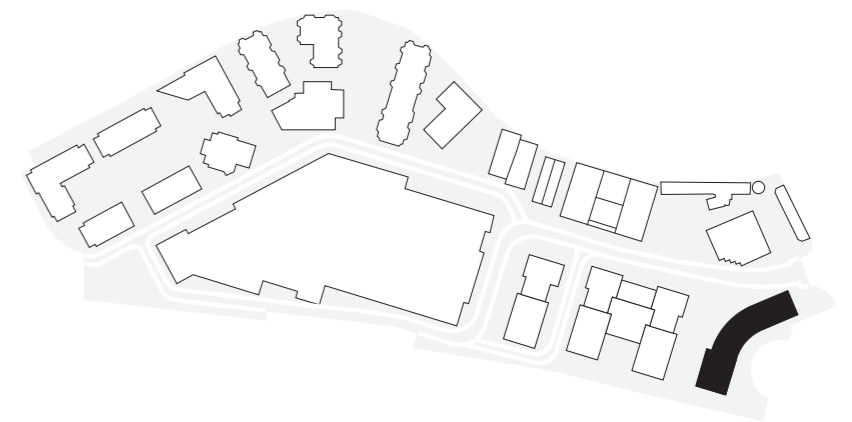

Fig 9.56: Plot 1.1 Location





Fig 9.57: Concept visualisation of the entrance porticos to the Townhouses



Fig 9.58: Townhouse elevation details and materiality



### 9.7.3 Crescent: Gable

Block 1.1 presents an end-of-block elevation towards the East entrance of the site which grants it its gateway character. The scale of the buildings will at this point have reduced to align to the adjacent Grade II\* Listed Kensal House, but will not have lost relevance and meaning.

#### 9.7.3.1 Typology & Character

The end gable of plot 1.1 is again inspired by the classical proportions of base, body and crown, taking precedent from relevant buildings around the area. One of the characteristic features of this typology is the linear balcony along the lower level. This offers both an attractive amenity space at canopy level for the residential levels above, as well as a colonnade covered space towards the street for commercial use.

#### 9.7.3.2 Material & Detail

The gable elevation is framed by the precast concrete panels around the crescent but chooses a warm terracotta brick as means of expressing surface detailing. The different levels are highlighted by a strip of brick soldier course and simple facade openings give structure to the composition. The facade expresses traditional ornamentation through textures and reveals.

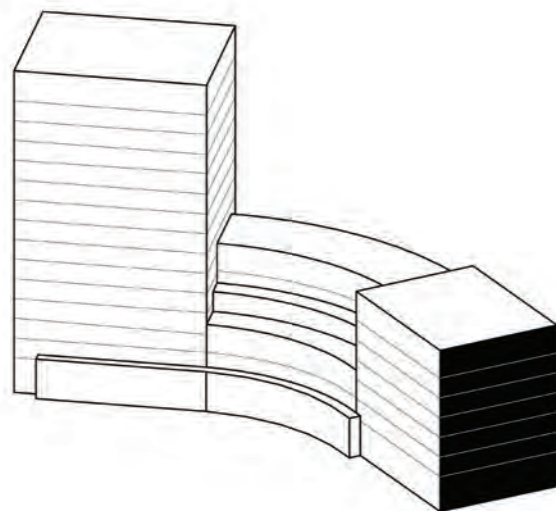
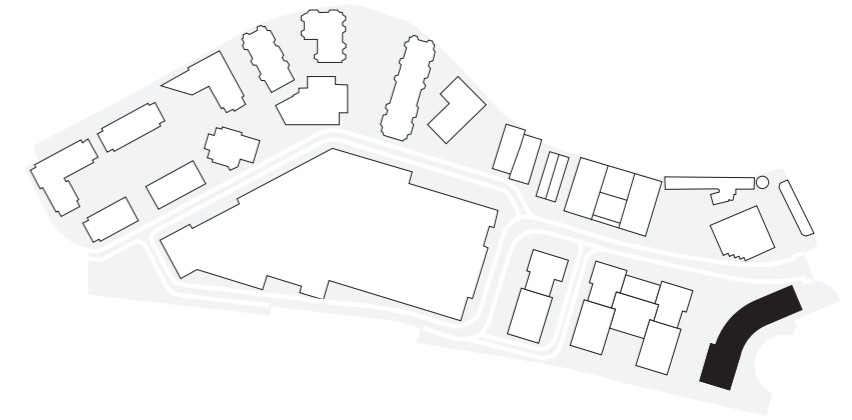





Fig 9.59: Plot 1.1 Key Gable Elevation (illustrative scheme)



### 9.7.4 Crescent: Crown

The uppermost levels of the crescent are stepped back to allow roof terraces and gardens to frame Kensal House adjacent and provide residential amenity space. The stepping of these terraces is an intentional move here to address the lower storey buildings of Kensal House. This gesture will in turn allow more natural light into the adjacent buildings.

It is intended that the terraces would act as roof gardens for the townhouses beneath whilst the upper most levels would provide communal gardens for other residents of the Plot to access. The angle of the terraces allows natural light to flood into the dwelling here, particularly in the morning and midday, due to the orientation of the Plot.

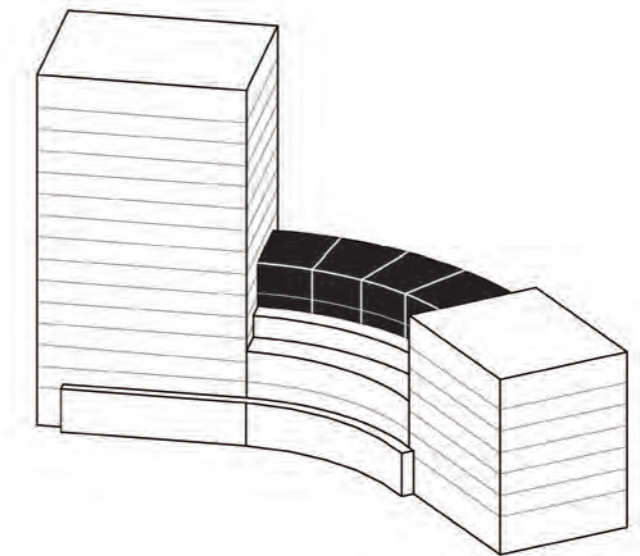
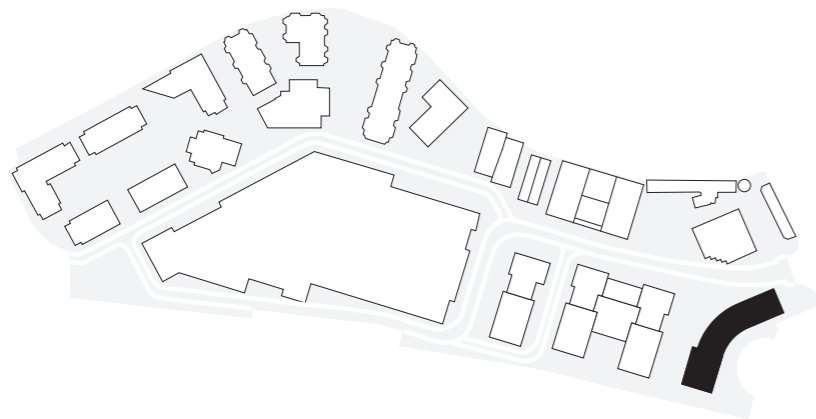





Fig 9.60: Plot 1.1 Roof Terraces





## 9.7.5 Pavilion: The Local Bistro

The idea of a pavilion servicing the area as a satellite building housing a cafe/restaurant/bar will enrich the experience at ground level and diversify the masterplan's public realm. The building will complement both the residential and flexible workspace allowance as well as provide a street marker for visitors.

### 9.7.5.1 Typology & Character

The building emerges as a reinterpretation of a victorian steel frame pavilion and a celebration of the areas industrial heritage. Its key location between buildings 1.1 and 1.2 offers a break-out area near the entrance of the site and invites visitors into the pedestrian commercial street. Its curved footprint pairs with the soft corners of the adjacent blocks, acting as a street marker.

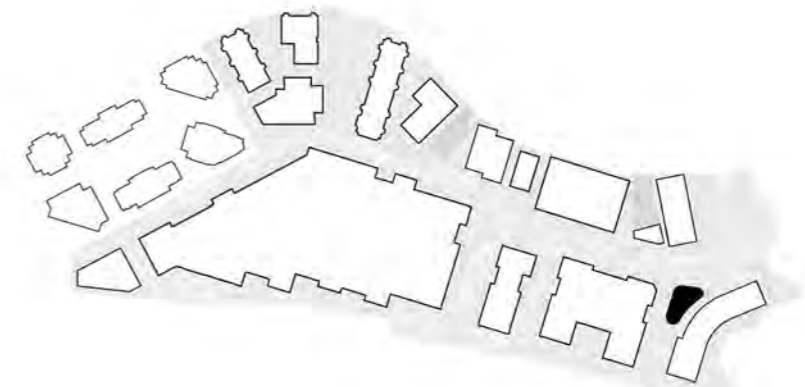





Fig 9.61: Plot 1 Pavilion - Illustrative Scheme

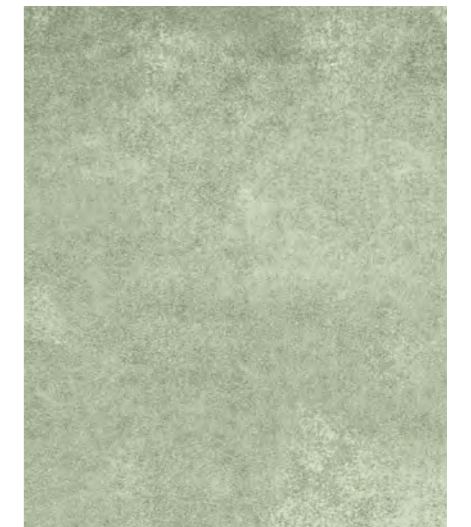

Fig 9.62: Plot 1 Pavilion - CGI of High Street facing elevation



Fig 9.63: Plot 1 Pavilion - material palette



# 9.8 Sustainability

## 9.8.1 Overview

The Sustainability Strategy has been produced by Hoare Lea in conjunction with the design team. Hoare Lea have produced a Sustainability Statement, Energy Strategy, as well as carrying out Thermal Comfort Assessments and preparing BREEAM Pre-Assessments for the relevant building uses within the proposals.

The following national and local policies and guidance have informed the proposals: the National Planning Policy Framework, London Plan Guidance on Circular Economy and Whole Life Carbon, Building Regulations Part L, the Greater London Authority (GLA) London Plan (2021), the London supplementary planning guidance (SPG) on Sustainable Design and Construction (2014), and the current Royal Borough of Kensington and Chelsea Local Plan (2019).

The strategy is to be read in conjunction with the architectural drawings. Any recommendations within the reports are subject to discussion and approval by the Statutory Authorities. Full details can be found within these reports which accompany this application. The following page highlights the key design moves and technologies proposed across the masterplan.

Sustainability is at the heart of the design for Plot 1 and our proposals seek to address all aspects of environmental, social, and cultural sustainability. Its design aims to protect and enhance the site's ecology and biodiversity while using the site effectively and creating an environment that will nurture and support the community.

South Terrace, green roofs and the lower podium roofs are all designed to enhance ecology and biodiversity and provide opportunities for play for children of all ages.

We have designed the buildings to last for a long time and age gracefully, prioritising long-lasting quality materials with low environmental impact, and to minimise air, noise, light, and water pollution. All external envelopes will be composed of non-combustible materials. The principles of circular economy will be used throughout design, construction, and end of life.

The design aims to optimise the health and wellbeing of residents with good levels of internal daylight, thermal comfort, safety, and security. A high proportion of dual aspect dwellings ensures good access to daylight and natural ventilation. The design promotes active travel, with new pedestrian links and cycle storage facilities in line with local policy.

In addition to new homes, the site will provide a variety of new green spaces and attractive public realm. The plot also provides the potential for affordable workspace to ensure a diverse range of opportunities exist for all users. These new commercial units would provide low cost and energy efficient premises for tenants.



Fig 9.64: Plot 01 view west along the Avenue





Fig 9.65: Plot 01 Sustainability Principles







# 10.0 Illustrative Proposals - Plot 5

<b>10.1</b>	<b>Design Summary and Explanation</b>	<b>305</b>
10.1.1	Plot 05 Context & Analysis	305
10.1.2	Plot 05 Narrative	306
<b>10.2</b>	<b>Layout</b>	<b>309</b>
10.2.1	Layout Overview	309
<b>10.3</b>	<b>Height and Massing</b>	<b>315</b>
10.3.1	Massing & Proportions	315
<b>10.4</b>	<b>Use</b>	<b>317</b>
10.4.1	Commercial	317
10.4.2	Residential	319
<b>10.5</b>	<b>Amount</b>	<b>321</b>
10.5.1	Heights & Capacity	321
<b>10.6</b>	<b>Appearance</b>	<b>322</b>
10.6.1	Typology & Character	322
10.6.2	Typology & Character	323
10.6.3	Material & Composition	324
10.6.4	Pavilion	326
<b>10.7</b>	<b>Sustainability</b>	<b>327</b>







## **Bounding the northern edge of The Avenue and fronting the Grand Union Canal, Plot 05 occupies a prime position within the new neighbourhood centre.**

In contrast with the regency architecture that inspires other buildings across the masterplan, the character of Plot 05 is marked by the industrial nature of historical wharf buildings. Grand Union Canal offers a unique landmark on which to base the architectural principles that shape these buildings, allowing it to integrate and have a familiarity with its context.

Its location and design make it an ideal location for cafes and restaurants facing out onto the two basins which flank the east and west facades of the plot. Its southern flanks could house retail uses facing onto The Avenue, serving to create a lively and vibrant high street. In contrast, the northern aspect creates a perfect location for residential amenity spaces to enjoy the serenity of the canal and cemetery beyond.



# 10.1 Design Summary and Explanation

## 10.1.1 Plot 05 Context & Analysis

Plot 05 sits to the north of the masterplan. It occupies a prominent edge that fronts onto the existing canal and sits opposite the listed Kensal Green Cemetery. This gives Plot 05 the opportunity to play a major role in enhancing the existing public realm.

### 10.1.1.1 Plot Boundaries & Constraints

The primary physical constraint to the Plot 05 site is the Grand Union Canal which spans along the northern edge of the masterplan. With a tight footprint due to various constraints around the plot, the buildings will be located in close proximity to the canal, which will offer the opportunity for a new urban fabric to stitch together with the existing towpath.

The northern edge of the plot is determined by the existing canal towpath and the Grand Union Canal itself.

To the east and west, the plot is bookended by two existing basin inlets. These inlets are remnants from the sites previous heritage and are proposed to be developed into water based public amenity for the wider masterplan also offer visual connections back to the canal and the cemetery beyond.

The southern edge of the plot is bound by The Avenue which contains the principle road network and new neighbourhood centre.

### 10.1.1.2 Role in Masterplan

Occupying the Northern edge of the masterplan, Plot 05 establishes itself as a key moment both within a prominent commercial front to the canal edge and also southward into the proposed central street, known as The Avenue. Glazed, arched frontages in the illustrative scheme act to invite people to interact with the plot and enhance the vibrancy of the high street.

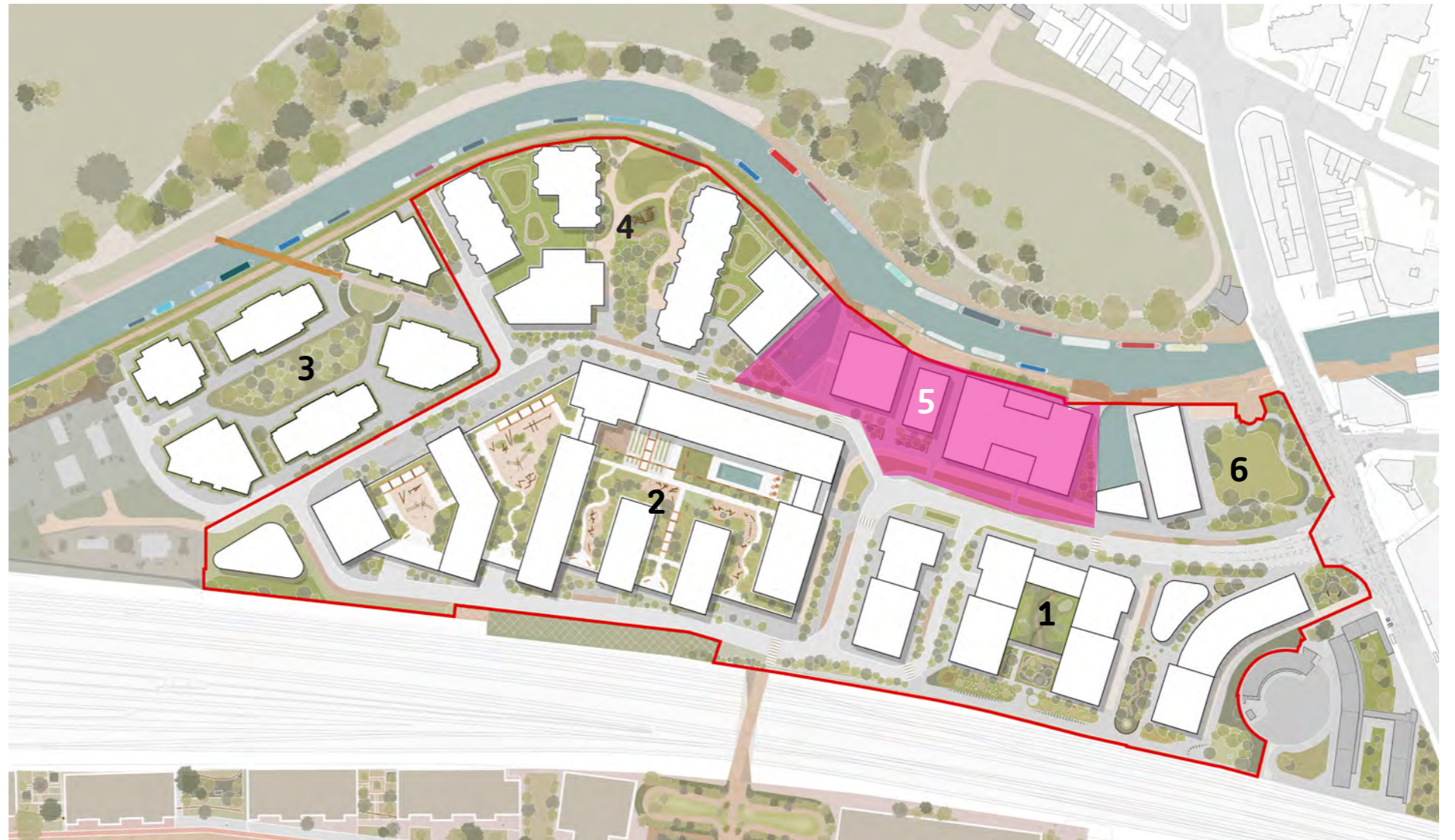

Fig 10.1: Plot 05 Extents

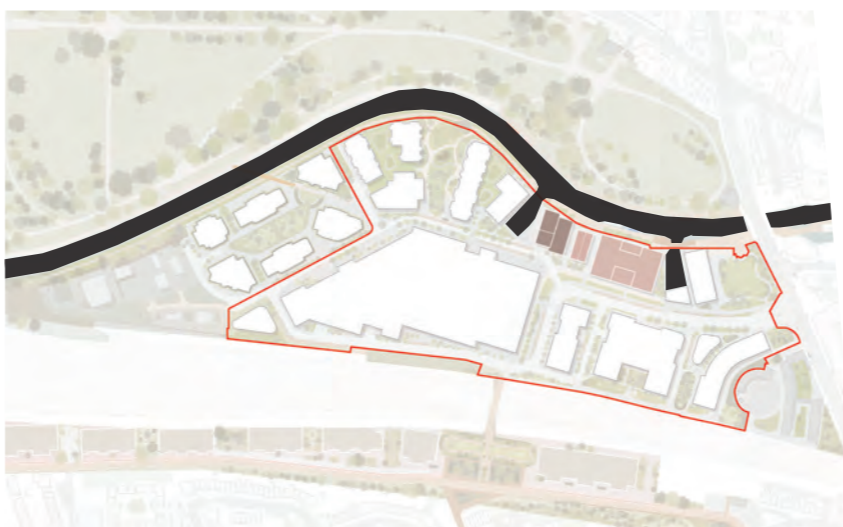

Fig 10.3: Constraints - Proximity to Canal



Fig 10.2: Constraints - Proximity to existing basin and The Avenue



## 10.1.2 Plot 05 Narrative

The plot draws influence from the industrial heritage of the site, with Plot 5.2 and 5.3 as a reference to a warehouse typology still visible along sections of the Grand Union Canal. Plot 5.1 acts as a lower scale marker building, its additional height giving it presence on the canal edge, and signally the reinstated basin. The buildings are intentionally massed and positioned in this location to reference the historic building positions on site and referencing its former use. Finally, Plot 5.4 is a pavilion building and acts as a human scale mediator between the larger buildings which it abuts. Its scale is purposeful, acting to draw pedestrians from the canal edge into the heart of the masterplan. Its architecture is derived from the smaller scale industrial buildings on site (shown in figure 10.16) and its arched frontages are a direct link to these buildings.

Balconies have been placed on all facades across the Plot. These provide private amenity space for the residents whilst capitalising on the views across the canal and towards the cemetery beyond.

The roof terrace of the plot provides a biodiverse habitat and private amenity space for all residents. It is accessed from the stair and lift cores within plot 5.2 and 5.3.

### 10.1.2.1 Wharf Experience

Outlining the Canal, Plot 05 offers a unique moment along the towpath incorporating a new public realm design and providing active frontages against the waterfront. Carefully landscaped seating areas will define the threshold between an active ground floor and the serenity of the Canal. Kensal Green Cemetery acts as a historical backdrop to the plot, creating an enriching experience when viewed across the water.



Fig 10.6: Plot 05 illustrative proposal with Plot 5.2-5.3 in the foreground, and Plot 5.1 marker building in the background. 6



Fig 10.4: Plot 05 relationship with the canal and opportunities for play



Fig 10.5: Activity and building frontages facing towpath